

Linear Bushings and Shafts

STAR – Linear Motion Technology

Ball Rail® Systems

Standard Ball Rail® Systems
Ball Rail® Systems with Aluminum Runner Blocks
Super Ball Rail® Systems
Wide Ball Rail® Systems
Miniature Ball Rail® Systems
Cam Roller Guides
Accessories

Roller Rail Systems

Linear Bushings and Shafts

Linear Bushings
Linear Sets
Shafts
Shaft Support Rails
Shaft Support Blocks
Ball Transfer Units

Screw Drives

Precision Ball Screw Assemblies
End Bearings and Housings

Linear Motion Systems

Linear Motion Slides
Linear Modules
Compact Modules
Ball Rail Tables
Super Structure™
Controllers, Motors, Electrical Accessories
Linear Actuators

Rexroth Star GmbH
D-97419 Schweinfurt















REG. No.
1617 - 03



STAR, Ball Rail and  are trademarks registered for Rexroth Star GmbH, Germany.

Roller Rail is a trademark of Rexroth Star GmbH, Germany.

Linear Bushings and Shafts

Product Overview	4	
General Technical Data and Mounting Instructions	12	
Standard Linear Bushings	26	
Linear Sets with Standard Linear Bushings	40	
Super Linear Bushings A and B	50	
Linear Sets with Super Linear Bushings A and B	66	
Super Linear Bushings H and SH	88	
Linear Sets with Super Linear Bushings H and SH	104	
Compact Linear Bushings	112	
Compact Linear Sets	118	
Segmental Linear Bushings	120	
Linear Sets with Segmental Linear Bushings	126	
Radial Linear Bushings	128	
Linear Sets with Radial Linear Bushings	136	
Radial Compact Sets	140	
Torque-Resistant Linear Bushings	146	
Torque-Resistant Compact Linear Bushings	154	
Linear Sets with Torque-Resistant Linear Bushings	156	
Linear Bushings for Combined Linear and Rotary Motion	174	
Precision Steel Shafts	178	
Shaft Support Rails	198	
Shaft Support Blocks	224	



STAR Linear Bushing,
STAR Super Linear Bushing,
STAR Radial Linear Bushing,











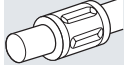
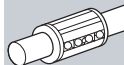

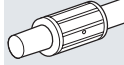
STAR Linear Set and
STAR Radial Set

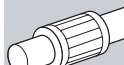

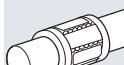

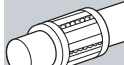

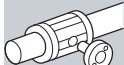
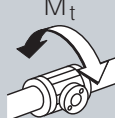

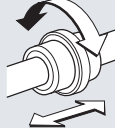







are trade marks registered for
Rexroth Star GmbH, Germany.

STAR – Linear Bushings and Shafts

Product Overview

Linear Bushings

		Page	Special features	Types	
	Standard 0600-... to 0632-...	26		<ul style="list-style-type: none"> - closed/adjustable/open - without/with internal wiper seals - STAR Resist (zinc-iron coating) 	
	Super ^A 0670-... to 0671-... Super-^E 0672-... to 0673-...	50	 ≤ 30' (Version ^A only)	<ul style="list-style-type: none"> - closed/open - with internal wiper seals/ separate seals 	
	Super ^H 0732-... to 0733-...	88	 ≤ 30'	<ul style="list-style-type: none"> - closed/open - without/with internal wiper seals/fully sealed - STAR Resist (zinc-iron coating) 	
	Super ^{SF} 0730-... to 0731-...	88	 ≤ 30'	<ul style="list-style-type: none"> - closed/open - without/with internal wiper seals/fully sealed - STAR Resist (zinc-iron coating) 	
	Compact 0658-...	112		<ul style="list-style-type: none"> - internal/separate wiper seals - normal/ corrosion-resistant - STAR Resist (zinc-iron coating) 	
	Segmental 0668-...	120		<ul style="list-style-type: none"> - normal/ corrosion-resistant 	
	Radial 0678-...	128		<ul style="list-style-type: none"> - without seals/fully sealed 	
Torque-Resistant Linear Bushings		Torque-Resistant and Torque-Resistant Compact 0696-... to 0720-...	146	 M _t	<ul style="list-style-type: none"> - one/two ball tracks
Linear Bushings for Combined Linear and Rotary Motion		Linear and Rotary Motion 0663-... to 0667-...	174		<ul style="list-style-type: none"> - deep groove ball bearing - needle roller bearing









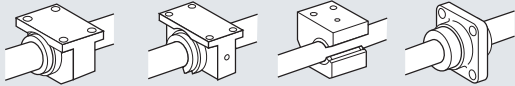
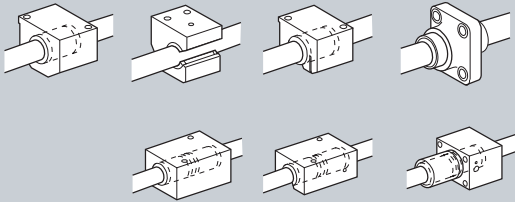
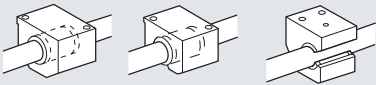
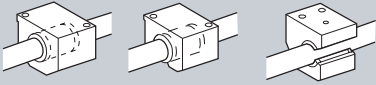
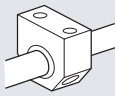
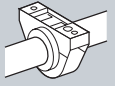
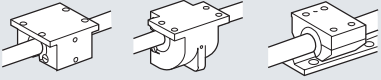
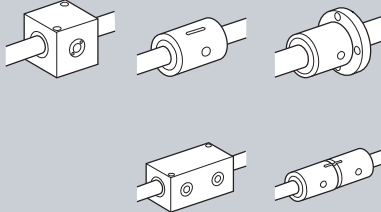







		Shaft diameter (mm)											
		5	8	10	12	16	20	25	30	40	50	60	80
		Dynamic load capacity C (N)											
		180	320		420	580	1170	2080	2820	5170	8260	11500	21000
					430	600	1280	2270	2890	5280	8470	11800	21500
				550	770	940	1860	3640	4420	7590	11100		
					880	1060	1880	3680	4470	7680	11200		
							2520	4430	6300	9680	16000	23500	
							2520	4430	6300	9680	16000	23500	
							3530	6190	8800	13500	22300		
							3530	6190	8800	13500	22300		
					730	950	1120	2330	3060	5040	5680		
					510	660	780	1630	2140	3520	3970		
					480	720	1020	1630	2390	3870			
					240	360	510	820	1200	1940			
									8500	13900	20800	29500	54800
					640	780	1550	3030	3680	6320	9250		
		180	320		480	720	1020	1630	2390	3870	8260	11500	21000
		180	320		420	580	1170	2080	2820	5170	8260	11500	21000

STAR – Linear Bushings and Shafts

Product Overview

Linear Sets



Designs		Page	Types	
	1065-... to 1081-... with Standard Linear Bushings	40	<ul style="list-style-type: none"> - closed/open - adjustable/ not adjustable - with side opening - with flange 	
	1032-... to 1087-... with Super A Linear Bushings and Super B Linear Bushings	66	<ul style="list-style-type: none"> - cast iron/aluminum - closed/open - adjustable/ not adjustable - with side opening - with flange - tandem (aluminum only) 	
	1701-... to 1706-... with Super C Linear Bushings	104	<ul style="list-style-type: none"> - closed/open - with side opening - adjustable/ not adjustable 	
	1701-... to 1706-... with Super S Linear Bushings	104	<ul style="list-style-type: none"> - closed/open - with side opening - adjustable/ not adjustable 	
	1027-... to 1028-... with Compact Linear Bushings	118	<ul style="list-style-type: none"> - adjustable/ not adjustable - normal/ corrosion-resistant 	
	1060-... with Segmental Linear Bushings	126	<ul style="list-style-type: none"> - normal/ corrosion-resistant 	
	1075-... to 1078-..., 1611-... to 1613-... with Radial Linear Bushings	136	<ul style="list-style-type: none"> - adjustable/ not adjustable - with side opening - Radial Compact Sets 	
	0721-... to 1099-... with Torque-Resistant Linear Bushings	156	<ul style="list-style-type: none"> - one/two ball tracks - single/tandem - steel/aluminum - housing/sleeve - sleeve with flange 	

		Shaft diameter (mm)										
		8	10	12	16	20	25	30	40	50	60	80
		Dynamic load capacity C (N)										
		320		420	580	1170	2080	2820	5170	8260	11500	21000
						1280	2270	2890	5280	8470	11800	21500
			550	770	940	1860	3640	4420	7590	11100		
				880	1060	1880	3680	4470	7680	11200		
			890	1250	1530	3020	5910	7180	12300	18000		
				1430	1720	3050	5980	7260	12500	18200		
						2520	4430	6300	9680	16000	23500	
						2520	4430	6300	9680	16000	23500	
						3530	6190	8800	13500	22300		
						3530	6190	8800	13500	22300		
				730	950	1120	2330	3060	5040	5680		
				510	660	780	1630	2140	3520	3970		
				480	720	1020	1630	2390	3870			
				240	360	510	820	1200	1940			
								8500	13900	20800	29500	54800
				640	780	1550	3030	3680	6320	9250		
				1040	1260	2500	4900	6000	10200	15000		





STAR – Linear Bushings and Shafts

Product Overview

Precision Steel Shafts

Designs		Page	Types/Special features
	1000-...	194	Solid shaft
			- heat-treatable steel
			- corrosion-resistant X46Cr13
			X90CrMoV18
			- STAR Resist (zinc-iron coating)
- hard chrome plated			
	1001-...	196	Tubular shaft
			- heat-treatable steel
- hard chrome plated			

Shaft Support Blocks

Designs		Page	Types/Special features
	1055-...	226	- cast iron
	1057-...	228	- aluminum - also for ALU-STAR Profile Systems
	1056-...	230	- flange - cast iron
	1058-...	232	- aluminum - for Compact Linear Sets





	Linear bushing diameters	Shaft diameter (mm)																									
		5	8	10	12	14	15	16	18	19	20	22	24	25	30	32	35	38	40	45	50	55	60	70	80	100	110
	Other diameters	6																									
		•	•	•	•	•	•	•	•	•	•	•	•	•	•	•	•	•	•	•	•	•	•	•	•	•	•
		•	•	•	•	•		•		•			•	•					•		•		•		•		
					•			•		•			•	•					•		•		•		•		
		•		•	•	•		•		•			•	•					•		•						
					•			•		•			•	•					•		•		•		•		
													•	•					•		•		•		•		
													•	•					•		•		•		•		
													•	•					•		•		•		•		
													•	•					•		•		•		•		

		Shaft diameter (mm)											
		5	8	10	12	16	20	25	30	40	50	60	80
		Available											
			•		•	•	•	•	•	•	•	•	•
				•	•	•	•	•	•	•	•	•	
					•	•	•	•	•	•	•		
					•	•	•	•	•	•	•		

STAR – Linear Bushings and Shafts

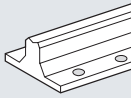
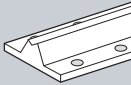
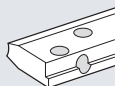
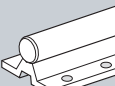
Product Overview

Shaft Support Rails

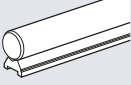
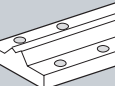
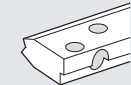
Designs	Page	Types/Special features
 1050-...	204	for open-type Standard and Super Linear Bushings - with flange - high-profile
 1050-...	206	for open-type Standard and Super Linear Bushings - with flange - low-profile
 1054-...	208	for open-type Standard and Super Linear Bushings - for side installation - with fitting edge
 1010-...	210	for open-type Standard and Super Linear Bushings - with flange - available only with shaft - low-profile
 1025-...	212	for open-type Standard and Super Linear Bushings - for ALU-STAR Profile Systems - available only with shaft
 1013-...	214	for open-type Standard and Super Linear Bushings - without flange - available only with shaft - aluminum
 1016-...	216	for open-type Standard and Super Linear Bushings - without flange - available only with shaft - with fitting edge - steel
 1052-...	218	for Radial Linear Bushings - with flange - with fitting edge
 1053-...	220	for Radial Linear Bushings - for side installation - with fitting edge
 1012-...	222	for Radial Compact Sets - with flange - with fitting edge - available only with shaft

All Shaft Support Rails are also available with the shaft ready-mounted.

		Shaft diameters (mm)											
		5	8	10	12	16	20	25	30	40	50	60	80
		Available											
					•	•	•	•	•	•	•	•	•
					•	•	•	•	•	•	•	•	•
							•	•	•	•	•		
						•	•	•	•	•			
							•	•	•				
					•	•	•	•	•				
						•	•	•	•	•			
									•	•	•	•	•
									•	•	•	•	•
									•	•	•	•	•

General Technical Data and Mounting Instructions

Comparison of the various types of Linear Bushings

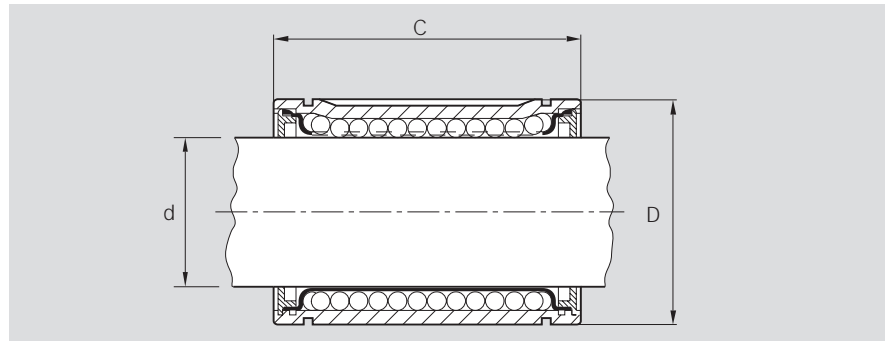

Main dimensions

Size (mm)	Standard Linear Bushings		Super Linear Bushings				Compact Linear Bushings		Segmental Linear Bushings		Radial Linear Bushings	
	Dimensions (mm)		Dimensions (mm)				Dimensions (mm)		Dimensions (mm)		Dimensions (mm)	
Ø d	D	C	A, B		H, SH		D	C	D	C	D	C
5	12	22	-	-	-	-	-	-	-	-	-	-
8	16	25	-	-	-	-	-	-	-	-	-	-
10	-	-	19	29	-	-	-	-	-	-	-	-
12	22	32	22	32	-	-	19	28	20	24	-	-
16	26	36	26	36	-	-	24	30	25	28	-	-
20	32	45	32	45	32	45	28	30	30	30	-	-
25	40	58	40	58	40	58	35	40	37	37	-	-
30	47	68	47	68	47	68	40	50	44	44	60	75
40	62	80	62	80	62	80	52	60	56	56	75	100
50	75	100	75	100	75	100	62	70	-	-	90	125
60	90	125	-	-	90	125	-	-	-	-	110	150
80	120	165	-	-	-	-	-	-	-	-	145	200

ISO 10285 Linear ball bearings, metric series

This standard contains the main dimensions, tolerances and definitions for linear ball bearings. It subdivides the Linear Bushings into dimension series and tolerance classes. The following table provides an overview of the series and tolerance classes to which the Linear Bushings correspond.

Series	Tolerance class	Standard Linear Bushings		Super Linear Bushings A, B, H, SH	Compact Linear Bushings ¹⁾	Segmental Linear Bushings	Radial Linear Bushings
		closed	adjustable, open				
1	L9						
2							
3	L7						
	L7A						
	L6A						
4	L6M						

¹⁾ The "Compact RT" type deviates slightly in working bore diameter from the standard.

Load capacity and direction of load

If the direction of load and the position of the linear bushings cannot be precisely defined, calculations must be based on the minimum load capacity rating.

These ratings are given in the tables for closed-type linear bushings. The exceptions are Super Linear Bushings **HA** and **SB**, which can be retained in position even in the closed type, thus allowing the load to be held in the "max" position relative to the direction of load.

Open-type linear bushings always require retention. The load capacity rating then applies to the main direction of load acting perpendicular to the opening.

As a general rule, if the direction of load is exactly known, the load capacity rating can be multiplied by the factor f_{max} or f_{0max} .

These factors are indicated for each type of linear bushing.

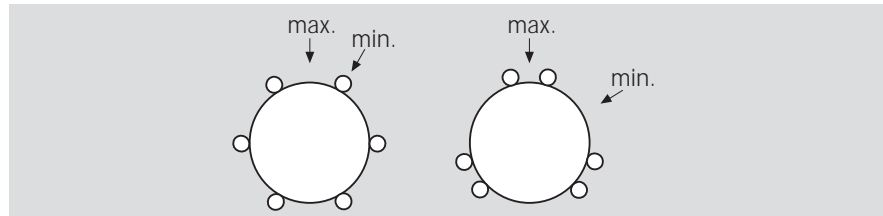

The load capacity ratings have been calculated on the basis of DIN 636 Part 1, in which the following definitions and calculation principles may be found.

The **static load C_0** is that radial static load applied to the assembly that causes permanent deformation of $0.0001 \times$ the ball diameter at the most highly loaded point of contact between the balls and the ball track. Care must be taken to ensure that this maximum load intensity is not exceeded even during load peaks (severe shock loads).

The relationship between the **dynamic load capacity C** , the resultant load and the travel life are defined in DIN 636 Part 1. Data on the dynamic load ratings are therefore based on the nominal life.

Dynamic load capacities

Size (mm) $\varnothing d$	Standard Linear Bushings Load capacity (N) C	Super Linear Bushings HA , EB H ¹⁾ SB ¹⁾ Load capacity (N)			Compact Linear Bushings Load capacity (N) C	Segmental Linear Bushings Load capacity (N) C	Radial Linear Bushings Load capacity (N) C
		C	C	C			
5	180	–	–	–	–	–	
8	320	–	–	–	–	–	
10	–	550	–	–	–	–	
12	420	770	–	–	730	480	
16	580	940	–	–	950	720	
20	1170	1860	2520	3530	1120	1020	
25	2080	3640	4430	6190	2330	1630	
30	2820	4420	6300	8800	3060	2390	
40	5170	7590	9680	13500	5040	3870	
50	8260	11100	16000	22300	5680	–	
60	11500	–	23500	–	–	–	
80	21000	–	–	–	–	–	

¹⁾ The load capacity figures given here are maximum values as position and direction of load can be precisely defined.

Note on dynamic load capacities:

The figures for dynamic load capacities have been calculated assuming a nominal travel life of 100,000 meters. For a travel life of 50,000 meters, the 'C' figures in the table must be multiplied by a factor of 1.26.

General Technical Data and Mounting Instructions

Nominal Life

Calculation

The travel life expectancy is largely determined by the quality and hardness of the shaft used.



Precision Steel Shafts are induction-hardened and ground, thus ensuring that Linear Bushings will give a long travel life.

Definition to DIN 636, Part 1

"The theoretical life which is reached to 90% or over by one single bearing or a group of obviously identical bearings running under identical conditions, made of materials and in the quality generally specified today and under normal operating conditions."

The figures for dynamic load capacities have been calculated assuming a nominal travel life of 100,000 meters. For a travel life of 50,000 meters, the 'C' figures in the table must be multiplied by a factor of 1.26.

Certain Linear Bushing models deviate from the dynamic load capacities specified by DIN 636. These are:

Super Linear Bushing 	+25 %
Super Linear Bushing 	+20 %
Super Linear Bushing 	+15 %
Compact Linear Bushing	+15 %
Radial Linear Bushing	+10 %
Segmental Linear Bushing	-25 %

No DIN calculations have been performed for corrosion-resistant models.

The formula for the calculation of travel life for a known shaft hardness and operating temperatures in excess of 100 °C is as follows:

$L = \left(\frac{C}{F} \cdot f_H \cdot f_t \right)^3 \cdot 10^5$	L = nominal travel life (m) C = dynamic load capacity (N) F = resultant of external forces acting on the linear bushing (N) f _H = shaft hardness factor f _t = temperature factor
$L_h = \frac{L}{2 \cdot s \cdot n \cdot 60}$	L _h = nominal rated life (h) s = stroke length (m) n = stroke repetition rate (full cycle) (min ⁻¹)

Shaft hardness factor

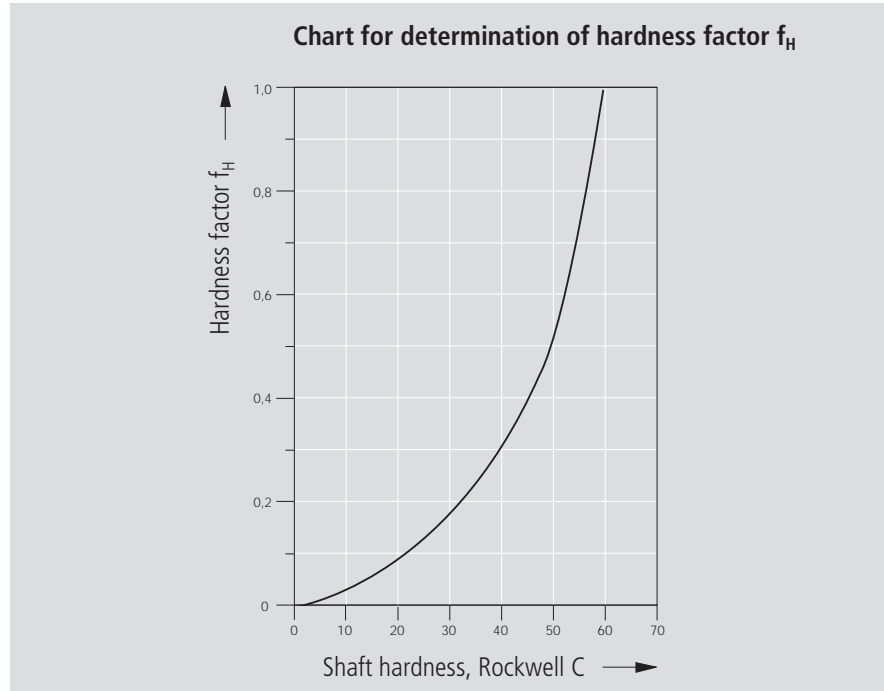

Bushing temperature factor

Bushing temperature °C	100	125	150	175	200
Temperature factor f_t	1	0.92	0.85	0.77	0.70

General Technical Data and Mounting Instructions

Load capacity calculation

The following formula can be used in design calculations:

$$C = \frac{F}{f_H \cdot f_t \cdot f_L}$$

C = dynamic load capacity (N)
 F = resultant of external forces acting on the linear bushing (N)
 f_H = shaft hardness factor
 f_t = temperature factor
 f_L = travel life factor

Travel life factor

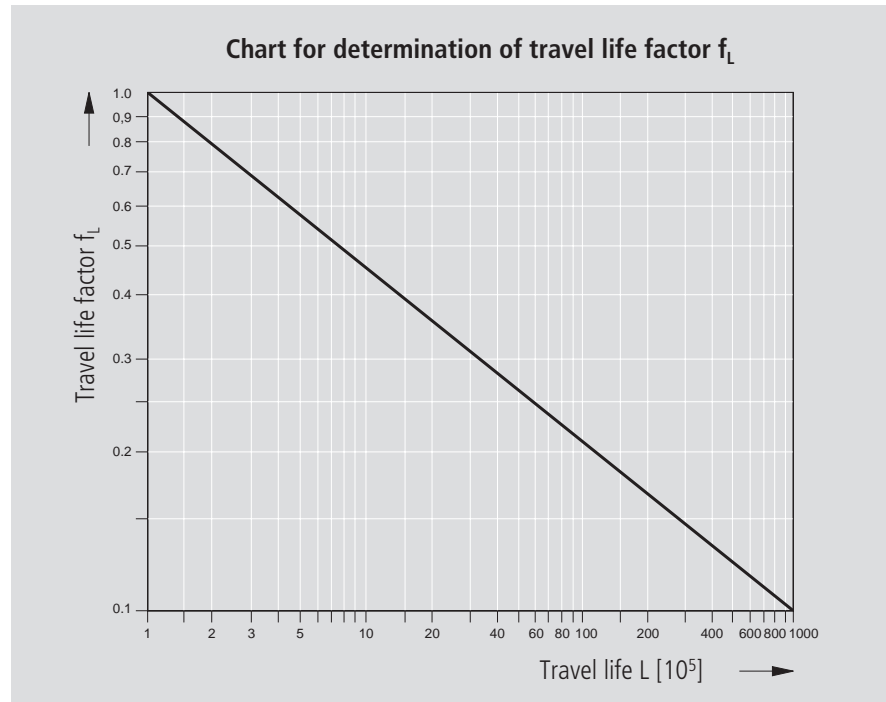

Short stroke

In short-stroke applications, the service life of the shafts is shorter than that of the Segmental, Compact and Super Linear Bushings (refer also to the "Technical Data" section for the individual Linear Bushings).

Variable loads

If the bushings are subjected to variable loads but constant direction of load, the equivalent dynamic load F may be calculated as follows:

$$F = \sqrt[3]{F_1^3 \cdot \frac{q_1}{100} + F_2^3 \cdot \frac{q_2}{100} + \dots + F_n^3 \cdot \frac{q_n}{100}}$$

F = dynamic load (N)
 $F_1, F_2 \dots F_n$ = discrete dynamic load steps (N)
 $q_1, q_2 \dots q_n$ = percentage of stroke covered under $F_1, F_2 \dots F_n$ (%)

If the load acts from several directions, the overall load resultant must be calculated.

Major preloads also tend to shorten the travel life, and allowance should be made accordingly.

Calculation example

The load on a slide acting perpendicular to the twin shafts is 800 N. It is assumed that the load is distributed evenly over the four linear bushings. The slide reciprocates through a stroke of $s = 0.05$ m at a frequency of $n = 300$ complete cycles per minute. The minimum service life is $L_h = 2500$ hours. The operating temperature is less than 100 °C. Precision Steel Shafts of hardness Rockwell C 60 or better and Standard Linear Bushings are to be used.

Determination of linear bushing size required

Load per linear bushing:

$$F = \frac{800}{4} = 200 \text{ N}$$

Travel life L as total linear movement in meters:

$$L = 2 \cdot s \cdot n \cdot 60 \cdot L_h \text{ (m)}$$

$$L = 2 \cdot 0.05 \cdot 300 \cdot 60 \cdot 2500 \text{ (m)}$$

$$L = 45 \cdot 10^5 \text{ m}$$

The travel life factor f_L associated with the desired travel life of 45×10^5 m can be read from the chart as $f_L = 0.28$.

The hardness chart gives a hardness factor of $f_H = 1$ for a shaft hardness of Rockwell C 60. The temperature factor as given in the table is $f_t = 1$.

With these input data, the required dynamic load capacity C can be calculated as follows:

$$C = \frac{F}{f_H \cdot f_t \cdot f_L} = \frac{200}{1 \cdot 1 \cdot 0.28} = 714 \text{ N}$$

The linear bushing with the next higher dynamic load capacity should be used, i.e. STAR Standard Linear Bushing 0610-020-00, which has a dynamic load capacity $C = 1170$ N and a static load capacity $C_o = 860$ N.

Calculation of travel life expectancy

The travel life expectancy in meters of the selected linear bushing 0610-020-00 can now be calculated by introducing the following values into the formula

$$L = \left(\frac{C}{F} \cdot f_H \cdot f_t \right)^3 \cdot 10^5 \text{ (m)}$$

dynamic load capacity $C = 1170$ N

load on each linear bushing $F = 200$ N

hardness factor $f_H = 1$

temperature factor $f_t = 1$

Travel life $L = \left(\frac{1170}{200} \cdot 1 \cdot 1 \right)^3 \cdot 10^5 \text{ (m)}$

$$L = 200 \cdot 10^5 \text{ m}$$

The service life in hours can now be calculated from the travel life in meters with the aid of the formula:

$$L_h = \frac{L}{2 \cdot s \cdot n \cdot 60}$$

$$L_h = \frac{200 \cdot 10^5}{2 \cdot 0.05 \cdot 300 \cdot 60}$$

$$L_h = 11122 \text{ hours}$$

General Technical Data and Mounting Instructions

Lubrication

Standard lubrication practices as applied for anti-friction bearings can be used for all linear bushings, too.

Linear Bushings are delivered already filled with an anti-corrosion agent that is compatible with all petroleum-base lubricants.

Either oil or grease can be used as a lubricant. In most cases, the use of grease as a lubricant is preferable. The advantage of using grease rather than oil is that, being more viscous, grease helps to seal off the linear bushing and adheres better to the surfaces inside the bushing. In-service lubrication is therefore only required at long intervals.

Please observe the lubricant manufacturer's instructions for use. Linear Sets have been designed for use with grease lubricants. If oil is used instead, it is essential to check that all bushing surfaces and rolling elements are properly coated with lubricant.

Lubricating greases

We recommend the use of a grease to DIN 51825 as lubricant

- K2K,
- KP2K (for higher loads).

The table below gives examples of types of base grease for different applications.

Designation to DIN 51825	Thickener	Base oil	Service temperature range (°C)	Consistency class to DIN 51818	Drop point (°C)	High pressure characteristics	Suitability for anti-friction bearings	Field of application
K2K-30	Lithium soap (Li-12-oxy)	Petroleum base	-30 to 120	2	appr. 200	good	very good	Multi-purpose grease
K2K-60		Ester base*	-60 to 120	2	appr. 200	good	very good	Low temperatures, high velocities
KP2K-40	Lithium complex soap	Petroleum and/or synthetic base*	-40 to 120	2	appr. 240	good	very good	Higher loads

* Check the compatibility of the base oil with petroleum-base lubricants and anti-corrosion agents.

Oil lubricants

If exceptionally smooth running is demanded, oil may be used as a lubricant for the linear bushings.

Different types of oil and their viscosity ratings are listed below:

ISO viscosity class to DIN 51519	Kinematic viscosity at 40 °C (mm ² /s)	Field of application
ISO VG 32 ISO VG 68 ISO VG 100	32 68 100	For low friction and low loads
ISO VG 320 ISO VG 460	320 460	For low velocities and/or higher loads

Initial greasing and in-service lubrication

Whether grease is being applied for the first time or in-service, the shaft must always be inserted in the bushing. Add grease until the lubricant emerges.

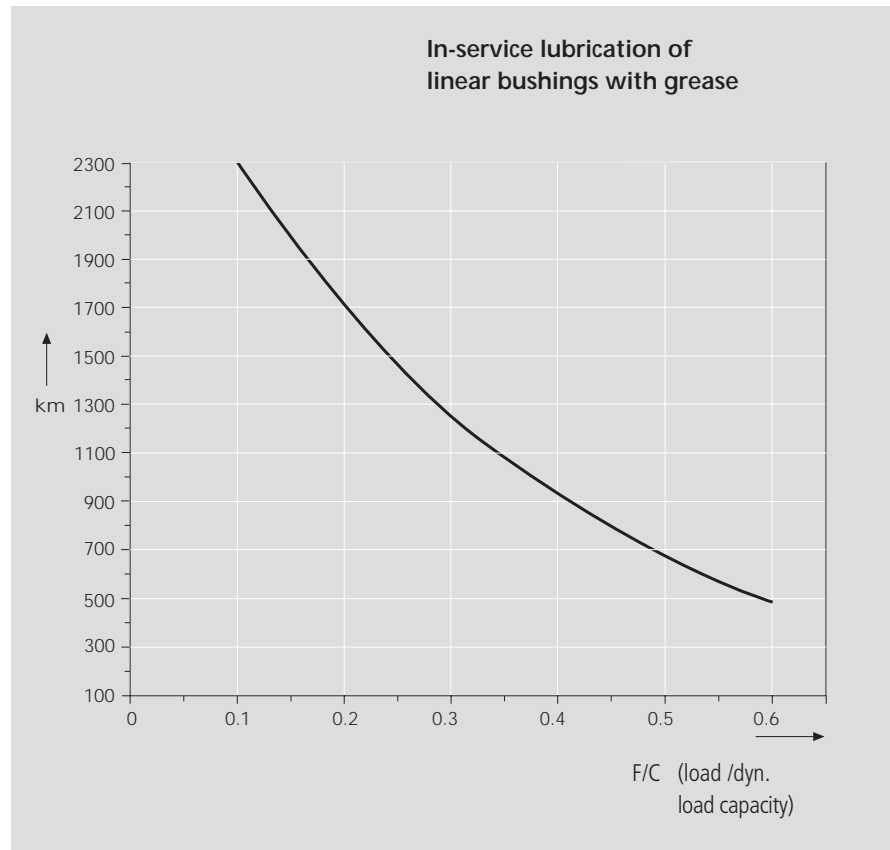

The chart gives guide values for in-service lubrication. Practical experience has shown that longer lubrication intervals can readily be achieved. These values presuppose careful initial greasing and regular checks on the lubrication condition.

There are many factors affecting in-service lubrication or a change of grease in linear bushings.

Some of these factors are listed below:

- load
- velocity
- motion sequence
- temperature

Short lubricating intervals are required in the following cases:

- high loads
- high velocity (up to v_{max})
- short stroke (stroke s is shorter than the length of the linear bushing)
- low resistance to aging in the lubricant

General Technical Data and Mounting Instructions

In-service lubrication options in linear bushings

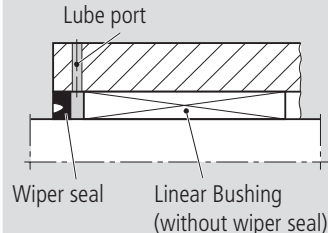
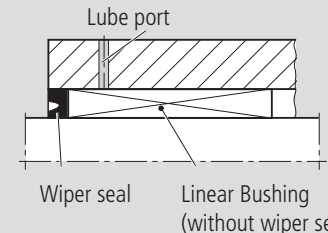
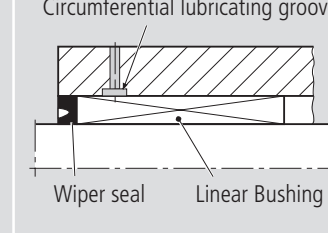
Type of Linear Bushing	Lubrication through gap between linear bushing and wiper seal 	Lubrication through lube port 	Lubrication through lube port with lubricating groove 
Standard			
– closed			
– adjustable		1 Locate the lube port near the slot (alignment during installation)	
– open			
Super ^A, ^B			
– closed		See Super Linear Bushings ^A and ^B – Technical Data – "customer-built housing"	
– open	1		
Super ^H, ^{SP}	See Super Linear Bushings ^H and ^{SP} – Lubrication and Retention		
Segmental			1 Locate the lube port along the visible ball recirculating track
Compact			1 Locate the lube port along the visible ball recirculating track
Radial		Lube port see Radial Linear Bushings	
	Axial retention of wiper seal and linear bushing required	Lubrication causes pressure to build up. Always check that the linear bushing and the wiper seal fit tight.	

Notes:

Make sure there is sufficient retention in open-type versions.
As far as possible, apply lubricant during longitudinal motion.
Lube ports and lube grooves must be free of burrs.

Grease nipples

Linear Sets designed for in-service lubrication are provided with lube holes for grease lubrication. Adequate grease nipples are shown in the below table:

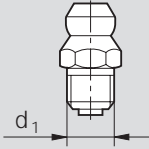
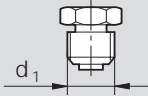
$\varnothing d_1$ (mm)	 cone-type grease nipple DIN 71412 type A part numbers	 funnel-type grease nipple DIN 3405 type A part numbers
M6	8417-002-02	8417-001-05
M8 x 1	8417-003-02	8417-003-05
M10 x 1	8417-009-02	—

Operating temperatures

Up to 100 °C; Standard Linear Bushings with wiper seals and separate wiper seals for Radial Linear Bushings: up to 80 °C (with brief peaks up to 100 °C). Higher temperatures are permissible only for sizes 12 to 80 Standard Linear Bushings without seals and at the cost of a reduction in load carrying capacity. (see temperature factor f_T).

Shaft deflection

In assemblies with rigid housings, etc., and long distances between shaft supports, shaft deflection and the resultant pressure between the bushing edge and the shaft will shorten the life of the assembly (this does not apply to Super Linear Bushings **A**, **H** and **SP** up to 30'). For information on how to calculate shaft deflection see Technical Data on Precision Steel Shafts.

Corrosion-resistant models

Corrosion-resistant steels are steels to DIN 17230 / EN 10088. In very critical, corrosive environments the parts must be checked under operating conditions. Use appropriate anti-corrosive agents and lubricants.

General Technical Data and Mounting Instructions

Installation of Linear Bushings

Two linear bushings are required for linear motion assemblies using one shaft only. Assemblies with two shafts must have at least one of the shafts mounted in two linear bushings.

To prevent distortion, which would increase running friction and shorten the service life of the assembly, special care must be taken to ensure precise spacing and parallelism between the two shafts with their associated linear bushings.

Recommended values for maximum spacing inaccuracy P, including deviation from parallelism, for assemblies incorporating linear bushings are as follows:

Shaft Ø d (mm)	P (µm)			
	Zero clearance		h7/H7	
	Standard, Super, Radial Linear Bushings	Segmental, Compact Linear Bushings	Standard, Super Linear Bushings	Segmental, Compact ¹⁾ Linear Bushings
5	4	–	12	–
8	4	–	12	–
10	4	–	12	–
12	5	8	13	17
16	5	8	13	17
20	7	12	15	20
25	9	15	17	23
30	9	15	17	23
40	11	18	19	25
50	13	22	21	28
60	16	–	24	–
80	22	–	30	–

¹⁾ For the "Compact RT" type, the values in the "Zero clearance" column apply.

Retention

See "Technical Data" of the various linear bushing types.

Points to note when mounting

The edge of the housing bore must be chamfered. The smaller sizes of linear bushing (but not the Compact series) can be inserted by hand. Use of an arbor is recommended for larger diameters and for the Compact Linear Bushings. Care should be taken not to exert pressure on the wiper seals and steel holding rings (Standard Linear Bushings), as this could damage the ball retainers. If a Compact Linear Bushing is slightly skewed on entering the housing bore, it will align itself as it is inserted further. Removal and re-alignment are unnecessary. Likewise with a view to preventing damage to the ball retainers and seals, care must be taken to ensure that the ends of the shaft are chamfered and that the Linear Bushing is not tilted when it is pushed onto the shaft. Hammers should never be used on the sleeve, holding rings or ball retainers of linear bushings, as this will invariably cause damage to the bushing. Linear bushings with seals must not be pushed onto the shaft over sharp edges, as the lips of the seals are extremely sensitive to damage. Radial and Torque-Resistant Linear Bushings must be mounted as described in the "Mounting instructions" in the relevant section.

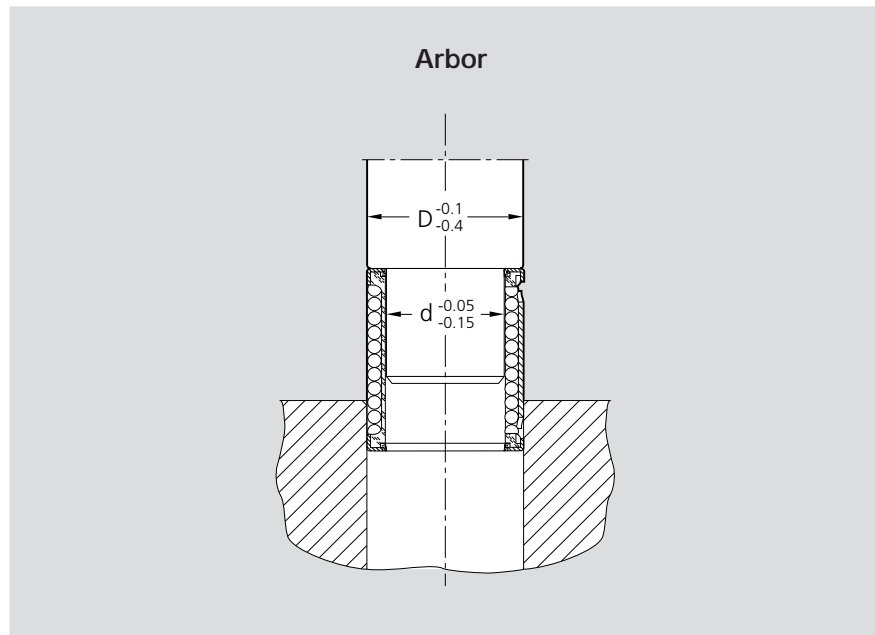

Radial clearance

Adjusting the radial clearance

The radial clearance values given in the tables have been obtained by statistical methods and are representative of the clearances to be expected in actual practice.

If an application calls for zero clearance, the radial clearance must be reduced by means of an adjusting screw in the bushing housing until a slight resistance is felt when the shaft is turned. In applications subject to vibration, the adjusting screw should be suitably secured against working loose once the desired clearance has been established.

The radial clearance of the closed-type Standard Linear Bushing is not adjustable.

Preload

If negative clearance (preload) is required, we recommend that zero clearance should be established as described above using a dummy shaft whose diameter is smaller by the amount of the desired preload than the actual guide shaft on which the linear bushing is to run.

Vertical dimensions

The tables for Linear Sets contain tolerance values for the height dimension 'H'. These tolerance values have been obtained by statistical methods and are representative of the values to be expected in actual practice.

General Technical Data and Mounting Instructions

Tolerances for inside dimensions

Tolerances in $\mu\text{m} = 0.001 \text{ mm}$

Rated dimensions (mm) G7	Tolerances for inside dimensions														
	H5	H6	H7	H8	H11	H12	H13	JS6	JS7	JS14	K6	K7	M6	P9	
between 3 and 6	+16 +4	+5 0	+8 0	+12 0	+18 0	+75 0	+120 0	+180 0	+4 -4	+6 -6	+150 -150	+2 -6	+3 -9	-1 -9	-12 -42
between 6 and 10	+20 +5	+6 0	+9 0	+15 0	+22 0	+90 0	+150 0	+220 0	+4.5 -4.5	+7.5 -7.5	+180 -180	+2 -7	+5 -10	-3 -12	-15 -51
between 10 and 18	+24 +6	+8 0	+11 0	+18 0	+27 0	+110 0	+180 0	+270 0	+5.5 -5.5	+9 -9	+215 -215	+2 -9	+6 -12	-4 -15	-18 -61
between 18 and 30	+28 +7	+9 0	+13 0	+21 0	+33 0	+130 0	+210 0	+330 0	+6.5 -6.5	+10.5 -10.5	+260 -260	+2 -11	+6 -15	-4 -17	-22 -74
between 30 and 50	+34 +9	+11 0	+16 0	+25 0	+39 0	+160 0	+250 0	+390 0	+8 -8	+12.5 -12.5	+310 -310	+3 -13	+7 -18	-4 -20	-26 -88
between 50 and 80	+40 +10	+13 0	+19 0	+30 0	+46 0	+190 0	+300 0	+460 0	+9.5 -9.5	+15 -15	+370 -370	+4 -15	+9 -21	-5 -24	-32 -106
between 80 and 120	+47 +12	+15 0	+22 0	+35 0	+54 0	+220 0	+350 0	+540 0	+11 -11	+17.5 -17.5	+435 -435	+4 -18	+10 -25	-6 -28	-37 -124
between 120 and 180	+54 +14	+18 0	+25 0	+40 0	+63 0	+250 0	+400 0	+630 0	+12.5 -12.5	+20 -20	+500 -500	+4 -21	+12 -28	-8 -33	-43 -143
between 180 and 250	+61 +15	+20 0	+29 0	+46 0	+72 0	+290 0	+460 0	+720 0	+14.5 -14.5	+23 -23	+575 -575	+5 -24	+13 -33	-8 -37	-50 -165

Conversion from millimeters to inches

	Millimeters	μm	Inches
1 millimeter	1	1000	0,0393701
1 μm	0.001	1	$3.93701 \cdot 10^{-5}$
1 inch	25.4	25400	1

Example of conversion from μm to inches:

Which are the tolerances (in inches) for a bore of 3.5 inch diameter?

Bore diameter 3.5 inch = $3.5 \cdot 25.4 \text{ mm} = 88.9 \text{ mm}$

For a bore diameter of 88.9 mm and a tolerance range of H7, the upper tolerance limit is +35 μm and the lower tolerance limit 0 μm

Max. offsize = $+35 \mu\text{m} = +35 \cdot 3.93701 \cdot 10^{-5} \text{ inch} = 1.3779 \cdot 10^{-3} \text{ inch}$

Min. offsize = 0 μm

Tolerances for outside dimensions

Tolerances in $\mu\text{m} = 0.001 \text{ mm}$

Rated dimensions (mm)	Tolerances for outside dimensions														
	g7	h5	h6	h7	h8	h11	h12	h13	js6	js7	js14	k6	k7	m6	p9
between 3 and 6	-4 -16	0 -5	0 -8	0 -12	0 -18	0 -75	0 -120	0 -180	+4 -4	+6 -6	+150 -150	+9 +1	+13 +1	+12 +4	+42 +12
between 6 and 10	-5 -20	0 -6	0 -9	0 -15	0 -22	0 -90	0 -150	0 -220	+4.5 -4.5	+7.5 -7.5	+180 -180	+10 +1	+16 +1	+15 +6	+51 +15
between 10 and 18	-6 -24	0 -8	0 -11	0 -18	0 -27	0 -110	0 -180	0 -270	+5.5 -5.5	+9 -9	+215 -215	+12 +1	+19 +1	+18 +7	+61 +18
between 18 and 30	-7 -28	0 -9	0 -13	0 -21	0 -33	0 -130	0 -210	0 -330	+6.5 -6.5	+10.5 -10.5	+260 -260	+15 +2	+23 +2	+21 +8	-
between 30 and 50	-9 -34	0 -11	0 -16	0 -25	0 -39	0 -160	0 -250	0 -390	+8 -8	+12.5 -12.5	+310 -310	+18 +2	+27 +2	+25 +9	-
between 50 and 80	-10 -40	0 -13	0 -19	0 -30	0 -46	0 -190	0 -300	0 -460	+9.5 -9.5	+15 -15	+370 -370	+21 +2	+32 +2	+30 +11	-
between 80 and 120	-12 -47	0 -15	0 -22	0 -35	0 -54	0 -220	0 -350	0 -540	+11 -11	+17.5 -17.5	+435 -435	+25 +3	+38 +3	+35 +13	-
between 120 and 180	-14 -54	0 -18	0 -25	0 -40	0 -63	0 -250	0 -400	0 -630	+12.5 -12.5	+20 -20	+500 -500	+28 +3	+43 +3	+40 +15	-
between 180 and 250	-15 -61	0 -20	0 -29	0 -46	0 -72	0 -290	0 -460	0 -720	+14.5 -14.5	+23 -23	+575 -575	+33 +4	+50 +4	+46 +17	-

Note:

This catalog refers to the new ISO standards throughout. In some cases, however, the old standards are still used in actual practice. The correspondence between standards is given below.

	New designation	Old designation
Hexagon socket head cap screws	ISO 4762	DIN 912
Hexagon head screws	ISO 4017	DIN 933

STAR – Standard Linear Bushings

Standard Linear Bushings have a service history that goes back over several decades and covers successful employment in all fields of mechanical engineering, in the construction of special machinery, jigs and equipment. Made entirely of solid metal, Standard Linear Bushings are especially suited for applications requiring a rugged construction and a high degree of insensitivity to dirt. Long service life, precision and high efficiency are the classical features characterizing these guide elements.

The Linear Bushing for extra-sturdy linear motion assemblies

The Standard Linear Bushing consists of:

- a hardened and ground outer sleeve
- a steel ball retainer (plastic ball retainer in sizes 5 and 8)
- balls made of anti-friction bearing steel
- steel snap rings or wiper-type seal rings

Types

- Closed
- Adjustable (slotted)
- Open
- With or without seals
- Various types of screw-mounting Linear Sets (Standard Linear Bushing with Precision Housing)
- **Adjustable and open-type Standard Linear Bushings are also available with STAR Resist corrosion protection (yellow chromated zinc-iron coating) and a special version (black chromated)**



Advantages

- Long service life
- Low friction
- High running speed
- Sturdy solid-metal construction suited to industrial workshop environments
- Withstands temperatures above 100 °C
- Insensitive to dirt, an especially important feature in woodworking machines

Adjustable (slotted) type



Open type



STAR – Standard Linear Bushings

Technical Data

Please observe the general technical principles and mounting instructions at the beginning of this catalog as well as the additional technical data given below.

Outer dimensions/interchangeability

Standard Linear Bushings have the same outer dimensions and are therefore interchangeable with Super Linear Bushings (caution: different retention, radial clearance, load capacities and lubrication).

Sealing

Standard Linear Bushings are available with seals. Open-type Standard Linear Bushings in sizes 20 to 80 can also be supplied fully sealed (with seal strip), though this will result in greater friction.

Low friction

Very low friction due to the rolling friction principle. Even if the lubricant supply were to run short, there would be no appreciable increase in friction. Extremely low breakaway forces.

The friction μ of unsealed Standard Linear Bushings using oil as a lubricant lies between 0.001 and 0.004.

The friction is lowest under high load. It may, however, be greater than the stated value when only a slight load is applied.

The frictional drag in linear bushings sealed at both ends and not subject to radial loading depends on the speed and the type of lubrication and is shown in the below table.

Shaft Ø d (mm)	Closed and adjustable type		Open type	
	Breakaway force (N) approx.	Frictional drag (N) approx.	Breakaway force (N) approx.	Frictional drag (N) approx.
5	0.8	0.4	–	–
8	1	0.5	–	–
12	6	2	8	3
16	9	3	12	4
20	12	4	16	6
25	14	5	19	7
30	18	6	24	8
40	24	8	32	11
50	30	10	40	14
60	36	12	48	16
80	45	15	60	20

Velocity and acceleration

Type	v_{\max} (m/s)	a_{\max} (m/s ²)
Standard Linear Bushing $d \leq 40$ mm	2.5	100
Standard Linear Bushing $d \geq 50$ mm	2	50

Operating temperatures

Linear bushings without seals: up to 100 °C. Higher temperatures are permissible for sizes 12 to 80 though at the cost of reduced load capacity (see temperature factor f_t in "General Technical Data and Mounting Instructions").

Linear bushings with seals: up to 80 °C (brief peaks up to 100 °C).

Direction of load and its influence on the load-carrying capacity of closed and adjustable Standard Linear Bushings

The load capacities given are valid for installation in "min" position and should be taken as the basis for calculation.

In applications where the direction of load is exactly known and where the Standard Linear Bushings can be mounted in the "max" position, the load capacity rating must be multiplied by the factors f_{max} (dynamic load capacity C) or f_{0max} (static load capacity C_0) from the table.

Shaft Ø d (mm)	Load capacity factors	
	f_{max}	f_{0max}
5, 8, 12, 16	1.15	1.42
20, 25	1.19	1.46
30, 40, 50, 60, 80	1.06	1.28



Direction of load and its influence on the load-carrying capacity of open Standard Linear Bushings

The load capacities C and C_0 apply when the load is acting along the line $\varrho = 0^\circ$.

If the load is acting in any other direction, these load capacities must be multiplied by the factors f_ϱ (dynamic load capacity C) or $f_{\varrho 0}$ (static load capacity C_0).

A reduction in the load capacity can be avoided by selective circumferential positioning of the Standard Linear Bushing (see Linear Sets with side opening).

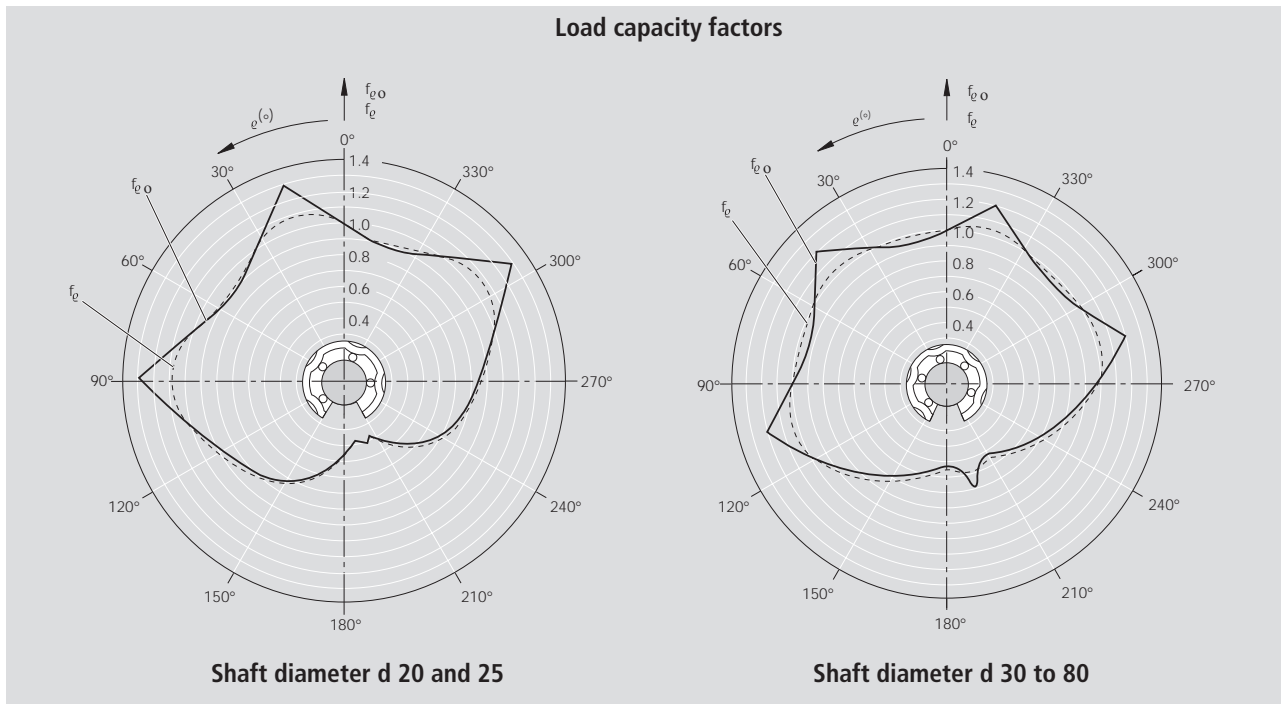

STAR – Standard Linear Bushings

Customer-built Housing

Retention

Standard Linear Bushings

closed type

adjustable

- Retaining rings
- Metal case
- Special arrangement

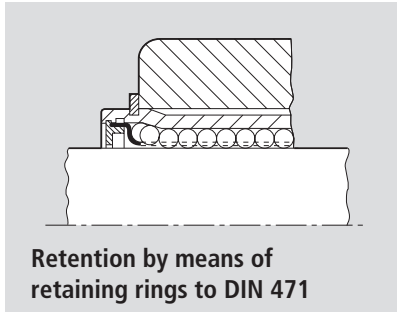

Retention by means of retaining rings to DIN 471

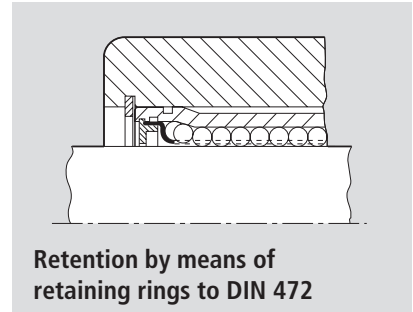

Retention by means of retaining rings to DIN 472

Shaft Ø d (mm)	Retaining rings DIN 471		Retaining rings DIN 472	
	Part numbers	Dimensions	Part numbers	Dimensions
5	8410-712-00	12 x 1	8410-207-00	12 x 1
8	8410-713-00	16 x 1	8410-208-00	16 x 1
12	8410-714-00	22 x 1.2	8410-209-00	22 x 1
16	8410-715-00	27 x 1.2 ¹⁾	8410-210-00	26 x 1.2
20	8410-716-00	33 x 1.5 ¹⁾	8410-211-00	32 x 1.2
25	8410-717-00	42 x 1.75	8410-212-00	40 x 1.75
30	8410-718-00	48 x 1.75	8410-213-00	47 x 1.75
40	8410-719-00	62 x 2	8410-214-00	62 x 2
50	8410-720-00	75 x 2.5	8410-215-00	75 x 2.5
60	8410-721-00	90 x 3	8410-216-00	90 x 3
80	8410-722-00	120 x 4	8410-217-00	120 x 4

¹⁾ not to DIN 471

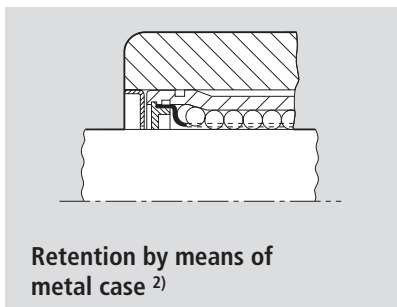

Retention by means of metal case ²⁾

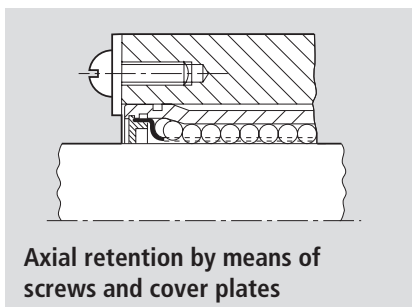

Axial retention by means of screws and cover plates

²⁾ For part numbers and dimensions refer to Super Linear Bushings **A** and **B**, customer-built housings

Standard Linear Bushings

open type

- Dimensions of retention hole

The open-type linear bushing has been provided with a retention hole, thus allowing axial and radial securing.

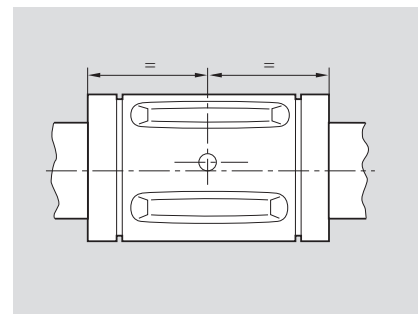
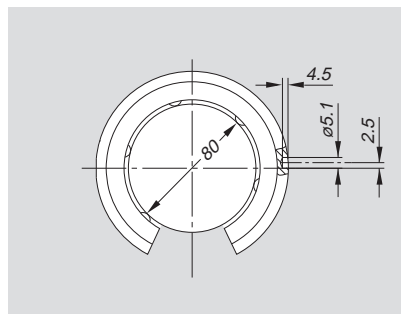
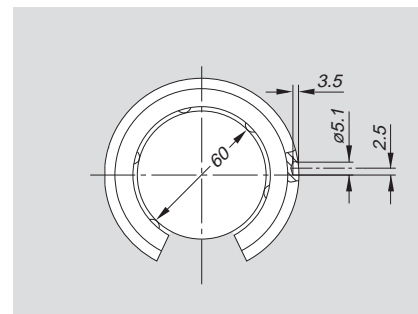
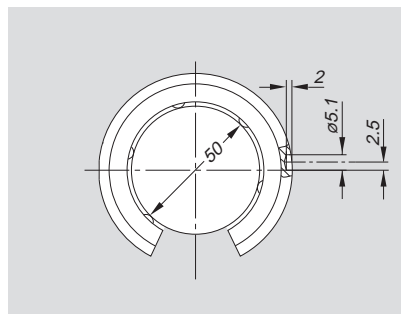
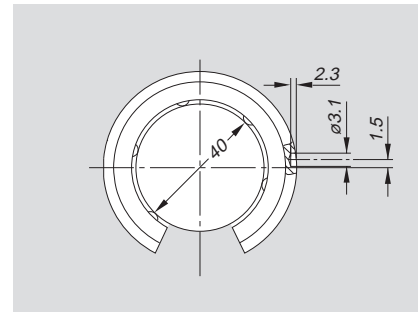
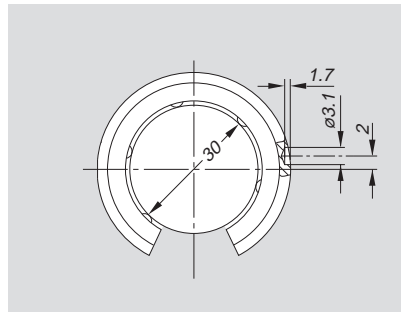
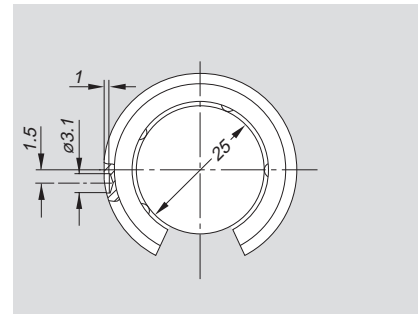
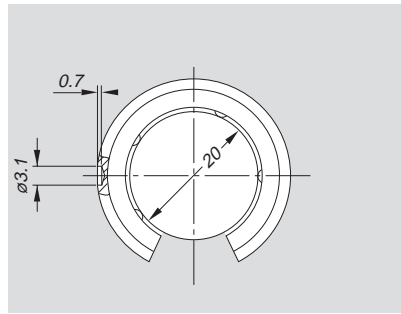

STAR – Standard Linear Bushings

Customer-built Housings

- Retention by means of locating screw

Points to note when mounting:
 Open-type Standard Linear Bushings have been provided with the necessary retention hole. On installation, the retention hole in the Linear Bushing must be aligned with the tapped hole in the housing. The screw is then inserted, screwed down to the specified depth and tightened to the specified torque.

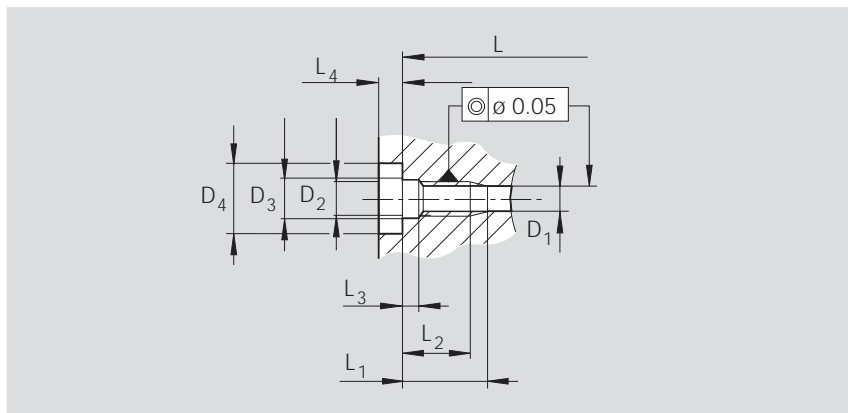
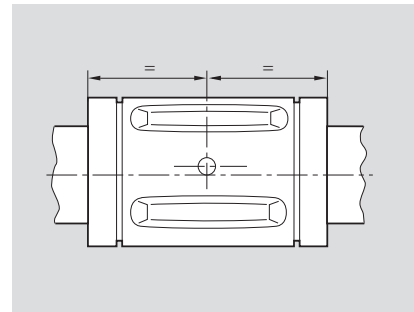
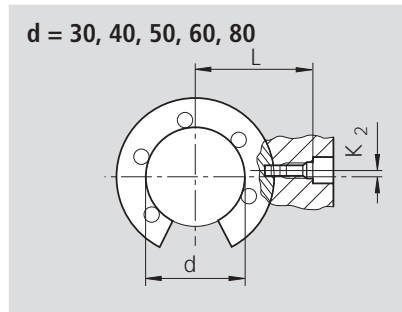
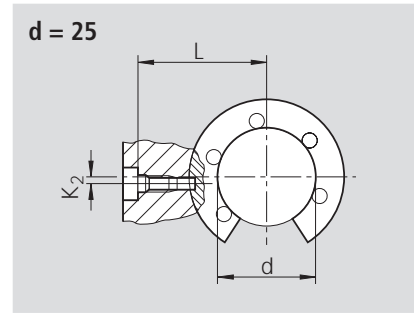
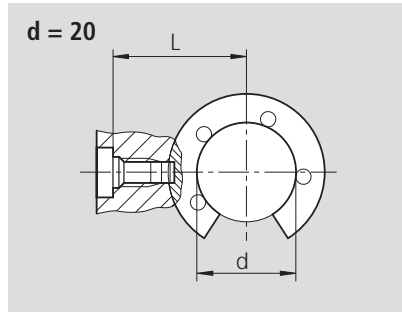

Shaft Ø d (mm)	Dimensions (mm)										Locating screw	
	L	K ₂	L ₁	L ₂	L ₃	L ₄	D ₁	D ₂	D ₃	D ₄	Part number	Tightening torque (Nm)
20	25.5 _{-0.1}	0	8.5 ^{+0.2}	6.5	1.3	2.5	3.1	M4	4.5	8	8429-009-01	1.9
25	33.05 _{-0.1}	1.5	10 ^{+0.2}	8	2	3.2	3.1	M4	4.5	8	8427-009-09	1.9
30	36 _{-0.15}	2	10 ^{+0.2}	8	2	3.2	3.1	M4	4.5	8	8427-009-09	1.9
40	42.9 _{-0.15}	1.5	10 ^{+0.2}	8	2	3.2	3.1	M4	4.5	8	8427-009-09	1.9
50	58.5 _{-0.2}	2.5	17.5 ^{+0.5}	13.5	3.7	6	5.1	M8	9	15	8427-005-09	16
60	71.5 _{-0.25}	2.5	17.5 ^{+0.5}	13.5	3.7	6	5.1	M8	9	15	8427-006-09	16
80	85.5 _{-0.25}	2.5	17.5 ^{+0.5}	13.5	3.7	6	5.1	M8	9	15	8427-006-09	16

Locating screws

for shaft $\varnothing 20$

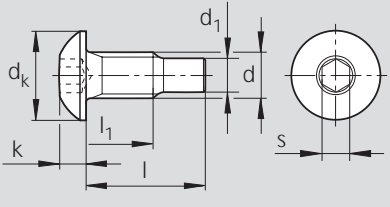

for shaft $\varnothing 25, 30, 40, 50, 60, 80$

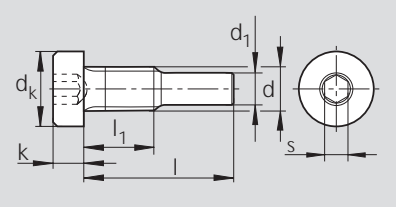

Shaft $\varnothing d$ (mm)	Part numbers	Dimensions (mm)							Tightening torque (Nm)
		d	d _k	d ₁	l	l ₁	k	s	
20	8429-009-01	M4	7.6	3	10.15	5.7	2.2	2.5	1.9
25, 30, 40	8427-009-09	M4	7	3	14.1	6.5	2.8	2.5	1.9
50	8427-005-09	M8	13	5	22.8	12.5	5	5	16
60, 80	8427-006-09	M8	13	5	29.7	12.5	5	5	16



The locating screws are of the self-locking type.

- Axial retention by means of screws and cover plates, rotary retention by means of pin or plates.

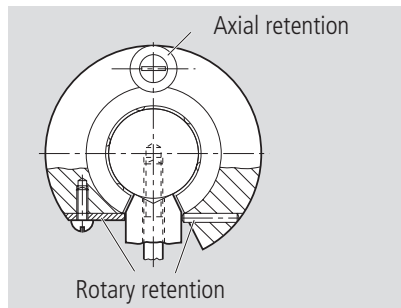

STAR – Standard Linear Bushings

Standard Linear Bushings, 0600-closed type, without seals

Standard Linear Bushings, 0602-closed type, with seals

Structural design

- Hardened and ground outer sleeve
- Steel ball retainer (plastic ball retainer in sizes 5 and 8)
- Balls made of anti-friction bearing steel
- Steel holding rings or seals
- Closed version, for use on unsupported shafts

Ordering data



Shaft Ø d (mm)	Part numbers		Mass (kg)
	without seals	with two seals	
5	0600-305-00	0602-305-10	0.01
8	0600-308-00	0602-308-10	0.02
12	0600-012-00	0602-012-10	0.04
16	0600-016-00	0602-016-10	0.05
20	0600-020-00	0602-020-10	0.10
25	0600-025-00	0602-025-10	0.19
30	0600-030-00	0602-030-10	0.32
40	0600-040-00	0602-040-10	0.62
50	0600-050-00	0602-050-10	1.14
60	0600-060-00	0602-060-10	2.11
80	0600-080-00	0602-080-10	4.70

With one seal 0601-...-10

The figures for dynamic load-carrying capacity have been calculated assuming a nominal travel of 100,000 m. For a nominal travel of 50,000 m, the 'C' figures in the table must be multiplied by a factor of 1.26.

Dimensions

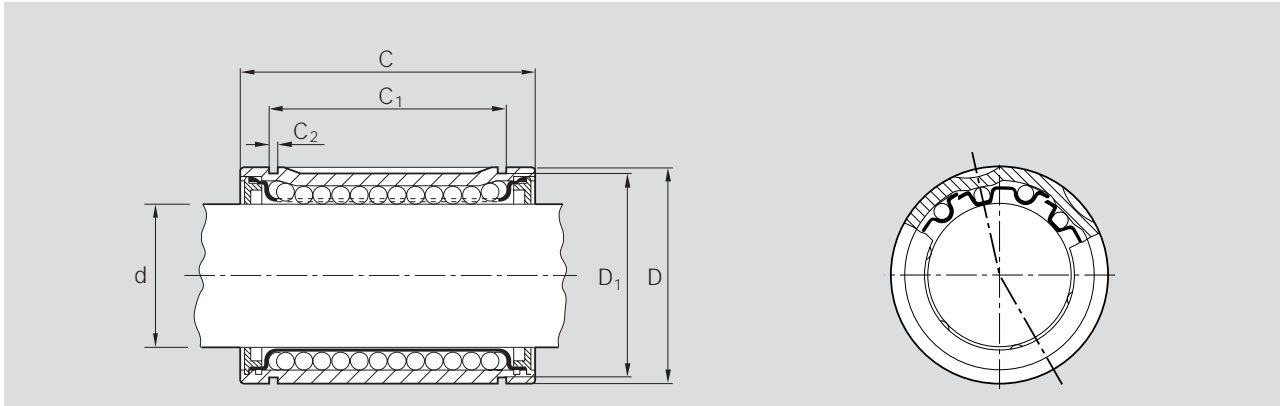

Ø d	Dimensions (mm)					No. of ball circuits	Working bore diameter tolerance (µm)	Radial clearance ²⁾ (µm)		Load capacities ³⁾	
	D h5	C h12	C ₁ H13	C ₂	D ₁			h6	h7	dyn. C (N)	stat. C ₀ (N)
5 ¹⁾	12	22	14.2	1.1	11.1	4	+11 +1	+16 +4	+20 +4	180	140
8 ¹⁾	16	25	16.2	1.1	14.7	4	+12 +2	+18 +5	+24 +5	320	240
12	22	32	22.6	1.3	20.5	4	+12 +2	+20 +5	+26 +6	420	280
16	26	36	24.6	1.3	24.9	4	+14 +2	+22 +5	+28 +6	580	440
20	32	45	31.2	1.6	30.5	5	+14 +2	+23 +6	+31 +6	1170	860
25	40	58	43.7	1.85	38.5	5	+16 +2	+25 +6	+32 +7	2080	1560
30	47	68	51.7	1.85	44.5	6	+16 +2	+25 +6	+32 +7	2820	2230
40	62	80	60.3	2.15	58	6	+19 +2	+30 +7	+38 +8	5170	3810
50	75	100	77.3	2.65	71	6	+19 +2	+30 +7	+38 +8	8260	6470
60	90	125	101.3	3.15	85	6	+19 +2	+33 +7	+43 +8	11500	9160
80	120	165	133.3	4.15	114	6	+24 +2	+37 +8	+47 +9	21000	16300

¹⁾ Sizes 5 and 8 have a plastic ball retainer.

²⁾ Statistically determined from the working bore diameter and shaft tolerance. Recommended housing bore tolerance: H6 or H7.

³⁾ The load capacities stated are minimum values as the position and direction of load cannot always be precisely defined.

STAR – Standard Linear Bushings

Standard Linear Bushings, 0610-adjustable, without seals

Standard Linear Bushings, 0612-adjustable, with seals

Structural design

- Hardened and ground outer sleeve
- Steel ball retainer (plastic ball retainer in sizes 5 and 8)
- Balls made of anti-friction bearing steel
- Steel holding rings or seals
- Adjustable radial clearance

Ordering data

adjustable type



Shaft Ø d (mm)	Part numbers		Mass (kg)
	without seals	with two seals	
5	0610-305-00	0612-305-10	0.01
8	0610-308-00	0612-308-10	0.02
12	0610-012-00	0612-012-10	0.04
16	0610-016-00	0612-016-10	0.05
20	0610-020-00	0612-020-10	0.10
25	0610-025-00	0612-025-10	0.19
30	0610-030-00	0612-030-10	0.32
40	0610-040-00	0612-040-10	0.62
50	0610-050-00	0612-050-10	1.14
60	0610-060-00	0612-060-10	2.11
80	0610-080-00	0612-080-10	4.70

With one seal: 0611-...-10.

The figures for dynamic load-carrying capacity have been calculated assuming a nominal travel of 100,000 m. For a nominal travel of 50,000 m, the 'C' figures in the table must be multiplied by a factor of 1.26.

Dimensions

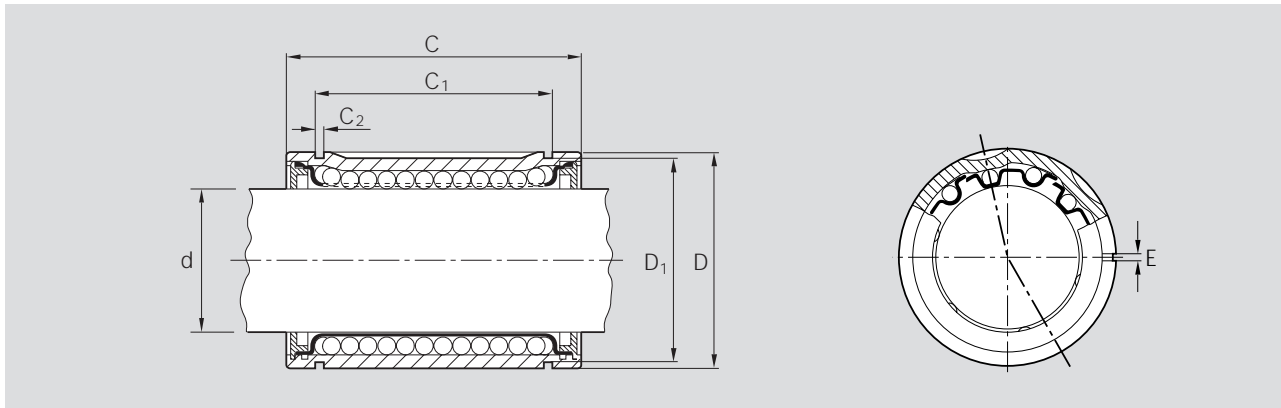

Ø d	Dimensions (mm)						No. of ball circuits	Load capacities ³⁾		Adjustable radial clearance (shaft/bore) (µm)					
	D ²⁾ h5	C h12	C ₁ H13	C ₂	D ₁	E		dyn. C (N)	stat. C ₀ (N)						
										h6/H6	h6/JS6	h6/K6	h7/H7	h7/JS7	h7/K7
5 ¹⁾	12	22	14.2	1.1	11.1	1.5	4	180	140	+28 +10	+23 +4	+19 +1	+37 +12	+28 +3	+25 0
8 ¹⁾	16	25	16.2	1.1	14.7	1.5	4	320	240	+31 +11	+25 +6	+22 +2	+41 +14	+32 +5	+29 +2
12	22	32	22.6	1.3	20.5	1.5	4	420	280	+34 +13	+28 +6	+23 +2	+46 +16	+36 +5	+31 +1
16	26	36	24.6	1.3	24.9	1.5	4	580	440	+36 +13	+29 +7	+25 +2	+48 +16	+37 +6	+33 +1
20	32	45	31.2	1.6	30.5	2.0	5	1170	860	+41 +15	+33 +7	+28 +2	+55 +18	+42 +6	+37 0
25	40	58	43.7	1.85	38.5	2.0	5	2080	1560	+43 +15	+35 +7	+30 +2	+56 +19	+44 +6	+38 +1
30	47	68	51.7	1.85	44.5	2.0	6	2820	2230	+43 +15	+35 +7	+30 +2	+56 +19	+44 +6	+38 +1
40	62	80	60.3	2.15	58	2.0	6	5170	3810	+51 +18	+41 +9	+36 +3	+67 +22	+52 +7	+46 +1
50	75	100	77.3	2.65	71	2.0	6	8260	6470	+51 +18	+41 +9	+36 +3	+67 +22	+52 +7	+46 +1
60	90	125	101.3	3.15	85	2.0	6	11500	9160	+57 +20	+46 +9	+39 +2	+76 +25	+59 +7	+51 0
80	120	165	133.3	4.15	114	2.0	6	21000	16300	+61 +21	+50 +10	+43 +3	+80 +26	+62 +9	+55 +1

¹⁾ Sizes 5 and 8 have a plastic ball retainer.

²⁾ The tolerance stated is valid for the Linear Bushing in the unslotted condition.

³⁾ The load capacities stated are minimum values as the position and direction of load cannot always be precisely defined.

STAR – Standard Linear Bushings

**Standard Linear Bushings, 0630-
open type, without seals**

**Standard Linear Bushings, 0632-
open type, with seals**

Structural design

- Hardened and ground outer sleeve
- Steel ball retainer
- Balls made of anti-friction bearing steel
- Steel holding rings or seals
- With bore for axial and radial retention (except sizes 12 and 16)

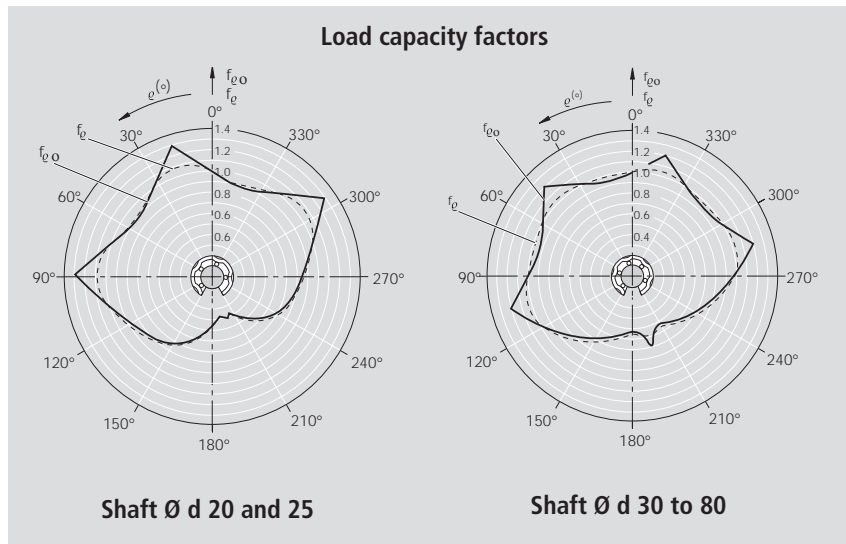

Ordering data



Shaft Ø d (mm)	Part numbers			Mass (kg)
	without seals	with two seals	fully sealed	
12 ¹⁾	0630-012-00	0632-012-00	–	0.03
16 ¹⁾	0630-016-00	0632-016-00	–	0.04
20	0630-020-00	0632-020-00	0632-020-05	0.08
25	0630-025-00	0632-025-00	0632-025-05	0.15
30	0630-030-00	0632-030-00	0632-030-05	0.26
40	0630-040-00	0632-040-00	0632-040-05	0.52
50	0630-050-00	0632-050-00	0632-050-05	0.95
60	0630-060-00	0632-060-00	0632-060-05	1.76
80	0630-080-00	0632-080-00	0632-080-05	3.92

¹⁾ without bore for axial and radial retention

With one seal 0631-...-00

The figures for dynamic load-carrying capacity have been calculated assuming a nominal travel of 100,000 m. For a nominal travel of 50,000 m, the 'C' figures in the table must be multiplied by a factor of 1.26.

Dimensions

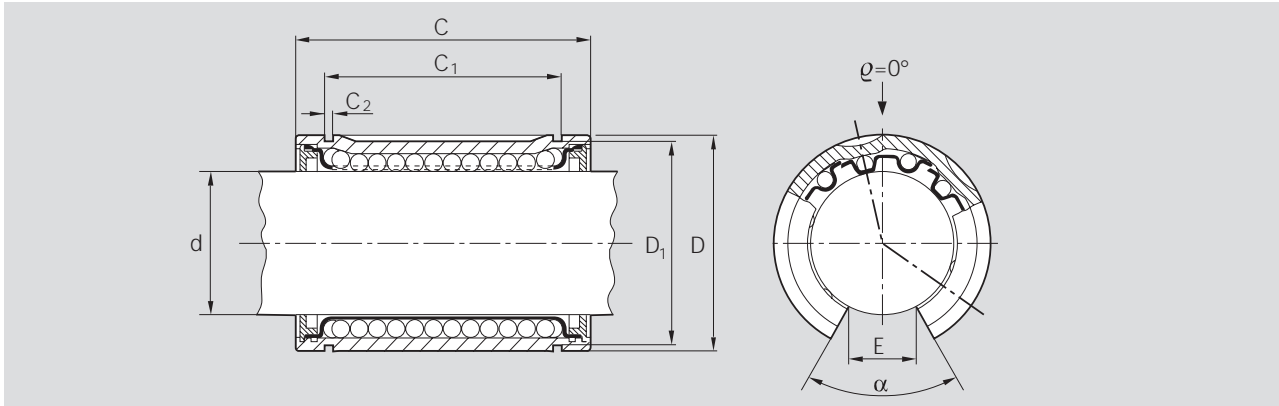

Ø d	Dimensions (mm)						Angle (°)	No. of ball circuits	Load capacities ³⁾		Adjustable radial clearance (shaft/bore) (µm)					
	D ¹⁾ h5	C h12	C ₁ H13	C ₂	D ₁	E ²⁾			dyn. C (N)	stat. C ₀ (N)	h6/H6	h6/JS6	h6/K6	h7/H7	h7/JS7	h7/K7
12	22	32	22.6	1.3	20.5	7.5	78	3	430	290	+34 +13	+28 +6	+23 +2	+46 +16	+36 +5	+31 +1
16	26	36	24.6	1.3	24.9	10.0	78	3	600	450	+36 +13	+29 +7	+25 +2	+48 +16	+37 +6	+33 +1
20	32	45	31.2	1.6	30.5	10.0	60	4	1280	970	+41 +15	+33 +7	+28 +2	+55 +18	+42 +6	+37 0
25	40	58	43.7	1.85	38.5	12.5	60	4	2270	1750	+43 +15	+35 +7	+30 +2	+56 +19	+44 +6	+38 +1
30	47	68	51.7	1.85	44.5	12.5	50	5	2890	2390	+43 +15	+35 +7	+30 +2	+56 +19	+44 +6	+38 +1
40	62	80	60.3	2.15	58	16.8	50	5	5280	4000	+51 +18	+41 +9	+36 +3	+67 +22	+52 +7	+46 +1
50	75	100	77.3	2.65	71	21.0	50	5	8470	6900	+51 +18	+41 +9	+36 +3	+67 +22	+52 +7	+46 +1
60	90	125	101.3	3.15	85	27.2	54	5	11800	9780	+57 +20	+46 +9	+39 +2	+76 +25	+59 +7	+51 0
80	120	165	133.3	4.15	114	36.3	54	5	21500	17400	+61 +21	+50 +10	+43 +3	+80 +26	+62 +9	+55 +1

¹⁾ The tolerance stated is valid for the Linear Bushing in the unslotted condition.

²⁾ Lower limit relative to nominal shaft dimension d.

³⁾ The load capacities C and C₀ apply only when the load is acting along the line $q = 0^\circ$.
If the load is acting in any other direction, these load capacities must be multiplied by the factor f_q or f_{e0} .

For loads acting on the opening in sizes 12 and 16:
 $q = 180^\circ$
 $f_q = 0.37$

Sizes 12 and 16 must be mounted as shown here (mirror-symmetrically) to prevent their lifting from the shaft. It is not possible to adjust a single linear bushing (with slotted housing adjustable by means of an adjusting screw) to zero clearance.

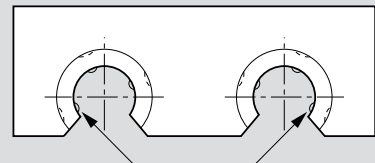

STAR – Linear Sets with Standard Linear Bushings

Overview

Linear Sets

Closed type

Standard type with fixed working bore diameter.

Adjustable type

For use when zero clearance or preload is required.

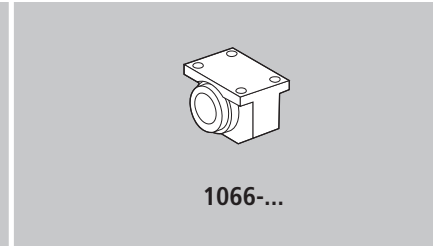
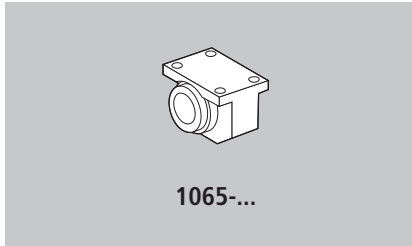

Open type

For long guideways when the shafts must be supported and high rigidity is required.

Open type, adjustable

For use when zero clearance or preload is required.

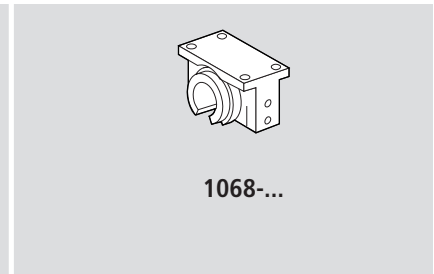
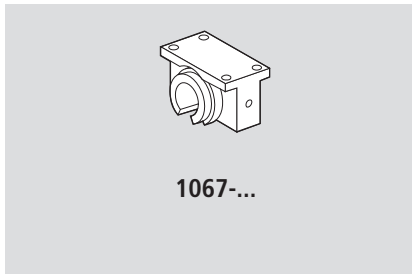

With side opening

The load carrying capacity of open linear bushings is reduced when the load is applied to the "open" portion of the bushing. The Linear Set with Side Opening has been developed to overcome this disadvantage and to permit selective circumferential positioning of the open linear bushing.

With side opening, adjustable

For use when zero clearance or preload is required.

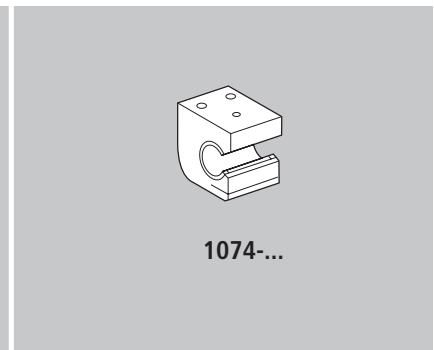
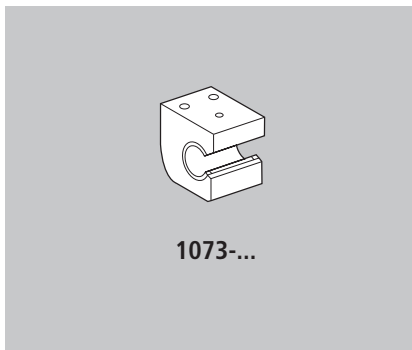

Flanged type

This element was developed as a complement to our Linear Set series for use in applications requiring the shaft to be arranged at right angles to the mounting base.

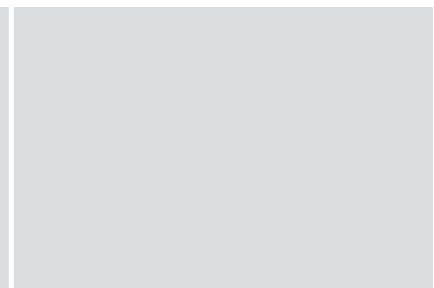

Advantages/Technical Data/Notes for Mounting

Advantages

- Thanks to their special material and sturdy wall thickness, Precision Housings offer very high rigidity regardless of the direction of loading, even when the load carrying capacity of the assembly is exploited to the full.
- The housings are easy to align during mounting, so that no adverse stress is exerted on the linear bushing.
- Their high precision guarantees trouble-free running of our linear bushings and full interchangeability of all units.
- Since our housings are produced in large numbers, they offer the same high quality as the user's own design at a price that no in-house design can match for economy.

Technical data

Operating temperatures

80 °C, with brief peaks up to 100 °C



Notes for mounting

Radial clearance

The radial clearance values given in the tables have been obtained by statistical methods and are representative of the values to be expected in actual practice. STAR Linear Sets 1066-...-, 1068-...- and 1074-...00 are adjusted to zero clearance on a shaft of diameter accurate to a tolerance of h5 (lower limit) before leaving the factory.

Vertical dimensions

The tables for Linear Sets contain tolerance values for the height dimension 'H'. These tolerance values have been obtained by statistical methods and are representative of the values to be expected in actual practice.

Screws

We recommend screws to ISO 4762-8.8 for mounting Linear Sets.

STAR – Linear Sets with Standard Linear Bushings

Linear Sets, 1065-closed type

Linear Sets, 1066-adjustable type

Structural design

- Precision Housing (lamellar graphite cast iron)
- Standard Linear Bushing with seals
- Two retaining rings

Ordering data

closed type



Shaft Ø d (mm)	Part numbers with two seals	Mass (kg)
8	1065-208-00	0.09
12	1065-212-00	0.16
16	1065-216-00	0.27
20	1065-220-00	0.45
25	1065-225-00	0.89
30	1065-230-00	1.33
40	1065-240-00	2.51
50	1065-250-00	3.68
60	1065-260-00	6.73
80	1065-280-00	15.32

adjustable type



Shaft Ø d (mm)	Part numbers with two seals	Mass (kg)
8	1066-208-00	0.09
12	1066-212-00	0.16
16	1066-216-00	0.27
20	1066-220-00	0.45
25	1066-225-00	0.89
30	1066-230-00	1.33
40	1066-240-00	2.51
50	1066-250-00	3.68
60	1066-260-00	6.73
80	1066-280-00	15.32

The figures for dynamic load-carrying capacity have been calculated assuming a nominal travel of 100,000 m. For a nominal travel of 50,000 m, the 'C' figures in the table must be multiplied by a factor of 1.26.

Dimensions

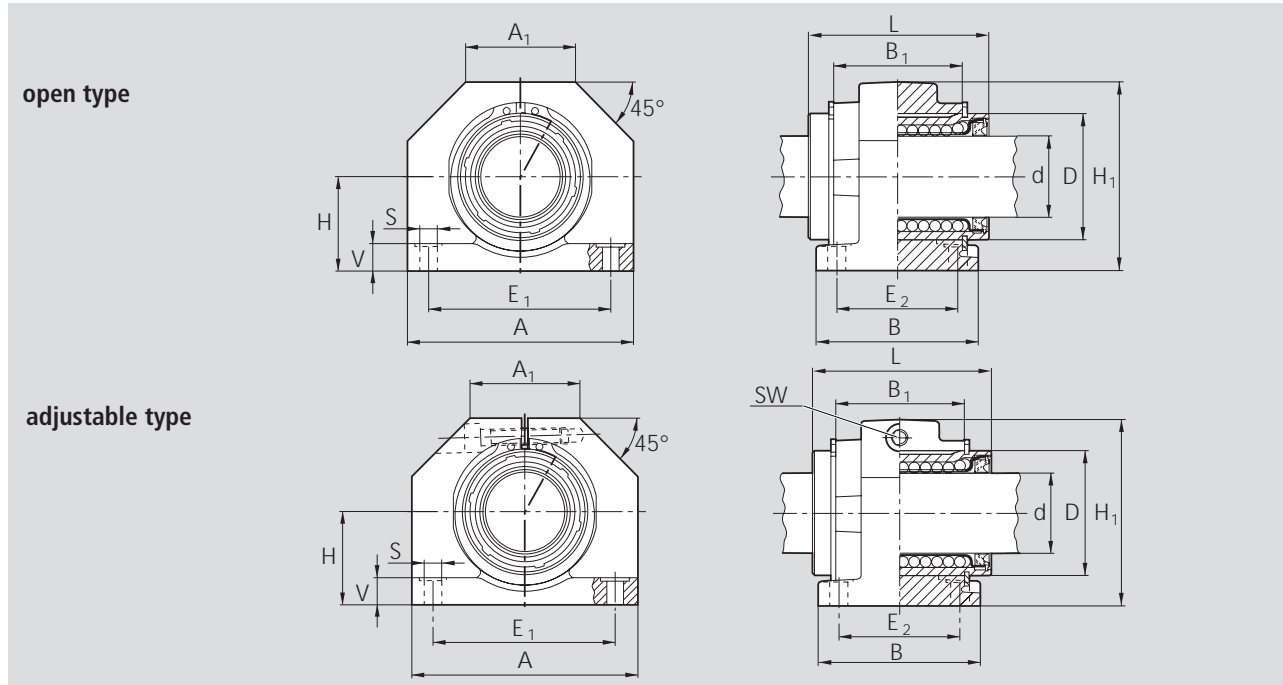

Ø d	Dimensions (mm)													Radial clearance ²⁾ (µm)		Tolerance (µm) for dimension H ³⁾	Load capacities ⁴⁾ (N)		
	D	H	H ₁ ¹⁾	L	A ¹⁾	A ₁ ¹⁾	B ¹⁾	B ₁	E ₁	E ₂	S	V ¹⁾	SW	1065-... with shaft h6	1066-... h7		dyn. C	stat. C ₀	
8	16	15	28	25	32	16	28	14	25±0.15	20±0.15	3.4	5	2	+18 +5	+24 +5	+6 -17	320	240	
12	22	18	35	32	42	21	32	20	32±0.15	23±0.15	4.5	5.5	2.5	+20 +5	+26 +6	adjusted prior to delivery to zero clearance on h5 shaft (lower limit) when screwed down	420	280	
16	26	22	42	36	50	26	35	22	40±0.15	26±0.15	4.5	6.5	3	+22 +5	+28 +6		+5 -18	580	440
20	32	25	50	45	60	28	42	28	45±0.15	32±0.15	4.5	8	3	+23 +6	+31 +6		+5 -19	1170	860
25	40	30	60	58	74	38	54	40	60±0.15	40±0.15	5.5	9	5	+25 +6	+32 +7		+5 -19	2080	1560
30	47	35	70	68	84	41	60	48	68±0.20	45±0.20	6.6	10	5	+25 +6	+32 +7		+5 -19	2820	2230
40	62	45	90	80	108	51	78	56	86±0.20	58±0.20	9	12	6	+30 +7	+38 +8		+4 -21	5170	3810
50	75	50	105	100	130	57	70	72	108±0.20	50±0.20	9	14	8	+30 +7	+38 +8		+8 -25	8260	6470
60	90	60	125	125	160	70	92	95	132±0.25	65±0.25	11	15	10	+33 +7	+43 +8		+8 -26	11500	9160
80	120	80	170	165	200	85	122	125	170±0.50	90±0.50	13.5	22	14	+37 +8	+47 +9		+7 -28	21000	16300

¹⁾ Tolerance to DIN 1686-GTB 15.

²⁾ Statistically determined from the working bore diameter and shaft tolerances. Taking the Linear Bushing outer diameter and the housing bore into consideration, the radial clearance values for shaft h7 are similar to those given for the Standard Linear Bushing 0610-... in the "h7/H7" column under the heading "Adjustable radial clearance".

³⁾ When screwed down, relative to shaft nominal dimension d.

⁴⁾ The load capacities stated are minimum values as the position and direction of load cannot always be precisely defined.

STAR – Linear Sets with Standard Linear Bushings

**Linear Sets, 1067-
open type**

**Linear Sets, 1068-
open type, adjustable**

Structural design

- Precision Housing (spheroidal graphite cast iron)
- Retention by means of locating screw
- Standard Linear Bushings with seals

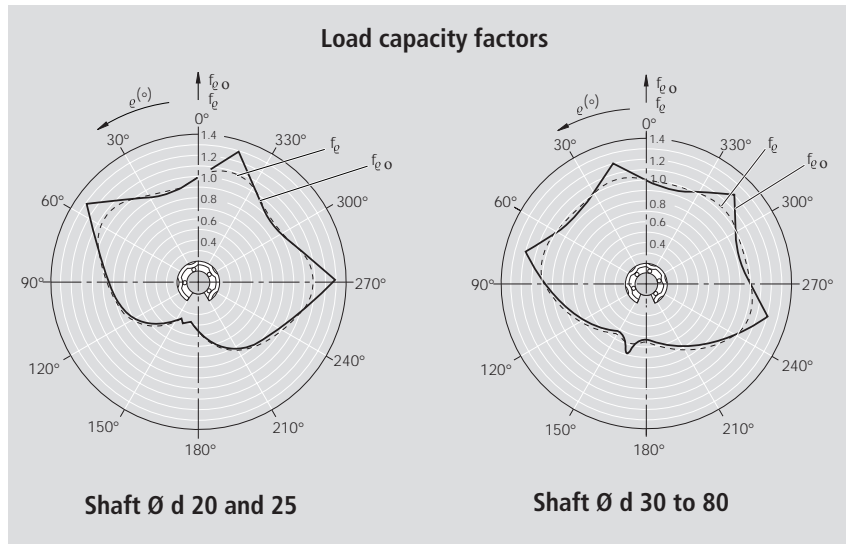

Note:

The diagrams correspond to the mounting position as shown on the photos below and therefore differ from the information given in "Technical Data".

Ordering data



Shaft Ø d (mm)	Part numbers with two seals	Mass (kg)
20	1067-220-00	0.39
25	1067-225-00	0.74
30	1067-230-00	1.14
40	1067-240-00	2.25
50	1067-250-00	3.13
60	1067-260-00	5.78
80	1067-280-00	13.15



Shaft Ø d (mm)	Part numbers with two seals	Mass (kg)
20	1068-220-00	0.38
25	1068-225-00	0.74
30	1068-230-00	1.12
40	1068-240-00	2.20
50	1068-250-00	3.11
60	1068-260-00	5.72
80	1068-280-00	13.09

The figures for dynamic load-carrying capacity have been calculated assuming a nominal travel of 100,000 m.

For a nominal travel of 50,000 m, the 'C' figures in the table must be multiplied by a factor of 1.26.



Dimensions

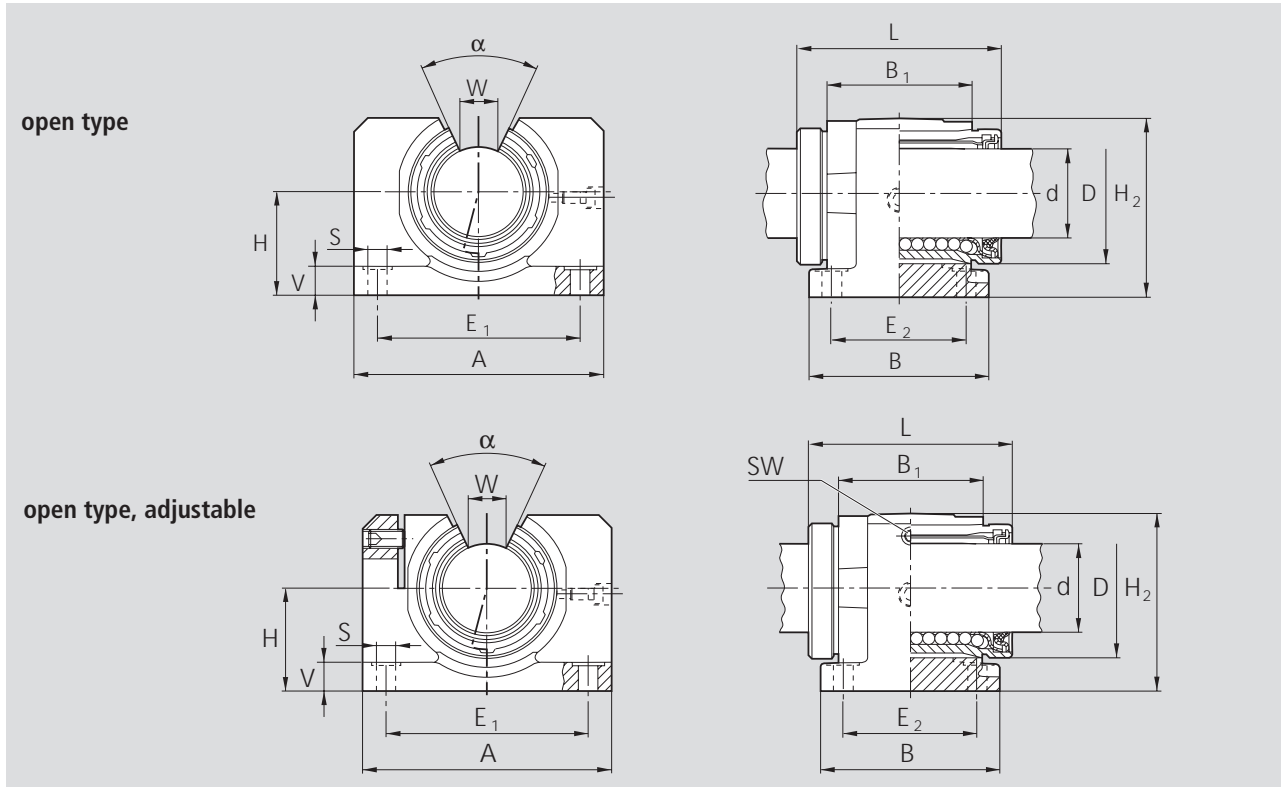

Ø d	Dimensions (mm)													Angle (°)	Radial clearance (µm)		Tolerance (µm) for dimension H ⁴⁾	Load capacities ⁵⁾ (N)	
	D	H	H ₂ ²⁾	L	A ²⁾	B ²⁾	B ₁	E ₁	E ₂	S	V ²⁾	W ³⁾	SW		1067-... with shaft h6	1068-... h7		dyn. C	stat. C ₀
20 ¹⁾	32	25	42	45	60	42	28	45±0.15	32±0.15	4.5	8	10	2.5	60	+36 +4	+42 +6	+5 -19	1280	970
25 ¹⁾	40	30	51	58	74	54	40	60±0.15	40±0.15	5.5	9	12.5	3	60	+38 +4	+44 +6	+5 -19	2270	1750
30	47	35	60	68	84	60	48	68±0.20	45±0.20	6.6	10	12.5	3	50	+38 +4	+44 +6	+5 -19	2890	2390
40	62	45	77	80	108	78	56	86±0.20	58±0.20	9	12	16.8	4	50	+45 +5	+52 +7	+4 -21	5280	4000
50	75	50	88	100	130	70	72	108±0.20	50±0.20	9	14	21	5	50	+45 +5	+52 +7	+8 -25	8470	6900
60	90	60	105	125	160	92	95	132±0.25	65±0.25	11	15	27.2	6	54	+50 +5	+59 +7	+8 -26	11800	9780
80	120	80	140	165	200	122	125	170±0.50	90±0.25	13.5	22	36.3	8	54	+54 +6	+62 +9	+7 -28	21500	17400

1) Contrary to the illustration, the locating screw is on the adjusting side in these sizes.

2) Tolerance to DIN 1685-GTB 15.

3) Lower limit relative to shaft nominal dimension d.

4) When screwed down, relative to shaft nominal dimension d.

5) The load capacities apply when the load is acting along the line $\rho = 0^\circ$.

STAR – Linear Sets with Standard Linear Bushings

Linear Sets, 1073- with side opening

Linear Sets, 1074- with side opening, adjustable

Structural design

- Housing with side opening (spheroidal graphite cast iron)
- Retention by means of grooved taper pin
- Standard Linear Bushing
- External seals

The load carrying capacity of open linear bushings is considerably reduced when the load is applied to the "open" portion of the bushing. The Linear Set with Side Opening has been developed to overcome this disadvantage and to permit selective circumferential positioning of the open linear bushing.

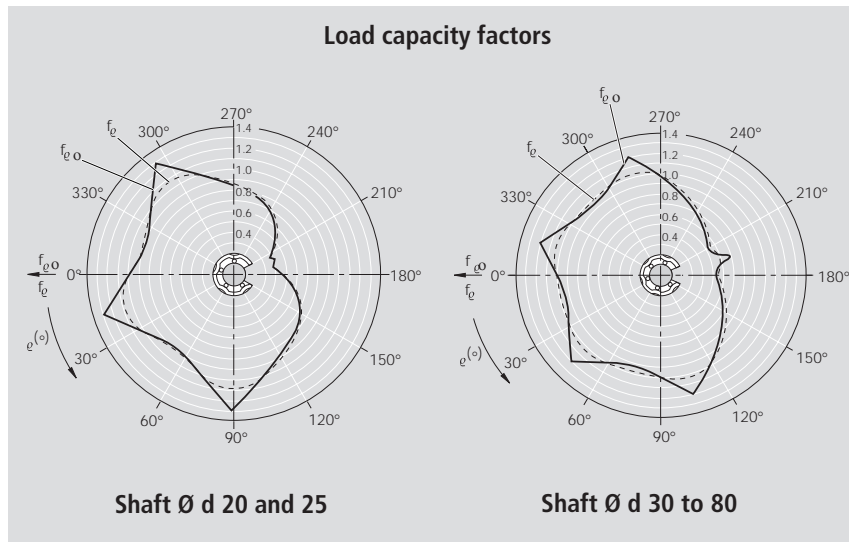

Note:

The diagrams correspond to the mounting position as shown on the photos below and therefore differ from the information given in "Technical Data".

Ordering data



Shaft Ø d (mm)	Part numbers with two seals	Mass (kg)
20	1073-220-00	1.0
25	1073-225-00	1.9
30	1073-230-00	2.8
40	1073-240-00	4.8
50	1073-250-00	8.0



Shaft Ø d (mm)	Part numbers with two seals	Mass (kg)
20	1074-220-00	1.0
25	1074-225-00	1.9
30	1074-230-00	2.8
40	1074-240-00	4.8
50	1074-250-00	8.0

The figures for dynamic load-carrying capacity have been calculated assuming a nominal travel of 100,000 m.

For a nominal travel of 50,000 m, the 'C' figures in the table must be multiplied by a factor of 1.26.



Dimensions

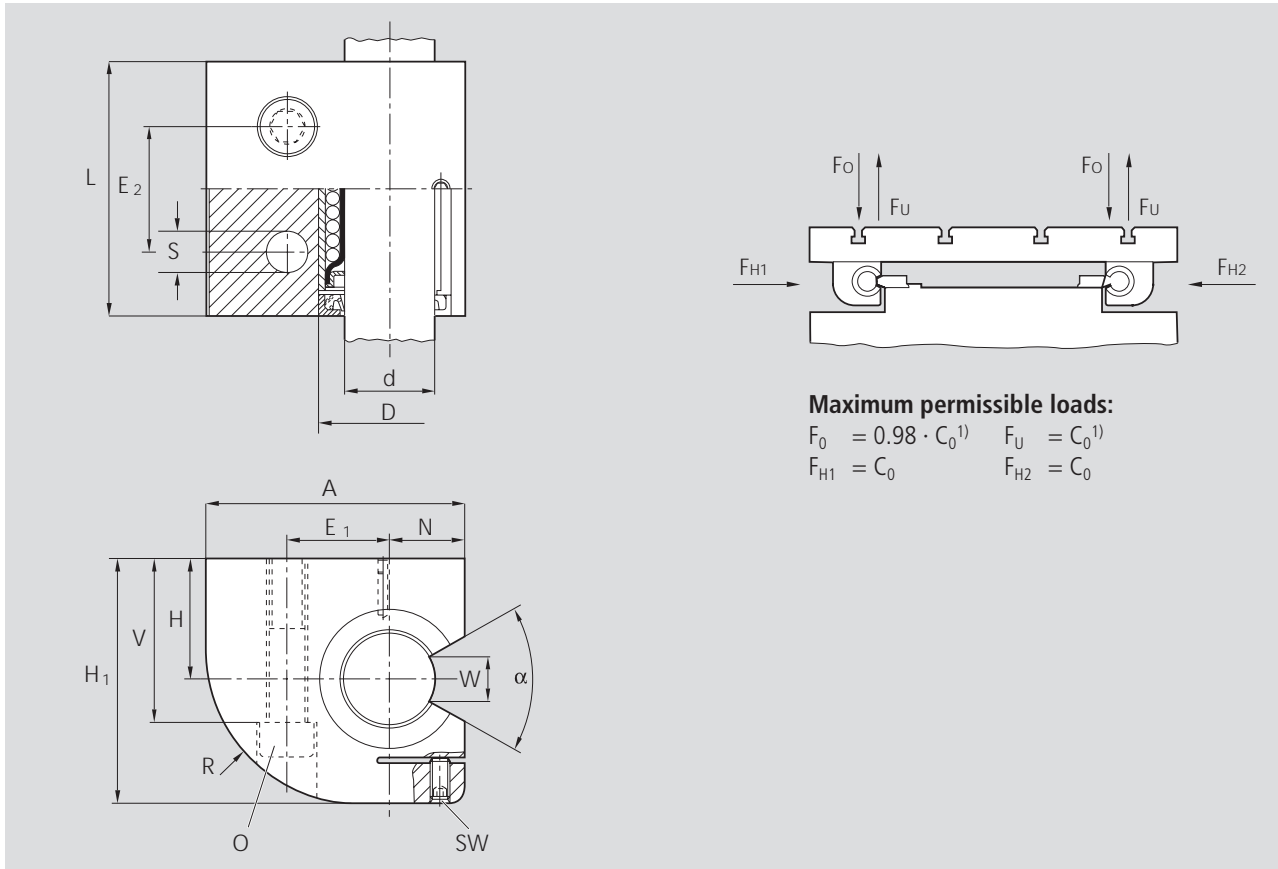

Ø d	Dimensions (mm)													Angle (°)	Radial clearance ⁶⁾ (µm)		Tolerance (µm) for dimension H ⁷⁾	Load capacities ⁸⁾ (N)		
	H	H ₁ ³⁾	L ³⁾	A ³⁾	E ₁	E ₂	N	D	V	S	SW	O ⁴⁾	W ⁵⁾		R ³⁾	a		1073-... with shaft h6	1074-... h7	dyn. C
20 ²⁾	30	60	60	60	22±0.25	30±0.25	17	32	42	9	2.5	M8x60	10	37	60	+36 +4	+42 +6	+5 -19	1280	970
25 ²⁾	35	72	73	75	28±0.25	36±0.25	21	40	50	11	3	M10x70	12.5	45	60	+38 +4	+44 +6	+5 -19	2270	1750
30	40	82	85	86	34±0.50	42±0.50	25	47	55	13.5	3	M12x80	12.5	51	50	+38 +4	+44 +6	+5 -19	2890	2390
40	45	100	97	110	43±0.50	48±0.50	32	62	67	15.5	4	M14x90	16.8	66	50	+45 +5	+52 +7	+4 -21	5280	4000
50	50	115	125	127	50±0.50	62±0.50	38	75	78	17.5	5	M16x110	21	77	50	+45 +5	+52 +7	+8 -25	8470	6900

1) Sizes 20 and 25: $F_0 = 0.85 \cdot C_0$; $F_U = 1.27 \cdot C_0$.

2) In these sizes, the locating screw is on the opposite side to that shown in the illustration.

3) Tolerance to DIN 1685-GTB 16.

4) Hex. socket head cap screws to ISO 4762-8.8.

5) Lower limit relative to shaft nominal dimension d.

6) When screwed down.

7) Relative to shaft nominal dimension d.

8) The load capacities apply when the load is acting along the line $\varrho = 0^\circ$ in the direction shown by the arrows at F_{H1} or F_{H2} .

STAR – Linear Sets with Standard Linear Bushings

Linear Sets, 1081- flanged type

Structural design

- Flanged housing (lamellar graphite cast iron)
- Two retaining rings, plus two spacer rings (steel) for sizes 12 to 40
- Standard Linear Bushings with wiper seals
- The radial clearance is not adjustable

Ordering data



Shaft Ø d (mm)	Part numbers with two seals	Mass (kg)
12	1081-212-00	0.11
16	1081-216-00	0.18
20	1081-220-00	0.33
25	1081-225-00	0.63
30	1081-230-00	1.00
40	1081-240-00	1.90
50	1081-250-00	4.00
60	1081-260-00	7.40
80	1081-280-00	14.70

The figures for dynamic load-carrying capacity have been calculated assuming a nominal travel of 100,000 m. For a nominal travel of 50,000 m, the 'C' figures in the table must be multiplied by a factor of 1.26.

Dimensions

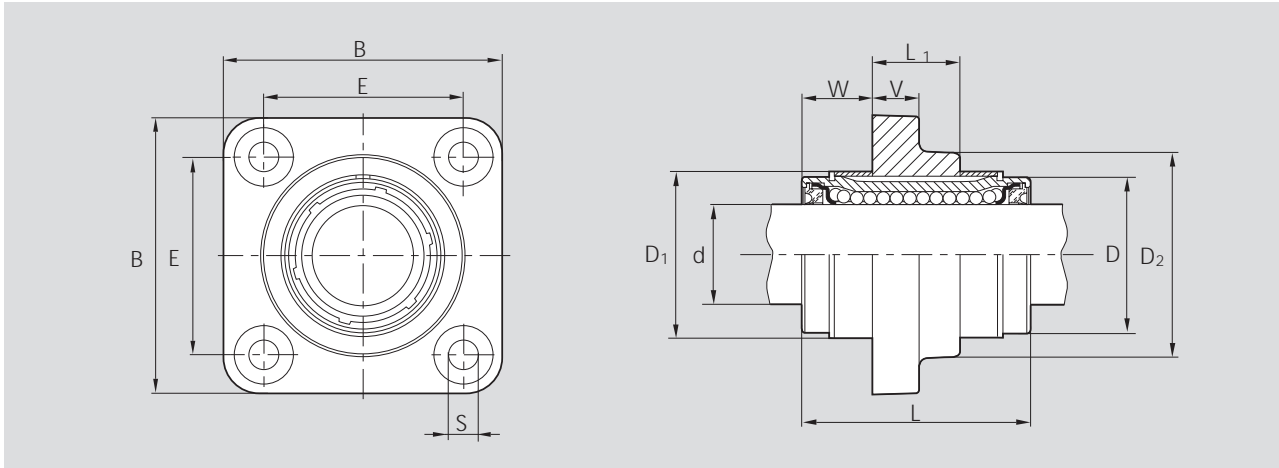

Ø d	Dimensions (mm)										Radial clearance ²⁾ (µm)		Load capacities ³⁾ (N)	
	B ¹⁾	L	L ₁	D	D ₁	D ₂ ¹⁾	E	S	V ¹⁾	W	with shaft h6	h7	dyn. C	stat. C ₀
12	42	32	12	22	24	28	30±0.12	5.5	6	10	+20 +5	+26 +6	420	280
16	50	36	15	26	28.5	34	35±0.12	5.5	8	10.5	+22 +5	+28 +6	580	440
20	60	45	18	32	35	42	42±0.15	6.6	10	13.5	+23 +6	+31 +6	1170	860
25	74	58	23	40	43	54	54±0.15	6.6	12	17.5	+25 +6	+32 +7	2080	1560
30	84	68	26	49.5	52	62	60±0.25	9.0	14	21	+25 +6	+32 +7	2820	2230
40	108	80	36	65	68	80	78±0.25	11	16	22	+30 +7	+38 +8	5170	3810
50	130	100	72	75	81	98	98±0.25	11	18	14	+30 +7	+38 +8	8260	6470
60	160	125	95	90	96	115	120±0.50	14	22	15	+33 +7	+43 +8	11500	9160
80	200	165	125	120	129	150	155±0.50	14	26	20	+37 +8	+47 +9	21000	16300

¹⁾ Tolerance to DIN 1686-GTB 15.

²⁾ Statistically determined from the working bore diameter and shaft tolerances. Taking the Linear Bushing outer diameter and the housing bore into consideration, the radial clearance values for shaft h7 are similar to those given for the Standard Linear Bushing 0610-... in the "h7/H7" column under the heading "Adjustable radial clearance".

³⁾ The load capacities stated are minimum values as the position and direction of load cannot always be precisely defined.

STAR – Super Linear Bushings **A** and **B**

Super Linear Bushings consist of:

- a ball retainer with outer sleeve made of polyamide
- hardened steel segmental load bearing plates with ground ball tracks
- balls of anti-friction bearing steel
- replaceable seals (in the sealed version)
- version **A** with self-alignment feature, i.e. automatic compensation of alignment errors up to 30°
- version **B** without self-alignment

The advantages

- Closed or open types
- Unbeaten smooth running
- The Super Linear Bushing affords the designer a substantially longer travel life than other types of bushings with the same as-installed dimensions.
- High running speed and dynamic load capacity
- High rigidity
- In Super Linear Bushing Version **A** there is no reduction in load capacity due to bushing edge pressure.
- With internal or separate seals
- Super Linear Bushings **A** and **B** have the same outer dimensions as and are therefore interchangeable with Super Linear Bushings **HD** and **SD** as well as Standard Linear Bushings (please refer to the technical data for the respective versions).
- Fast acceleration and high running speed due to
 - precision guidance of the balls in the ball tracks
 - wear-resistant ball retainer

Super Linear Bushings **A** automatically compensate for alignment errors of up to 30°. No reduction in load-carrying capacity due to pressure between bushing edge and shaft. The outer surface of the steel load bearing plates is designed with the central portion slightly thicker than its ends. The central portion serves as a rocking fulcrum to compensate automatically for any slight misalignment between shaft and housing bore.

This self-alignment feature assures:

- smooth entry and exit of the balls into and out of the load carrying area,
- uniform load distribution over the entire row of balls.

and results in:

- extremely smooth operation
- very high load-carrying capacity
- extremely long service life

Alignment errors can be caused by:

- inaccurate machining
- mounting errors
- shaft deflection

The self-alignment feature is not able to compensate for poor parallelism between the two shafts of a carriage assembly.



Closed type
(Super )



Open type
(Super )



STAR – Super Linear Bushings **A** and **B**

Technical Data

Please observe the general technical principles and mounting instructions at the beginning of this catalog as well as the additional technical data given below.

Sealing

Super Linear Bushings are available with internal or with separate wiper-type seals. The use of separate seals is advisable in applications involving a high risk of foreign-body contamination. In very dirty environments additional sealing may be necessary (e.g. bellows-type dust boots or telescoping sleeves).

Open type Super Linear Bushings can also be supplied fully sealed (with seal strip). It should be noted that the friction values for the fully sealed version will be higher.

Friction

Very low friction due to the rolling friction principle. Extremely low breakaway forces. The friction μ of unsealed Super Linear Bushings using oil as a lubricant lies between 0.001 and 0.0025.

The friction is lowest under high load. It may, however, be greater than the stated value when only a slight load is applied.

For Super Linear Bushings fitted at both ends with internal wiper seals and not subject to radial loading, the frictional drag (see table below) depends on the speed and the type of lubrication.

Shaft Ø d (mm)	Closed and open Super Linear Bushings with internal seals		Open Super Linear Bushings fully sealed	
	Breakaway force ¹⁾ (N) approx.	Frictional drag ¹⁾ (N) approx.	Breakaway force (N) approx.	Frictional drag (N) approx.
10	1.5	0.8	–	–
12	2	1	6	3
16	2.5	1.3	9	4
20	3	1.5	10	5
25	4.5	2	14	6
30	6	2.5	18	8
40	8	3	24	10
50	10	4	30	12

¹⁾ For separate wiper seals, the values must be multiplied by a factor of 1.5.

Velocity

$$v_{\max}^{1)} = 3 \text{ m/s}$$

¹⁾ Velocities up to 5 m/s are possible, though the service life will be restricted due to the increased wear on the plastic parts. Units have been known to travel 5 to 10 x 10⁶ m without failure under test conditions.

Acceleration

$$a_{\max} = 150 \text{ m/s}^2$$

Operating temperature

up to 100 °C

Direction of load and its influence on the load capacity of closed Super Linear Bushings

The stated load capacities are valid for installation in "min" position and should be taken as the basis for calculation.

In applications where the direction of load is exactly known and where the Super Linear Bushings can be mounted in the "max" position, the load capacity rating must be multiplied by the factors f_{max} (dynamic load capacity C) or f_{0max} (static load capacity C_0).

Shaft Ø d (mm)	Load capacity factors	
	f_{max}	f_{0max}
10, 12, 16	1.19	1.46
20, 25, 30, 40, 50	1.06	1.28



Direction of load and its influence on the load capacity of open Super Linear Bushings

The load capacities C and C_0 apply only when the load is acting along the line $\varrho = 0^\circ$. If the load is acting in any other direction, these load capacities must be multiplied by the factor f_ϱ (dynamic load capacity C) or $f_{\varrho 0}$ (static load capacity C_0).

A reduction in load capacity can be eliminated by selective circumferential positioning of the Super Linear Bushing (see Linear Set with Side Opening).

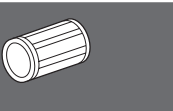
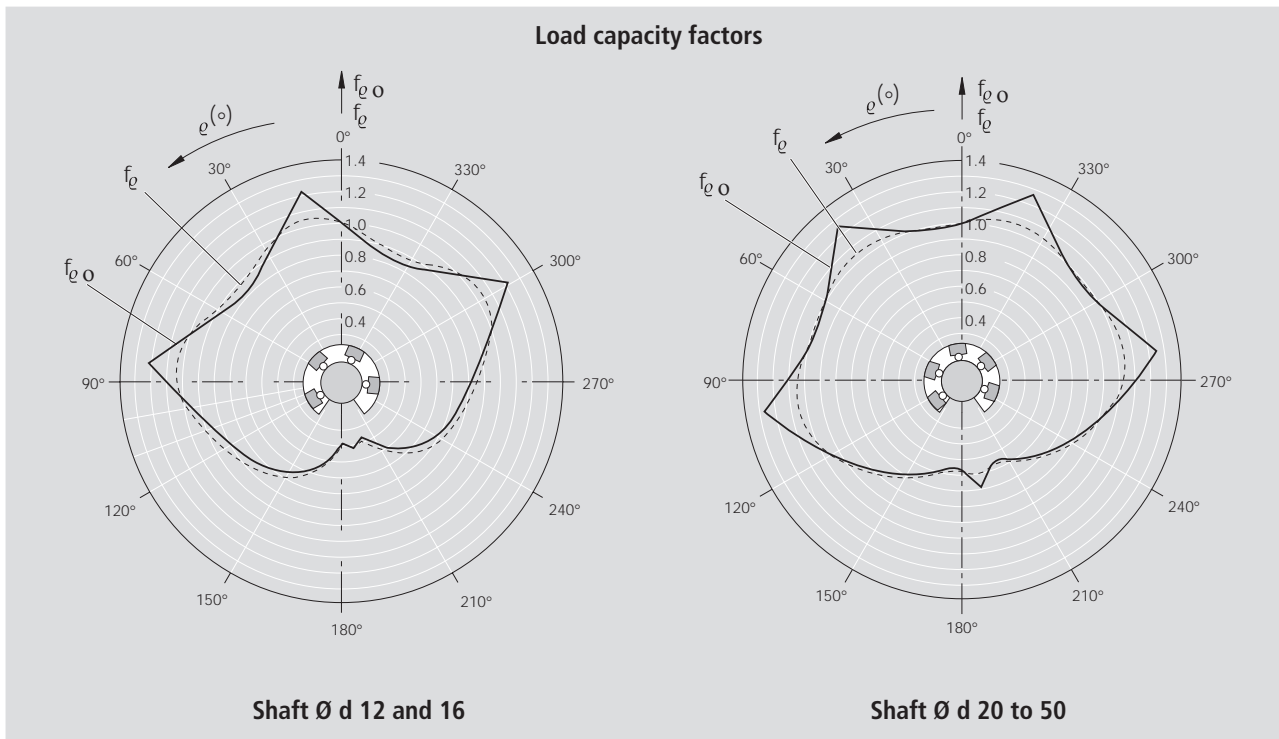

STAR – Super Linear Bushings **A** and **B**

Technical Data

Reduced load capacity in short-stroke applications

In short-stroke applications, the service life of the shafts is shorter than that of the Super Linear Bushings.

For this reason, the load capacities C listed in the tables must be multiplied by the factor f_w .

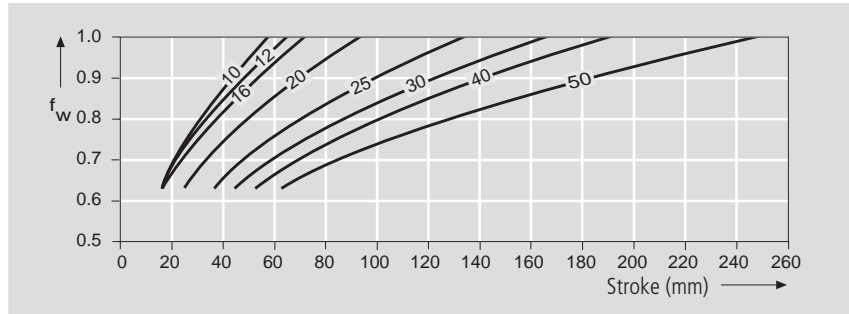

Reduced load capacity at high loads

If the load acting on Super Linear Bushing **A** is $F > 0.5 \times C$, there will be a reduction in the dynamic load capacity C . At load $F = C_0$, the load capacity C has to be multiplied by the load factor $f_F = 0.93$.

Self-alignment feature in Super Linear Bushing **A**

The self-alignment feature together with the ground-quality finish of the ball tracks result in extremely smooth operation. The running diagrams below show a comparison with a conventional linear bearing for a load of 800 N and an alignment error of about 8' (due to shaft deflection).

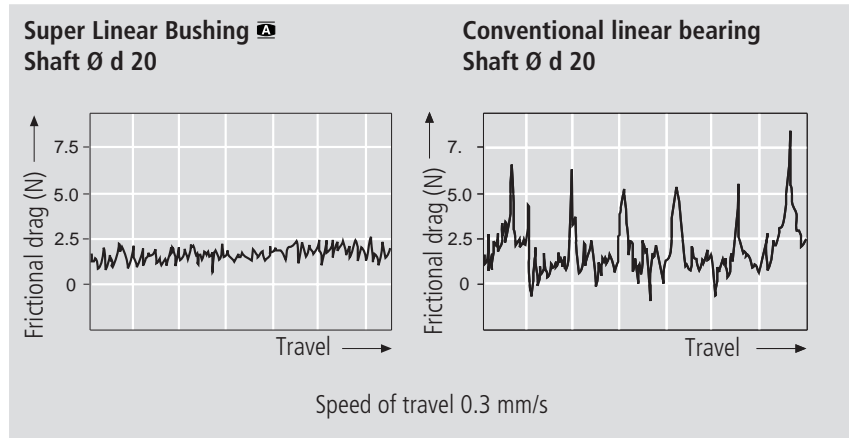
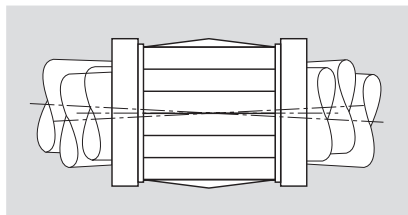

When this type is used, the self-alignment feature requires **two** Super Linear Bushings to be mounted on at least one of the two shafts of the assembly.

Operation under difficult conditions

For applications involving water-base coolants/lubricants, we recommend the use of the following linear bushing models:

- Super Linear Bushings **1B** and **5B**
- Standard Linear Bushings

In permanently humid or wet environments (water vapor, condensation), we recommend the use of the following corrosion-resistant linear bushing models:

- Segmental Linear Bushings or
- Compact Linear Bushings

with steel parts made of corrosion-resistant steel to DIN 17230 / EN 10088.

Notes for Mounting

Radial clearance

The radial clearance values given in the tables have been obtained by statistical methods and are representative of the clearances to be expected in actual practice.

Adjusting the radial clearance

The radial clearance is adjustable in all types of Super Linear Bushings. If an application calls for zero clearance, the radial clearance must be reduced by means of an adjusting screw in the bushing housing (see also Linear Sets) until a slight resistance is felt when the shaft is turned. In applications subject to vibration, the adjusting screw should be suitably secured against working loose once the desired clearance has been established.

Preload

If negative clearance (preload) is required, we recommend that zero clearance should be established as described above using a dummy shaft whose diameter is smaller by the amount of the desired preload than the actual guide shaft on which the linear bushing is to run.

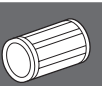

STAR – Super Linear Bushings **A** and **B** Customer-Built Housing

Lube groove and lube hole for
Super Linear Bushings **A**, **B**,
closed type – with external seals

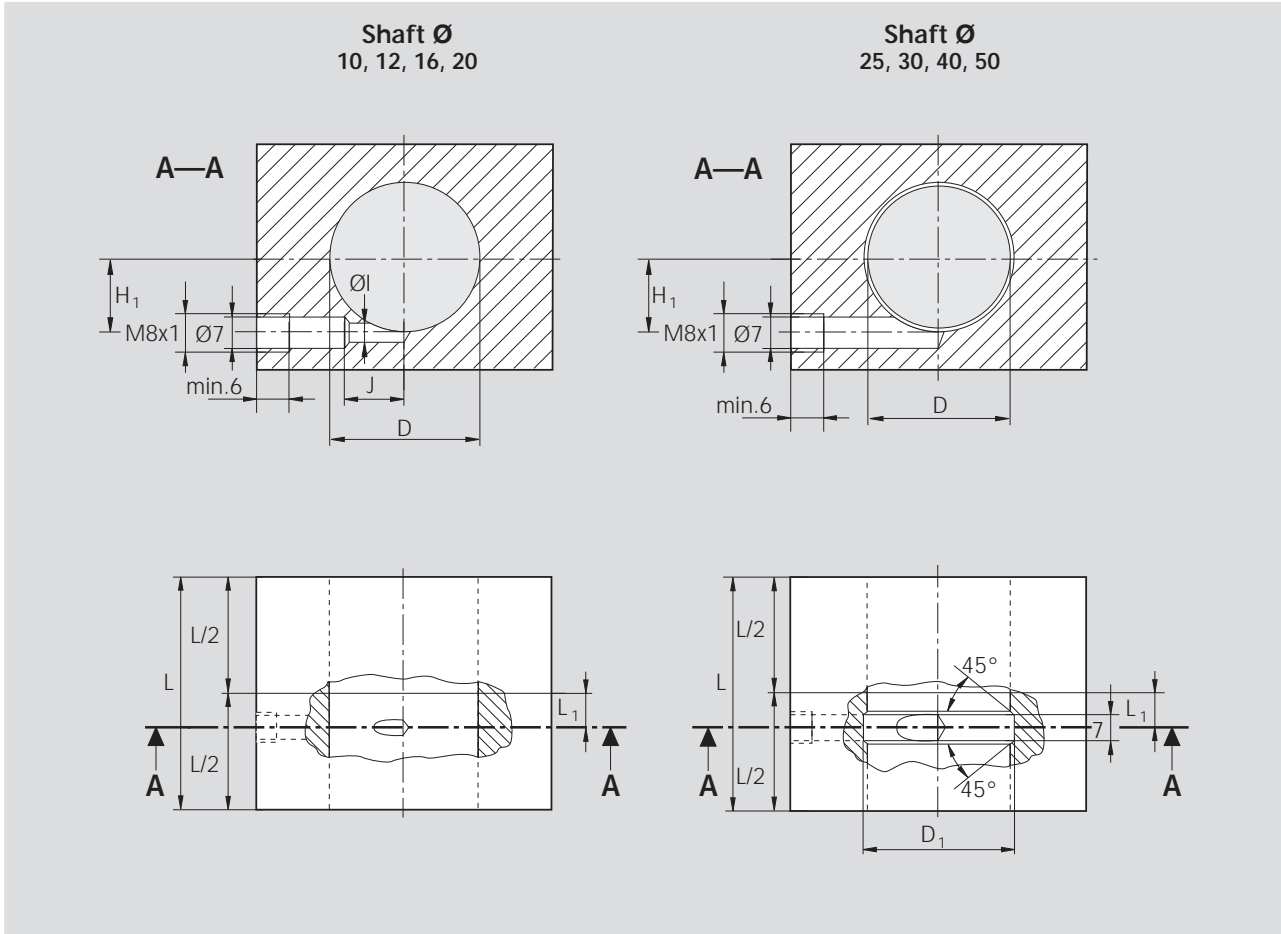

The lube channels shown in the illustration have been designed for grease lubricants.

Linear Bushing with separate seals Part numbers		Shaft diameter d (mm)	Dimensions (mm)						
A	B		L ₁	H ₁	L (min)	D	D ₁	l	J
0670-210-00	0672-210-00	10	7.5	6	36	19	–	3	11.5
0670-212-00	0672-212-00	12	9	8	39	22	–	5	13
0670-216-00	0672-216-00	16	10	12	43	26	–	5	18
0670-220-00	0672-220-00	20	13.5	15	54	32	–	2	15.5
0670-225-00	0672-225-00	25	18.5	20	67	40	42	–	–
0670-230-00	0672-230-00	30	23.5	23.5	79	47	49	–	–
0670-240-00	0672-240-00	40	27.5	31	91	62	66	–	–
0670-250-00	0672-250-00	50	34.5	37.5	113	75	79	–	–

**Lube groove and lube hole for
Super Linear Bushings **A**, **B**,
open type – with external seals**

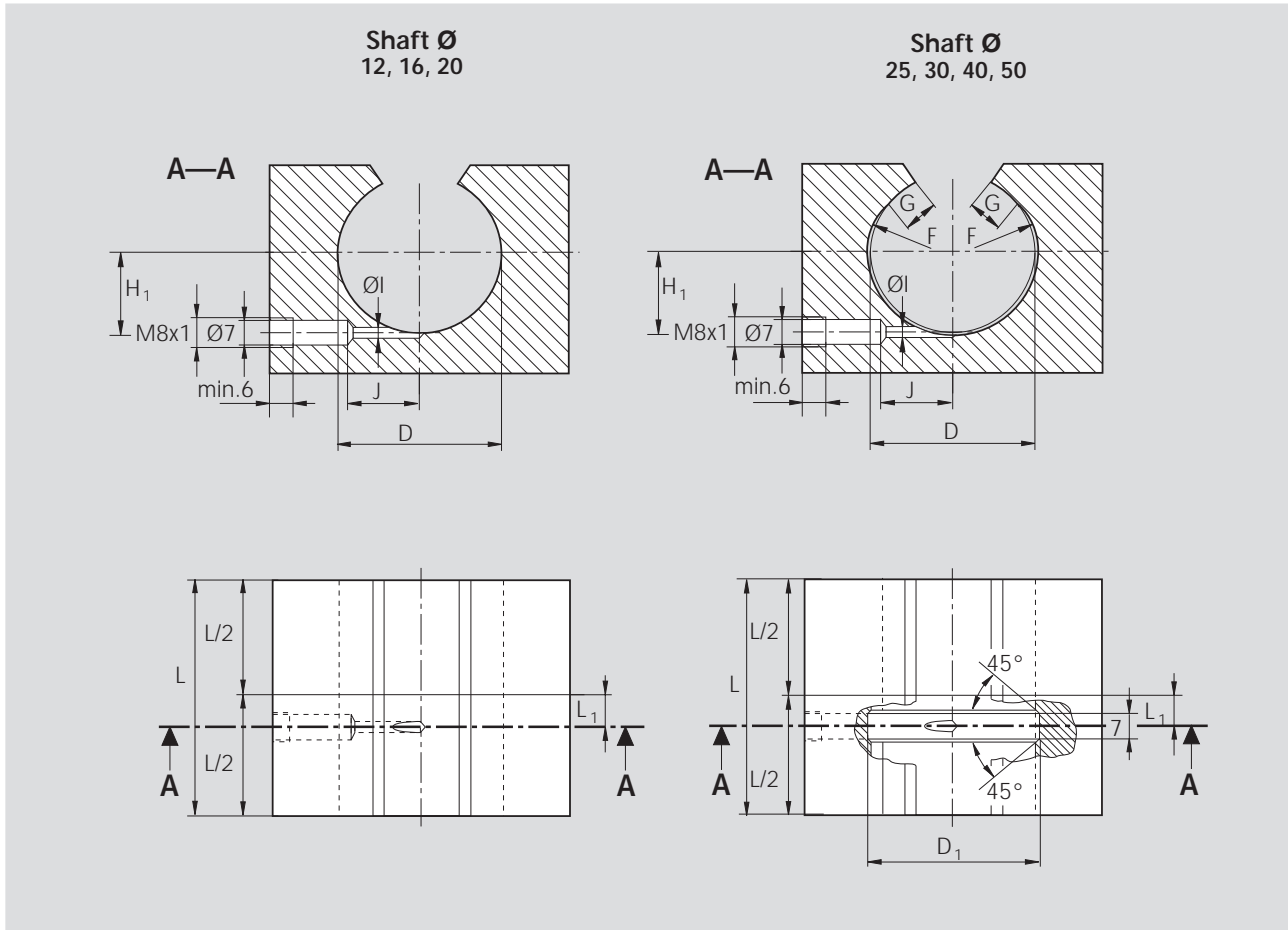

The lube channels shown in the illustration have been designed for grease lubricants. Seals must be secured axially.

Linear Bushing with separate seals Part numbers		Shaft diameter d (mm)	Dimensions (mm)								
A	B		L_1	H_1	L (min)	D	D_1	F	G	I	J
0671-212-00	0673-212-00	12	9	8	39	22	-	-	-	2	13
0671-216-00	0673-216-00	16	10	12	43	26	-	-	-	2	14
0671-220-00	0673-220-00	20	13.5	15	54	32	-	-	-	2	16
0671-225-00	0673-225-00	25	18.5	20	67	40	42	R 15	4	7	-
0671-230-00	0673-230-00	30	23.5	23.5	79	47	49	R 18	4.5	7	-
0671-240-00	0673-240-00	40	27.5	31	91	62	66	R 23	6	7	-
0671-250-00	0673-250-00	50	34.5	37.5	113	75	79	R 28	7	4	30

STAR – Super Linear Bushings **A** and **B** Customer-Built Housings

Retention

Super Linear Bushings

closed type

- Retaining rings
- Metal case
- Seal with metal case
- Special arrangement

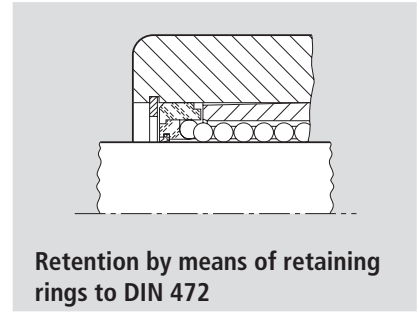
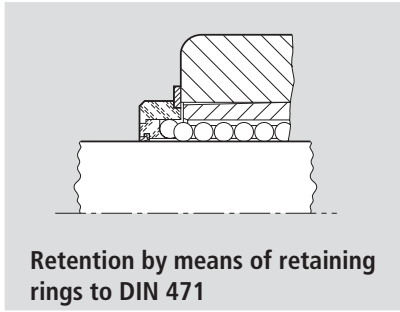

Shaft Ø d (mm)	Retaining rings DIN 471		Retaining rings DIN 472	
	Part numbers	Dimensions (mm)	Part numbers	Dimensions (mm)
10	8410-763-00	19 x 1.2	8410-221-00	19 x 1
12	8410-714-00	22 x 1.2	8410-209-00	22 x 1
16	8410-715-00	27 x 1.2 ¹⁾	8410-210-00	26 x 1.2
20	8410-716-00	33 x 1.5 ¹⁾	8410-211-00	32 x 1.2
25	8410-717-00	42 x 1.75	8410-212-00	40 x 1.75
30	8410-718-00	48 x 1.75	8410-213-00	47 x 1.75
40	8410-719-00	62 x 2	8410-214-00	62 x 2
50	8410-720-00	75 x 2.5	8410-215-00	75 x 2.5

¹⁾ not to DIN 471

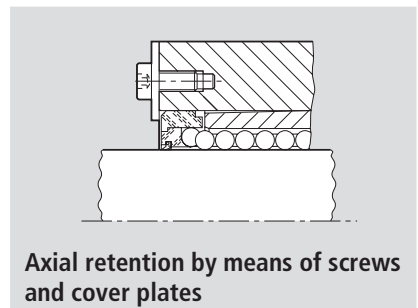
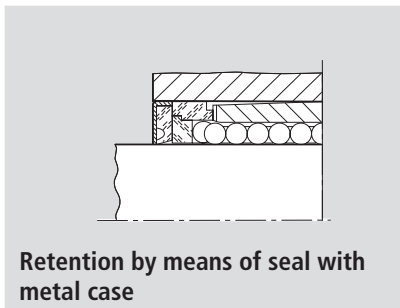
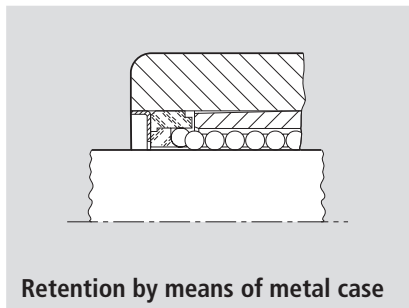

Separate seals

Seal with metal case (closed type)

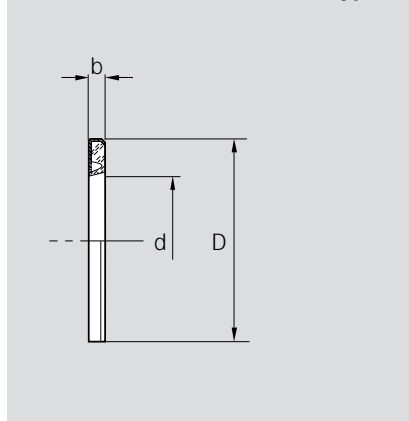

Materials: elastomer seal, steel case

Shaft Ø d (mm)	Dimensions (mm)		Part numbers	
	D ²⁾	b +0.3	seal with metal case	metal case
10	19	3	1331-610-00	0901-184-00
12	22	3	1331-612-00	0901-074-00
16	26	3	1331-616-00	0901-075-00
20	32	4	1331-620-00	0901-076-00
25	40	4	1331-625-00	0901-077-00
30	47	5	1331-630-00	0901-078-00
40	62	5	1331-640-00	0901-079-00
50	75	6	1331-650-00	0901-115-00

²⁾ The outside diameter D has been manufactured with an oversize of approx. 0.1 mm. No additional retention required.

Super Linear Bushings open type

- axial and rotary retention by means of grooved taper pins

Notes for mounting:

Open-type Super Linear Bushings are delivered with a ready-made locating pin hole. This hole is marked with a "☉" from shaft diameter 25 upwards.

The grooved locating pin must be driven in to the depth shown in the illustrations, as applicable, at the time of mounting.

The outer diameter of the Super Linear Bushing must then be reduced until the bushing can be slipped past the pin. When the linear bushing is aligned in the housing bore, the taper pin will engage in the retaining hole.

Size of the hole through housing for grooved locating pin:

Shaft diameters 12 to 40:

Ø 3.0 H11

(Grooved pin ISO 8744-3x ...-St)

Shaft diameter 50:

Ø 5.0 H11

(Grooved pin ISO 8744-5x ...-SA)

Super Linear Bushings for shaft diameters 25 to 50 are provided with 2 locating pin holes.

The second locating pin hole (Ø 3.5 for shaft diameters 25, 30 and 40 and Ø 4.5 for shaft diameter 50) is provided as an alternative means for retention of the Linear Bushing.

The original locating pin holes are marked with a star "☉" (see illustration).

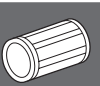
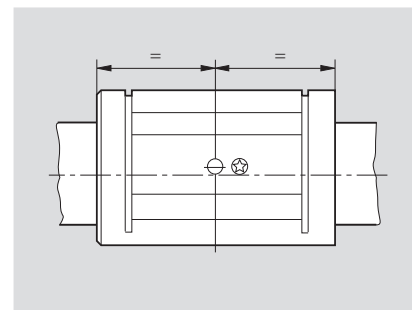
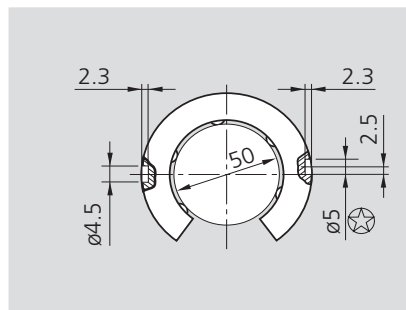
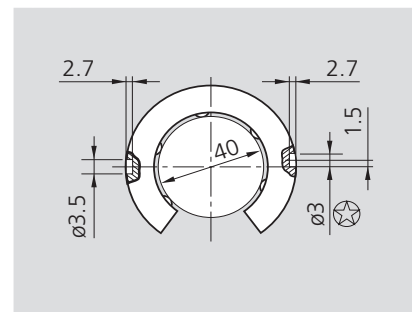
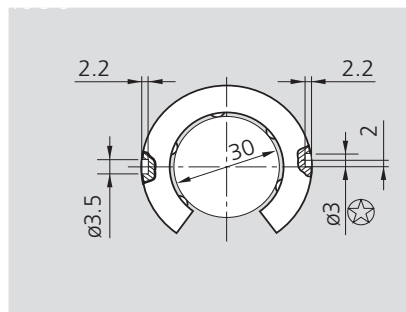
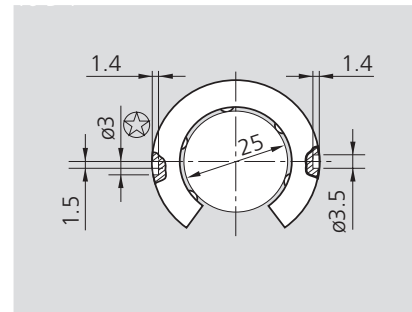
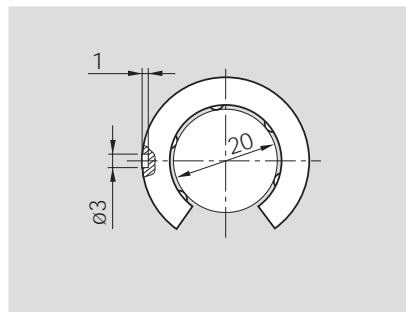
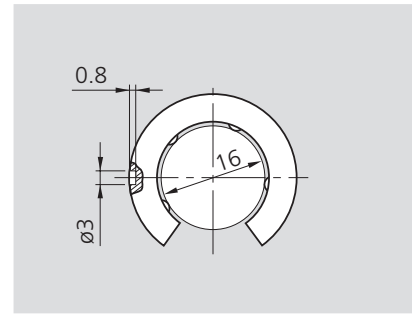
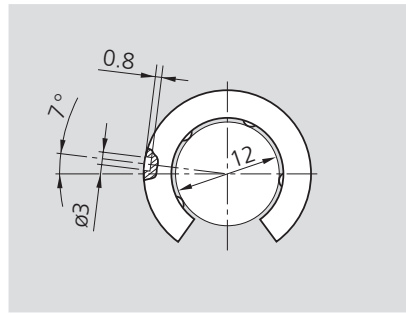

Grooved taper pin

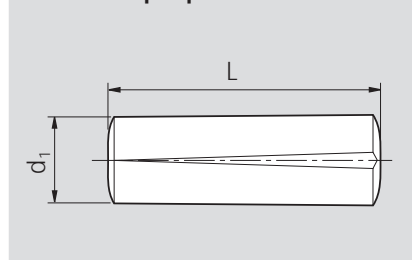

Shaft Ø d (mm)	Dimensions (mm)		Mounting hole for grooved taper pin (mm)	Part numbers
	d ₁	L		
12 ... 40	3	5.2	Ø 3 H11	8425-012-00
	3	8.2		8425-013-00
	3	10.2		8425-014-00
	3	14.2		8425-015-00
50	5	20.4	Ø 5 H11	8425-016-00
	5	14		8425-017-00

STAR – Super Linear Bushings **A** and **B** Customer-Built Housings

- axial and rotary retention by means of locating screw

Points to note when mounting:
Open type Standard Linear Bushings have been provided with the necessary retention hole. This hole is marked with a "⊗" from shaft diameter 25 upwards.

On installation, the retention hole of the Linear Bushing must be aligned with the tapped hole in the housing. The screw is then inserted, screwed down to the specified depth and tightened to the specified torque.

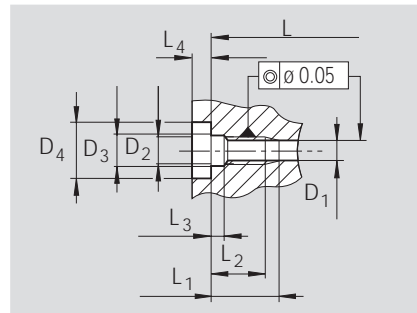
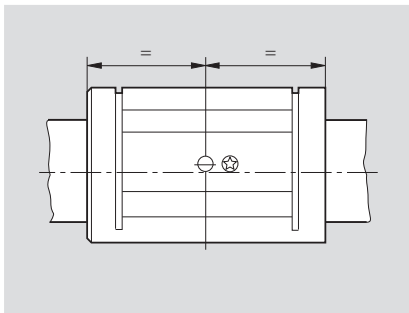
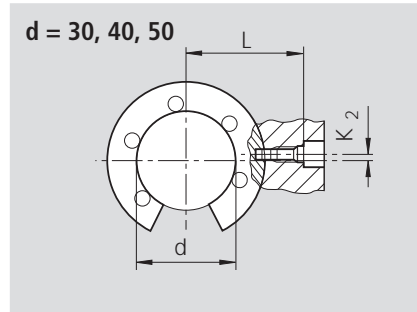
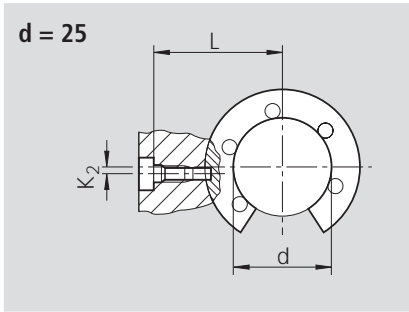
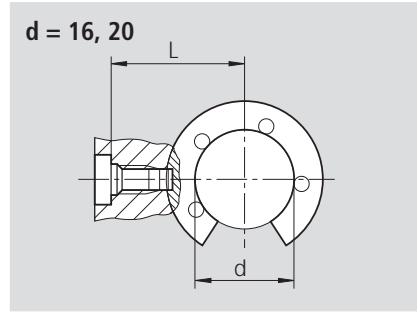
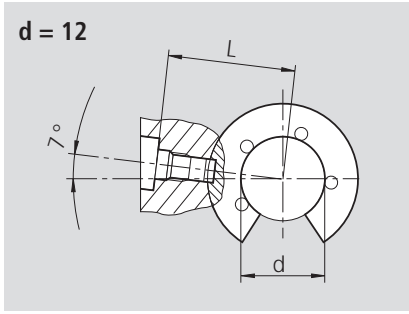

Shaft Ø d (mm)	Dimensions (mm)										Locating screw	
	L	K ₂	L ₁	L ₂	L ₃	L ₄	D ₁	D ₂	D ₃	D ₄	Part numbers	Tightening torque (Nm)
12	18.8 _{-0.1}	–	7.2 _{max}	5.2	1.3	2.5	3.1	M4	4.5	8	8429-008-01	1.9
16	22.5 _{-0.1}	0	8.5 ^{+0.2}	6.5	1.3	2.5	3.1	M4	4.5	8	8429-009-01	1.9
20	25.5 _{-0.1}	0	8.5 ^{+0.2}	6.5	1.3	2.5	3.1	M4	4.5	8	8429-009-01	1.9
25	33.05 _{-0.1}	1.5	10 ^{+0.2}	8	2	3.2	3.1	M4	4.5	8	8427-009-09	1.9
30	36 _{-0.15}	2	10 ^{+0.2}	8	2	3.2	3.1	M4	4.5	8	8427-009-09	1.9
40	42.9 _{-0.15}	1.5	10 ^{+0.2}	8	2	3.2	3.1	M4	4.5	8	8427-009-09	1.9
50	58.5 _{-0.2}	2.5	17.5 ^{+0.5}	13.5	3.7	6	5.1	M8	9	15	8427-005-09	16

Locating screws

for shaft \varnothing 12, 16, 20

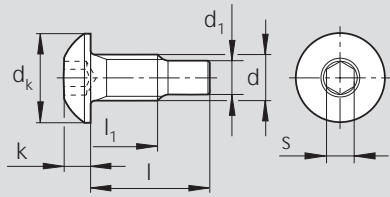

for shaft \varnothing 25, 30, 40, 50

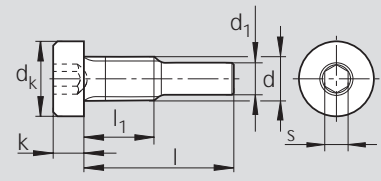

Shaft \varnothing d (mm)	Part numbers	Dimensions (mm)							Tightening torque (Nm)
		d	d _k	d ₁	l	l ₁	k	s	
12	8429-008-01	M4	7.6	3	8.45	4.5	2.2	2.5	1.9
16, 20	8429-009-01	M4	7.6	3	10.15	5.7	2.2	2.5	1.9
25, 30, 40	8427-009-09	M4	7	3	14.1	6.5	2.8	2.5	1.9
50	8427-005-09	M8	13	5	22.8	12.5	5	5	16

The locating screws are of the self-locking type.

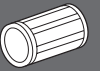

Separate seals

seal with metal case (open type)

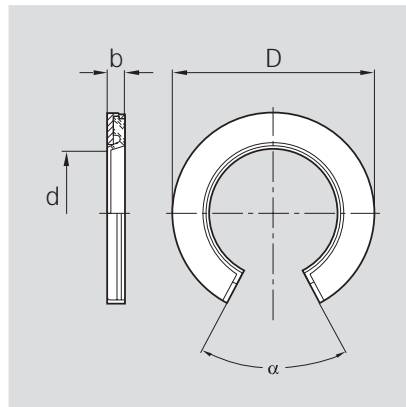

Shaft \varnothing d (mm)	Dimensions (mm)		Angle ($^{\circ}$) $\alpha^{2)}$	Part numbers Seal with metal case
	D ¹⁾	b +0.1 -0.2		
12	22	3	66	1331-712-50
16	26	3	68	1331-716-50
20	32	4	55	1331-720-50
25	40	4	57	1331-725-50
30	47	5	57	1331-730-50
40	62	5	56	1331-740-50
50	75	6	54	1331-750-50

¹⁾ Outside diameter D is about 0.3 mm oversize. No retaining elements required. Additional means of retention recommended for applications subject to vibration or high acceleration rates.

²⁾ Lower limit, measured when mounted in a bore of nominal diameter D.

STAR – Super Linear Bushings **A** with self-alignment feature

**Super Linear Bushings, 0670-
closed type**

**Super Linear Bushings, 0671-
open type**

Structural design

- Ball retainer with outer sleeve made of polyamide
- Hardened steel segmental load bearing plates with ground ball tracks
- Balls of anti-friction bearing steel
- Automatic compensation of alignment errors up to 30'
- Without seals
- With internal/separate seals

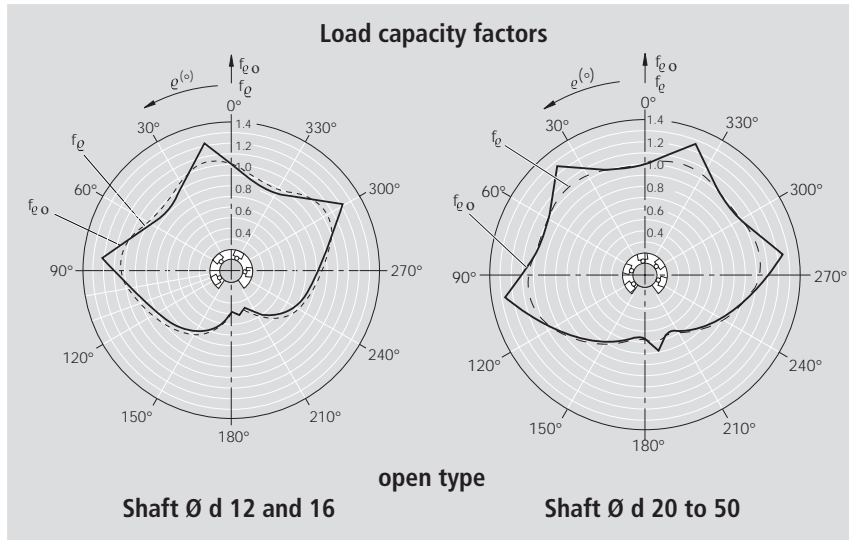

Ordering data

closed type



Shaft Ø d (mm)	Part numbers			Mass (kg)
	without seals	with two internal seals	with two separate seals ¹⁾	
10	0670-010-00	0670-210-40	0670-210-00	0.017
12	0670-012-00	0670-212-40	0670-212-00	0.023
16	0670-016-00	0670-216-40	0670-216-00	0.028
20	0670-020-00	0670-220-40	0670-220-00	0.061
25	0670-025-00	0670-225-40	0670-225-00	0.122
30	0670-030-00	0670-230-40	0670-230-00	0.185
40	0670-040-00	0670-240-40	0670-240-00	0.360
50	0670-050-00	0670-250-40	0670-250-00	0.580

With one internal seal: 0670-1..-40

open type



Shaft Ø d (mm)	Part numbers				Mass (kg)
	without seals	with two internal seals	with two internal seals and seal strip	with two separate seals ¹⁾	
12	0671-012-00	0671-212-40	0671-212-45	0671-212-00	0.018
16	0671-016-00	0671-216-40	0671-216-45	0671-216-00	0.022
20	0671-020-00	0671-220-40	0671-220-45	0671-220-00	0.051
25	0671-025-00	0671-225-40	0671-225-45	0671-225-00	0.102
30	0671-030-00	0671-230-40	0671-230-45	0671-230-00	0.155
40	0671-040-00	0671-240-40	0671-240-45	0671-240-00	0.300
50	0671-050-00	0671-250-40	0671-250-45	0671-250-00	0.480

With one internal seal: 0671-1..-40

¹⁾ For dimension, see section on "Customer-Built Housings"

The figures for dynamic load-carrying capacity have been calculated assuming a nominal travel of 100,000 m. For a nominal travel of 50,000 m, the 'C' figures in the table must be multiplied by a factor of 1.26.

Dimensions

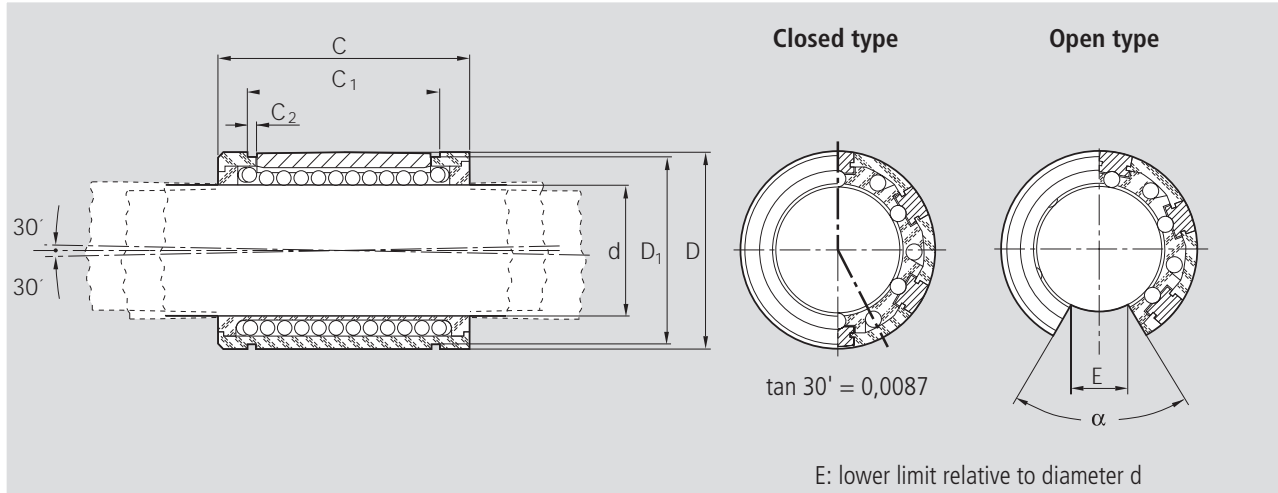

Closed type

Ø d	Ø D	Dimensions (mm)				No. of ball circuits	Radial clearance (µm)				Load capacities ¹⁾ (N)	
		C h13	C ₁ H13	C ₂	D ₁		shaft/bore				dyn. C	stat. C ₀
						h7/H7	h7/JS7	h6/JS6	h6/K6			
10	19	29	21.6	1.3	18	+40 +11	+30 0	+23 +1	+18 -3	550	330	
12	22	32	22.6	1.3	21	+43 +12	+33 +1	+25 +2	+21 -3	770	420	
16	26	36	24.6	1.3	24.9	+43 +12	+33 +1	+25 +2	+21 -3	940	530	
20	32	45	31.2	1.6	30.5	+49 +13	+37 0	+28 +1	+23 -4	1860	1050	
25	40	58	43.7	1.85	38.5	+49 +13	+37 0	+28 +1	+23 -4	3640	2180	
30	47	68	51.7	1.85	44.5	+49 +13	+37 0	+28 +1	+23 -4	4420	2790	
40	62	80	60.3	2.15	58.5	+57 +14	+42 -1	+31 +1	+25 -4	7590	4350	
50	75	100	77.3	2.65	71.5	+57 +14	+42 -1	+31 +1	+25 -4	11100	6470	

Open type

Ø d	Ø D	Dimensions (mm)					Angle (°) α	No. of ball circuits	Radial clearance (µm)				Load capacities ²⁾ (N)	
		C h13	C ₁ H13	C ₂	D ₁	E			shaft/bore				dyn. C	stat. C ₀
								h7/H7	h7/JS7	h6/JS6	h6/K6			
12	22	32	22.6	1.3	21	6.5	66	4	+43 +12	+33 +1	+25 +2	+21 -3	880	510
16	26	36	24.6	1.3	24.9	9	68	4	+43 +12	+33 +1	+25 +2	+21 -3	1060	630
20	32	45	31.2	1.6	30.5	9	55	5	+49 +13	+37 0	+28 +1	+23 -4	1880	1070
25	40	58	43.7	1.85	38.5	11.5	57	5	+49 +13	+37 0	+28 +1	+23 -4	3680	2250
30	47	68	51.7	1.85	44.5	14	57	5	+49 +13	+37 0	+28 +1	+23 -4	4470	2880
40	62	80	60.3	2.15	58.5	19.5	56	5	+57 +14	+42 -1	+31 +1	+25 -4	7680	4480
50	75	100	77.3	2.65	71.5	22.5	54	5	+57 +14	+42 -1	+31 +1	+25 -4	11200	6620

¹⁾ The load capacities stated are minimum values as the position and direction of load cannot always be precisely defined.

²⁾ The stated load capacities apply when the load is acting along the line $\varrho = 0^\circ$.

STAR – Super Linear Bushings **B** without self-alignment feature

Super Linear Bushings, 0672-
closed type

Super Linear Bushings, 0673-
open type

Structural design

- Ball retainer with outer sleeve made of polyamide
- Hardened steel segmental load bearing plates with ground ball tracks
- Balls of anti-friction bearing steel
- Without seals
- With internal/separate seals

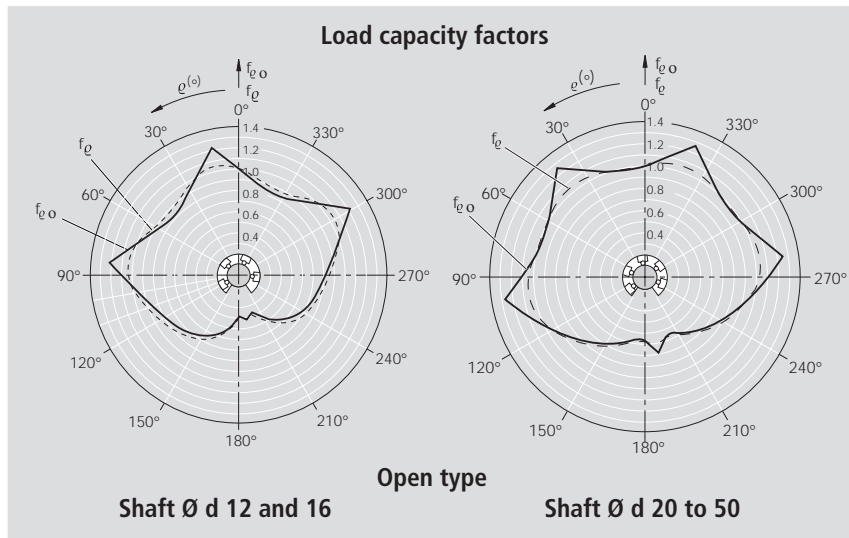

Ordering data



Shaft Ø d (mm)	Part numbers			Mass (kg)
	without seals	with two internal seals	with two separate seals ¹⁾	
10	0672-010-00	0672-210-40	0672-210-00	0.017
12	0672-012-00	0672-212-40	0672-212-00	0.023
16	0672-016-00	0672-216-40	0672-216-00	0.028
20	0672-020-00	0672-220-40	0672-220-00	0.061
25	0672-025-00	0672-225-40	0672-225-00	0.122
30	0672-030-00	0672-230-40	0672-230-00	0.185
40	0672-040-00	0672-240-40	0672-240-00	0.360
50	0672-050-00	0672-250-40	0672-250-00	0.580

With one internal seal: 0672-1...-40



Shaft Ø d (mm)	Part numbers				Mass (kg)
	without seals	with two internal seals	with two internal seals and seal strip	with two separate seals ¹⁾	
12	0673-012-00	0673-212-40	0673-212-45	0673-212-00	0.018
16	0673-016-00	0673-216-40	0673-216-45	0673-216-00	0.022
20	0673-020-00	0673-220-40	0673-220-45	0673-220-00	0.051
25	0673-025-00	0673-225-40	0673-225-45	0673-225-00	0.102
30	0673-030-00	0673-230-40	0673-230-45	0673-230-00	0.155
40	0673-040-00	0673-240-40	0673-240-45	0673-240-00	0.300
50	0673-050-00	0673-250-40	0673-250-45	0673-250-00	0.480

With one internal seal: 0673-1...-40

¹⁾ For dimension, see section on "Customer-Built Housings"

The figures for dynamic load-carrying capacity have been calculated assuming a nominal travel of 100,000 m. For a nominal travel of 50,000 m, the 'C' figures in the table must be multiplied by a factor of 1.26.

Dimensions

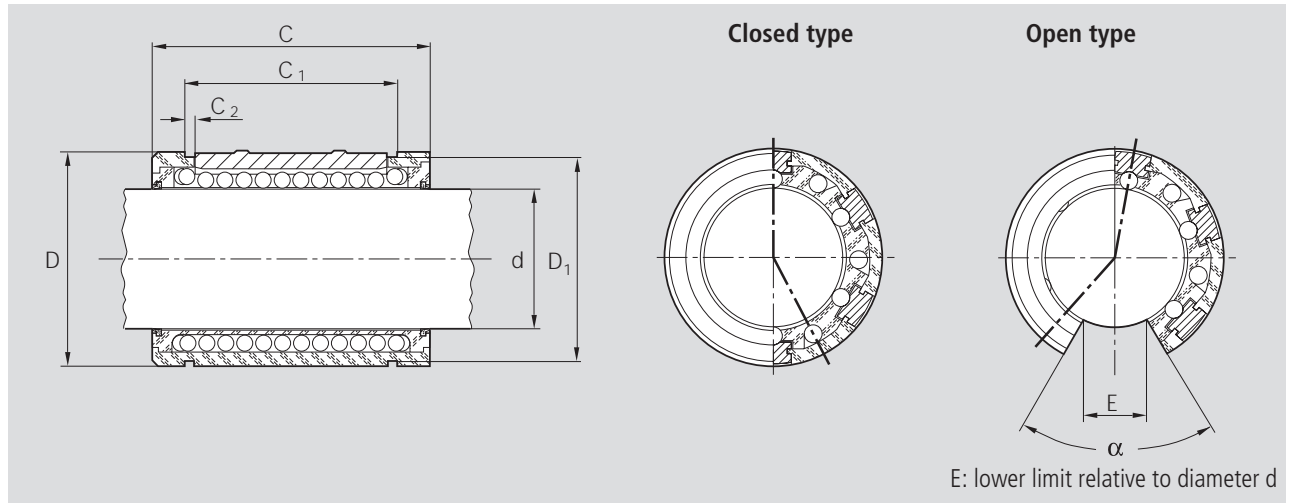

Closed type

$\varnothing d$	$\varnothing D$	Dimensions (mm)				No. of ball circuits	Radial clearance (μm)				Load capacities ¹⁾ (N)	
		C h13	C_1 H13	C_2	D_1		shaft/bore				dyn. C	stat. C_0
						h7/H7	h7/JS7	h6/JS6	h6/K6			
10	19	29	21.6	1.3	18	5	+40 +11	+30 0	+23 +1	+18 -3	550	330
12	22	32	22.6	1.3	21	5	+43 +12	+33 +1	+25 +2	+21 -3	770	420
16	26	36	24.6	1.3	24.9	5	+43 +12	+33 +1	+25 +2	+21 -3	940	530
20	32	45	31.2	1.6	30.5	6	+49 +13	+37 0	+28 +1	+23 -4	1860	1050
25	40	58	43.7	1.85	38.5	6	+49 +13	+37 0	+28 +1	+23 -4	3640	2180
30	47	68	51.7	1.85	44.5	6	+49 +13	+37 0	+28 +1	+23 -4	4420	2790
40	62	80	60.3	2.15	58.5	6	+57 +14	+42 -1	+31 +1	+25 -4	7590	4350
50	75	100	77.3	2.65	71.5	6	+57 +14	+42 -1	+31 +1	+25 -4	11100	6470

Open type

$\varnothing d$	$\varnothing D$	Dimensions (mm)						Angle ($^\circ$) α	No. of ball circuits	Radial clearance (μm)				Load capacities ²⁾ (N)	
		C h13	C_1 H13	C_2	D_1	E	shaft/bore				dyn. C	stat. C_0			
									h7/H7	h7/JS7	h6/JS6	h6/K6			
12	22	32	22.6	1.3	21	6.5	66	4	+43 +12	+33 +1	+25 +2	+21 -3	880	510	
16	26	36	24.6	1.3	24.9	9	68	4	+43 +12	+33 +1	+25 +2	+21 -3	1060	630	
20	32	45	31.2	1.6	30.5	9	55	5	+49 +13	+37 0	+28 +1	+23 -4	1880	1070	
25	40	58	43.7	1.85	38.5	11.5	57	5	+49 +13	+37 0	+28 +1	+23 -4	3680	2250	
30	47	68	51.7	1.85	44.5	14	57	5	+49 +13	+37 0	+28 +1	+23 -4	4470	2880	
40	62	80	60.3	2.15	58.5	19.5	56	5	+57 +14	+42 -1	+31 +1	+25 -4	7680	4480	
50	75	100	77.3	2.65	71.5	22.5	54	5	+57 +14	+42 -1	+31 +1	+25 -4	11200	6620	

¹⁾ The load capacities stated are minimum values as the position and direction of load cannot always be precisely defined.

²⁾ The stated load capacities apply when the load is acting along the line $\rho = 0^\circ$.

STAR – Linear Sets with Super Linear Bushings **A** or **B**

Overview

Closed type

For high-precision guidance with extreme ease of mounting. Version with fixed working bore diameter.

Adjustable type

For use when zero clearance or preload is required. The desired radial clearance is established by means of an adjusting screw. These Linear Sets are adjusted to zero clearance before delivery.

Open type

For long guideways when the shafts must be supported and high rigidity is required.

Open type, adjustable

For use when zero clearance or preload is required. The desired radial clearance is established by means of an adjusting screw. These Linear Sets are adjusted to zero clearance before delivery.

With side opening

Takes up forces from all directions without reduction of load capacity.

With side opening, adjustable

For use when zero clearance or preload is required. The desired radial clearance is established by means of an adjusting screw. These Linear Sets are adjusted to zero clearance before delivery.

Flanged type

This element was developed as a complement to our Linear Set series for use in applications requiring the shaft to be arranged at right angles to the mounting base.

Linear Sets

Tandem Linear Sets

Super Linear Bushings A with self-alignment feature		Super Linear Bushings B without self-alignment feature	Super Linear Bushings A with self-alignment feature	
Aluminum housing	Cast iron housing		Aluminum housing	
1035-...	1065-...		1085-...	
1036-...	1066-...		1032-...	
1037-...	1067-...		1087-...	
1038-...	1068-...		1034-...	
1071-...	1073-...			
1072-...	1074-...			
	1081-...		1083-...	

Advantages/Mounting Instructions

Advantages

High load capacity and rigidity

These Linear Sets afford high rigidity irrespective of the direction of load action and even when their high load-carrying capacities are utilized to the full.

Compact block design and ease of mounting in the aluminum version

The Super Linear Bushing is completely enclosed in the compact housing to protect it against all external impacts. Tapped through-holes make it possible to insert the screws from above or below. A fitting edge along the block facilitates lining up during installation and prevents misalignment of the assembly. Center-bores are provided for the user to drill locating pin holes for extra stability.

High precision and reliability

The housing design and the integral Super Linear Bushing ensure high precision and functional reliability.

Zero-clearance

The adjustable versions can be used to achieve zero clearance assemblies.

Operating temperatures

These Linear Sets are resistant to temperatures up to 100 °C.

Mounting instructions

Radial clearance

The radial clearance values given in the tables have been obtained by statistical methods and are representative of the values to be expected in actual practice. Adjustable types of Linear Sets are adjusted to zero clearance (when screwed down) on a shaft of diameter accurate to a tolerance of h5 (lower limit) before leaving the factory.

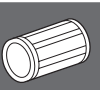

Vertical dimensions

The tables for Linear Sets contain tolerance values for the height dimension 'H'. These tolerance values have been obtained by statistical methods and are representative of the values to be expected in actual practice.

Screws

We recommend screws to ISO 4762-8.8 for mounting Linear Sets.

Lubrication

Whether grease is being applied for the first time or in-service, the shaft must always be inserted in the bushing. Add grease until the lubricant emerges.

Notes on mounting of Linear Sets with side opening

Without fitting edge

- Align first shaft mounted on shaft support rail and screw down support rail.
- Align second shaft to ensure parallelism and screw down support rail.
- Push Linear Sets onto shafts and screw down on the machine table.

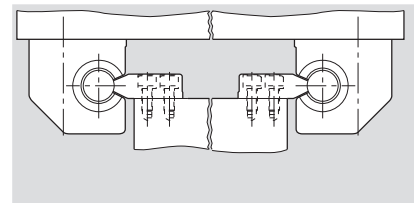

With fitting edge

- Push first shaft mounted on shaft support rail into contact with fitting edge and screw down support rail.
- Align second shaft to ensure parallelism and screw down support rail.
- Push Linear Sets onto the shafts. Further assembly:

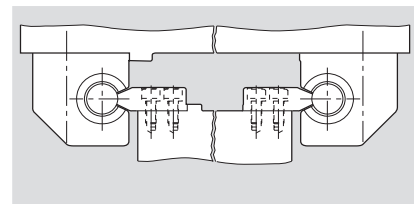

- a) With two fitting edges (one on machine base and one on table): Push the Linear Sets on the first shaft into contact with the fitting edge on the machine table and screw down. Screw down the Linear Sets on the second shaft to the machine table.

- b) With only one fitting edge (on the machine base): Screw Linear Sets down to the machine table.

STAR – Linear Sets with Super Linear Bushings **A** or **B**

Linear Sets, 1035- closed type

Linear Sets, 1036- adjustable

Structural design

- Precision Housing, lightweight series (aluminum)
- Super Linear Bushing with or without self-alignment feature
- External seals
- Fully sealed
- Lubricatable

Ordering data

closed type



Shaft Ø d (mm)	Part numbers		Mass (kg)
	with Super Linear Bushing A lubricatable with two seals	with Super Linear Bushing B lubricatable with two seals	
10	1035-610-20	1035-810-20	0.10
12	1035-612-20	1035-812-20	0.13
16	1035-616-20	1035-816-20	0.20
20	1035-620-20	1035-820-20	0.34
25	1035-625-20	1035-825-20	0.65
30	1035-630-20	1035-830-20	0.97
40	1035-640-20	1035-840-20	1.80
50	1035-650-20	1035-850-20	3.00

adjustable



Shaft Ø d (mm)	Part numbers		Mass (kg)
	with Super Linear Bushing A lubricatable with two seals	with Super Linear Bushing B lubricatable with two seals	
10	1036-610-20	1036-810-20	0.10
12	1036-612-20	1036-812-20	0.13
16	1036-616-20	1036-816-20	0.20
20	1036-620-20	1036-820-20	0.34
25	1036-625-20	1036-825-20	0.65
30	1036-630-20	1036-830-20	0.97
40	1036-640-20	1036-840-20	1.80
50	1036-650-20	1036-850-20	3.00

The figures for dynamic load-carrying capacity have been calculated assuming a nominal travel of 100,000 m. For a nominal travel of 50,000 m, the 'C' figures in the table must be multiplied by a factor of 1.26.

Dimensions

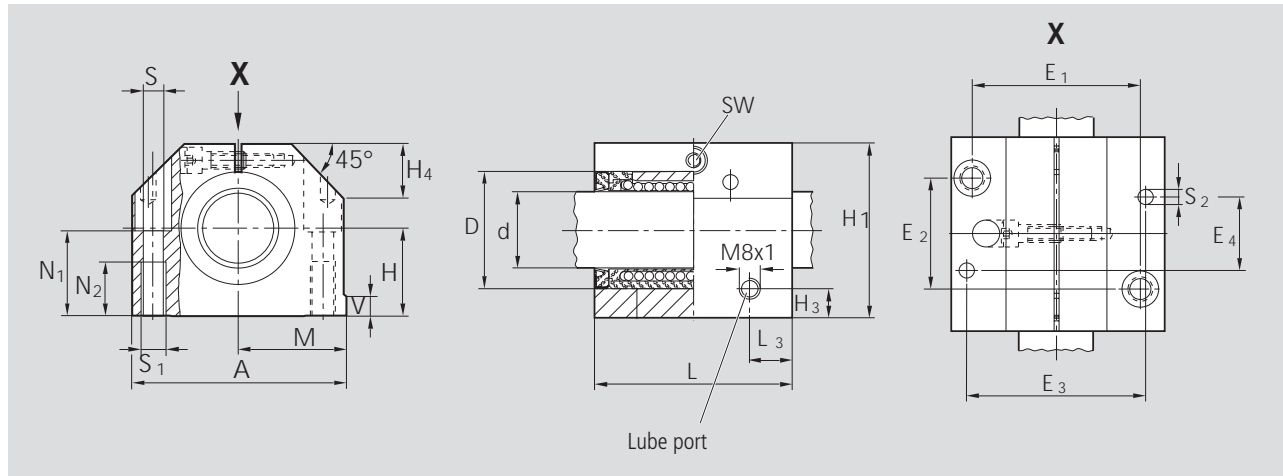

Dimensions (mm)																				
Ø d	D	H ¹⁾ +0.008 -0.016	H ₁	M ¹⁾ ±0.01	A	L	E ₁	E ₂	E ₃	E ₄	S ²⁾	S ₁	S ₂ ³⁾	N ₁	N ₂	H ₃	L ₃	V	SW	H ₄
10	19	16	31.5	20	40	36	29±0.15	20±0.15	31	29	4.3	M5	4	15	11	10	10.5	5	2.5	10
12	22	18	35	21.5	43	39	32±0.15	23±0.15	34	32	4.3	M5	4	16.5	11	10	10.5	5	2.5	10
16	26	22	42	26.5	53	43	40±0.15	26±0.15	42	35	5.3	M6	4	21	13	10	11.5	5	3	13
20	32	25	50	30	60	54	45±0.15	32±0.15	50	45	6.6	M8	5	24	18	10	13.5	5	4	16
25	40	30	60	39	78	67	60±0.15	40±0.15	64	20	8.4	M10	6	29	22	10	15	6.5	5	20
30	47	35	70	43.5	87	79	68±0.15	45±0.15	72	30	8.4	M10	6	34	22	11.5	16	8	5	22
40	62	45	90	54	108	91	86±0.15	58±0.15	90	35	10.5	M12	8	44	26	14	18	10	6	28
50	75	50	105	66	132	113	108±0.20	50±0.20	108	42	13.5	M16	10	49	34	12.5	22	12	8	37



Ø d (mm)	Radial clearance (µm)		Load capacities ⁴⁾ (N)
	1035- shaft h6	1036- h7	
10	+36 +9	+40 +11	dyn. C 550 stat. C ₀ 330
12	+38 +10	+43 +12	adjusted prior to delivery to zero clearance on h5 shaft (lower limit) when screwed down
16	+38 +10	+43 +12	
20	+43 +11	+49 +13	
25	+43 +11	+49 +13	
30	+43 +11	+49 +13	
40	+50 +12	+57 +14	
50	+50 +12	+57 +14	

- 1) When screwed down, relative to shaft nominal dimension d.
- 2) Mounting screws to ISO 4762-8.8
- 3) Center-bores for locating pin holes
- 4) The load capacities stated are minimum values as the position and direction of load cannot always be precisely defined.

STAR – Linear Sets with Super Linear Bushings **A** or **B**

**Linear Sets, 1037-
open type**

**Linear Sets, 1038-
open type, adjustable**

Structural design

- Precision Housing, lightweight series (aluminum)
- Retention by means of grooved taper pin
- Super Linear Bushing with or without self-alignment feature
- External seals
- Lubricatable

Ordering data

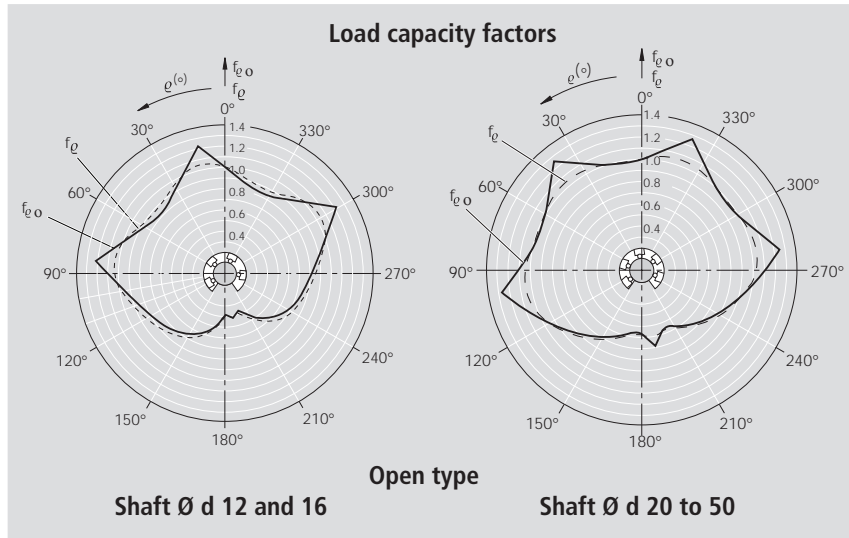

Shaft Ø d (mm)	Part numbers		Mass (kg)
	with Super Linear Bushing A lubricatable with two seals	with Super Linear Bushing B lubricatable with two seals	
12	1037-612-20	1037-812-20	0.11
16	1037-616-20	1037-816-20	0.17
20	1037-620-20	1037-820-20	0.30
25	1037-625-20	1037-825-20	0.57
30	1037-630-20	1037-830-20	0.86
40	1037-640-20	1037-840-20	1.60
50	1037-650-20	1037-850-20	2.60

Shaft Ø d (mm)	Part numbers		Mass (kg)
	with Super Linear Bushing A lubricatable with two seals	with Super Linear Bushing B lubricatable with two seals	
12	1038-612-20	1038-812-20	0.11
16	1038-616-20	1038-816-20	0.17
20	1038-620-20	1038-820-20	0.30
25	1038-625-20	1038-825-20	0.57
30	1038-630-20	1038-830-20	0.86
40	1038-640-20	1038-840-20	1.60
50	1038-650-20	1038-850-20	2.60

The figures for dynamic load-carrying capacity have been calculated assuming a nominal travel of 100,000 m. For a nominal travel of 50,000 m, the 'C' figures in the table must be multiplied by a factor of 1.26.

Dimensions

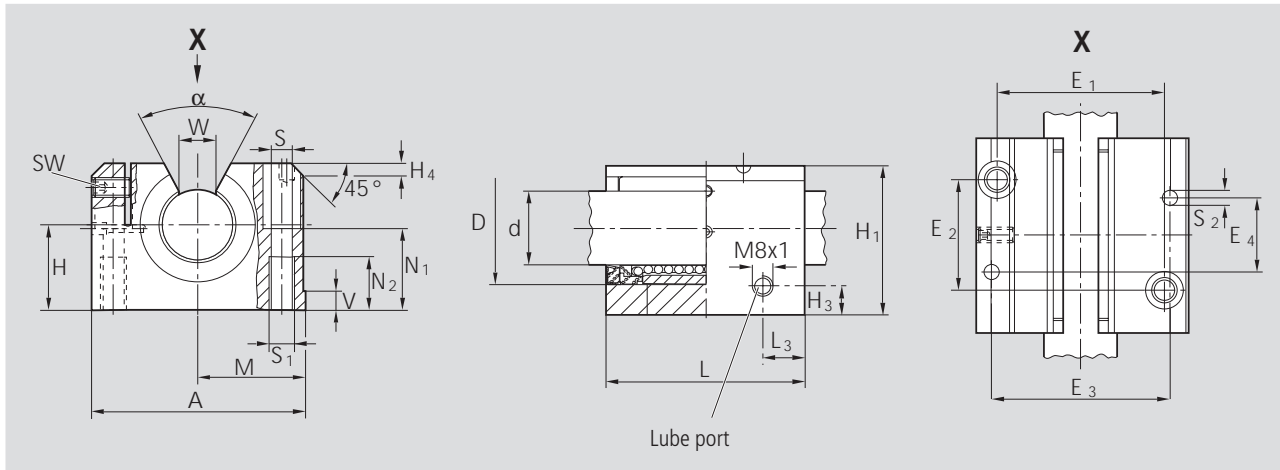

Dimensions (mm)																					
$\varnothing d$	D	H ²⁾	H ₁	M ²⁾	A	L	E ₁	E ₂	E ₃	E ₄	S ³⁾	S ₁	S ₂ ⁴⁾	N ₁	N ₂	H ₃	L ₃	V	SW	W ⁵⁾	H ₄
		+0.008 -0.016		±0.01																	
12	22	18	28	21.5	43	39	32±0.15	23±0.15	34	32	4.3	M5	4	16.5	11	10	10.5	5	2.5	6.5	1.5
16	26	22	35	26.5	53	43	40±0.15	26±0.15	42	35	5.3	M6	4	21	13	10	11.5	5	2.5	9	2.5
20	32	25	42	30	60	54	45±0.15	32±0.15	50	45	6.6	M8	5	24	18	10	13.5	5	2.5	9	3.5
25	40	30	51	39	78	67	60±0.15	40±0.15	64	20	8.4	M10	6	29	22	10	15	6.5	3	11.5	4
30 ¹⁾	47	35	60	43.5	87	79	68±0.15	45±0.15	72	30	8.4	M10	6	34	22	11.5	16	8	3	14	6
40 ¹⁾	62	45	77	54	108	91	86±0.15	58±0.15	90	35	10.5	M12	8	44	26	14	18	10	4	19.5	6
50 ¹⁾	75	50	88	66	132	113	108±0.20	50±0.20	108	42	13.5	M16	10	49	34	12.5	22	12	5	22.5	6

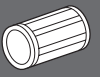

Shaft $\varnothing d$ (mm)	Angle (°) α	Radial clearance ⁶⁾ (μm)		Load capacities ⁷⁾ (N)	dyn. C	stat. C ₀
		1037- shaft h6	1038- shaft h7			
12	66	+28 -1	+33 +1	adjusted prior to delivery to zero clearance on h5 shaft (lower limit) when screwed down	880	510
16	68	+28 -1	+33 +1		1060	630
20	55	+31 -2	+37 0		1880	1070
25	57	+31 -2	+37 0		3680	2250
30 ¹⁾	57	+31 -2	+37 0		4470	2880
40 ¹⁾	56	+35 -3	+42 -1		7680	4480
50 ¹⁾	54	+35 -3	+42 -1		11200	6620

- 1) In these sizes, the locating screw is on the opposite side to that shown in the illustration.
- 2) When screwed down, relative to shaft nominal dimension d .
- 3) Mounting screws to ISO 4762-8.8
- 4) Center-bores for locating pin holes
- 5) Lower limit relative to shaft nominal dimension d .
- 6) When screwed down.
- 7) The load capacities apply when the load is acting along the line $\varrho = 0^\circ$.

STAR – Linear Sets with Super Linear Bushings **A** or **B**

**Linear Sets, 1071-
with side opening**

**Linear Sets, 1072-
with side opening, adjustable**

Structural design

- Precision Housing, lightweight series (aluminum)
- Retention by means of grooved taper pin
- Super Linear Bushing with or without self-alignment feature
- External seals
- Lubricatable

The load carrying capacity of open linear bushings is considerably reduced when the load is applied to the "open" portion of the bushing. The Linear Set with Side Opening, lightweight series, has been developed to overcome this disadvantage and to permit selective circumferential positioning of the open linear bushing.

Ordering data

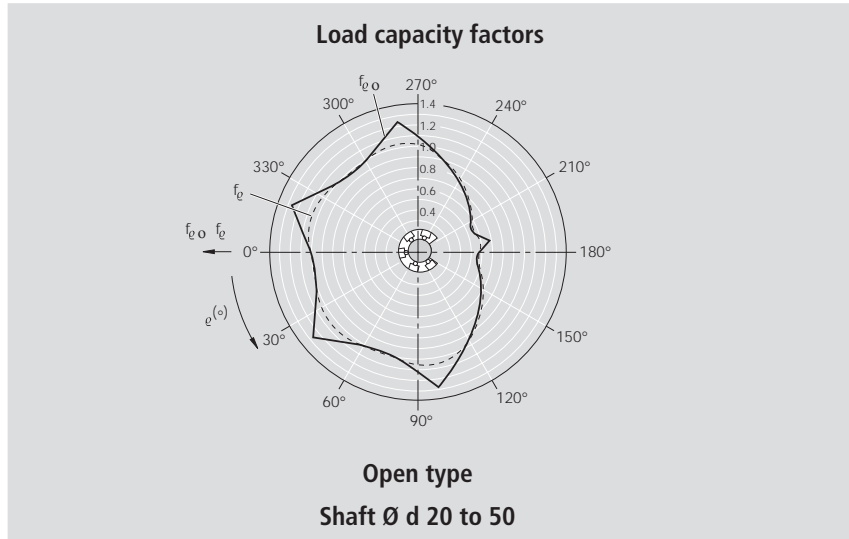

Note:

The diagram corresponds to the mounting position as shown on the photos below and therefore differs from the information given in "Technical Data".

Shaft Ø d (mm)	Part numbers		Mass (kg)
	with Super Linear Bushing A lubricatable with two seals	with Super Linear Bushing B lubricatable with two seals	
20	1071-620-20	1071-820-20	0.42
25	1071-625-20	1071-825-20	0.8
30	1071-630-20	1071-830-20	1.2
40	1071-640-20	1071-840-20	2.0
50	1071-650-20	1071-850-20	3.2

Shaft Ø d (mm)	Part numbers		Mass (kg)
	with Super Linear Bushing A lubricatable with two seals	with Super Linear Bushing B lubricatable with two seals	
20	1072-620-20	1072-820-20	0.42
25	1072-625-20	1072-825-20	0.8
30	1072-630-20	1072-830-20	1.2
40	1072-640-20	1072-840-20	2.0
50	1072-650-20	1072-850-20	3.2

The figures for dynamic load-carrying capacity have been calculated assuming a nominal travel of 100,000 m. For a nominal travel of 50,000 m, the 'C' figures in the table must be multiplied by a factor of 1.26.



Dimensions

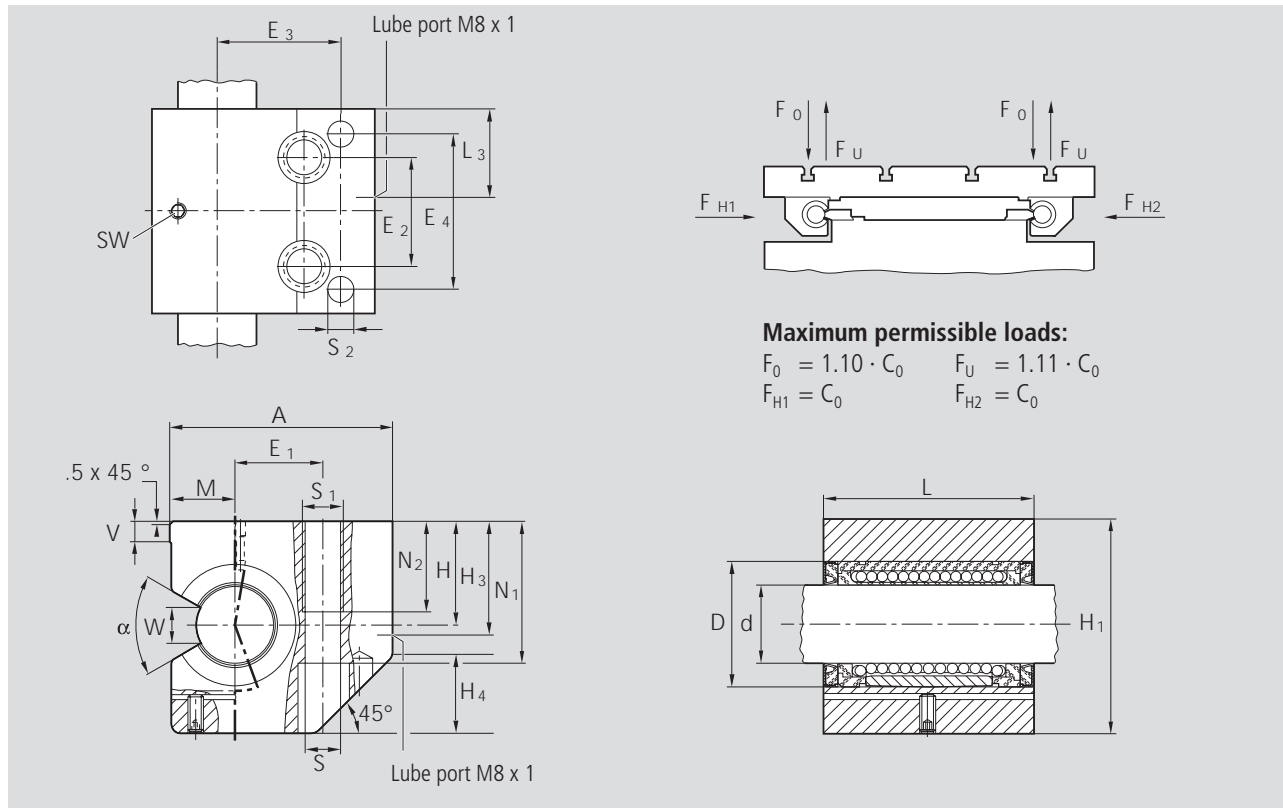

Maximum permissible loads:

$$F_0 = 1.10 \cdot C_0 \quad F_U = 1.11 \cdot C_0$$

$$F_{H1} = C_0 \quad F_{H2} = C_0$$

Dimensions (mm)																					
Ø d	D	H ²⁾	H ₁	M ²⁾	A	L	E ₁	E ₂	E ₃	E ₄	S ³⁾	S ₁	S ₂ ⁴⁾	N ₁	N ₂	V	SW	W ⁵⁾	H ₃	L ₃	H ₄
		+0.008 -0.016		±0.01				±0.15	±0.15												
20 ¹⁾	32	30	60	17	60	54	22	30	33	42	8.4	M10	6	42	15	5	2.5	9	32	23.5	22
25 ¹⁾	40	35	72	21	75	67	28	36	42	52	10.5	M12	8	50	18	6.5	3	11.5	38	29	26
30	47	40	82	25	86	79	34	42	48	60	13.5	M16	10	55	24	8	3	14	44	34	30
40	62	45	100	32	110	91	43	48	62	68	15.5	M20	12	67	30	10	4	19.5	50	40	38
50	75	50	115	38	127	113	50	62	70	85	17.5	M20	12	78	30	12	5	22.5	56	48	45

Ø d (mm)	Angle (°) α	Radial clearance ⁶⁾ (µm)		Load capacities ⁷⁾ (N)		
		1071- shaft h6	1072- h7	dyn. C	stat. C ₀	
20 ¹⁾	55	+31 -2	+37 0	adjusted prior to delivery to zero clearance on h5 shaft (lower limit) when screwed down	1880	1070
25 ¹⁾	57	+31 -2	+37 0		3680	2250
30	57	+31 -2	+37 0		4470	2880
40	56	+35 -3	+42 -1		7680	4480
50	54	+35 -3	+42 -1		11200	6620

1) In these sizes, the locating screw is on the opposite side to that shown in the illustration.

2) When screwed down, relative to shaft nominal dimension d.

3) Mounting screws to ISO 4762-8.8.

4) Center-bores for locating pin holes.

5) Lower limit relative to shaft nominal dimension d.

6) When screwed down.

7) The load capacities apply when the load is acting in the direction shown by the arrows at F_{H1} or F_{H2}.

Please refer also to the mounting instructions for Linear Sets with side opening.

STAR – Linear Sets with Super Linear Bushings

Tandem version

Linear Sets, 1085-
closed type

Linear Sets, 1032-
adjustable

Structural design

- Precision Tandem Linear Set, light-weight series (aluminum)
- Two Super Linear Bushings 
- External seals
- Fully sealed
- Fitting edge
(for adjustable Tandem version)
- Lubricatable

Ordering data

closed type



Shaft Ø d (mm)	Part numbers	Mass (kg)
12	1085-612-20	0.27
16	1085-616-20	0.41
20	1085-620-20	0.72
25	1085-625-20	1.35
30	1085-630-20	2.01
40	1085-640-20	3.67
50	1085-650-20	6.30

adjustable



Shaft Ø d (mm)	Part numbers	Mass (kg)
10	1032-610-20	0.20
12	1032-612-20	0.27
16	1032-616-20	0.41
20	1032-620-20	0.72
25	1032-625-20	1.35
30	1032-630-20	2.01
40	1032-640-20	3.67
50	1032-650-20	6.30

The figures for dynamic load-carrying capacity have been calculated assuming a nominal travel of 100,000 m. For a nominal travel of 50,000 m, the 'C' figures in the table must be multiplied by a factor of 1.26.

Dimensions

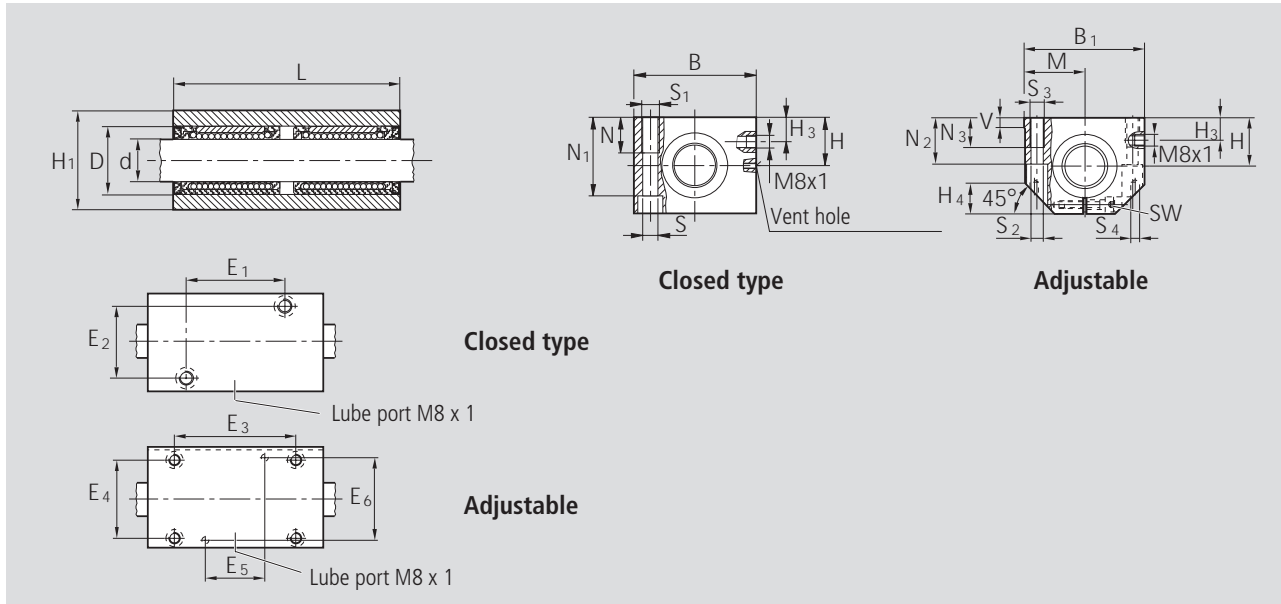

Dimensions (mm)																										
Ø d	D	H ¹⁾	H ₁	H ₃	M ¹⁾	B	B ₁	L	E ₁	E ₂	E ₃	E ₄	E ₅	E ₆	S ²⁾	S ₁	S ₂ ²⁾	S ₃	S ₄ ³⁾	N	N ₁	N ₂	N ₃	V	SW	H ₄
10	19	16	31.5	9	20	-	40	70	-	-	52	29	20	31	-	-	4.3	M5	4	-	-	15	11	5	2.5	10
12	22	18	35	10	21.5	42	43	76	40	30	56	32	24	34	5.3	M6	4.3	M5	4	13	28	16.5	11	5	2.5	10
16	26	22	42	12	26.5	50	53	84	45	36	64	40	28	42	5.3	M6	5.3	M6	4	13	35	21	13	5	3	13
20	32	25	50	13	30	60	60	104	55	45	76	45	32	50	6.4	M8	6.6	M8	5	18	41	24	18	5	4	16
25	40	30	60	15	39	74	78	130	70	54	94	60	42	64	8.4	M10	8.4	M10	6	22	49	29	22	6.5	5	20
30	47	35	70	16	43.5	84	87	152	85	62	106	68	52	72	10.5	M12	8.4	M10	6	26	56	34	22	8	5	22
40	62	45	90	20	54	108	108	176	100	80	124	86	60	90	13.5	M16	10.5	M12	8	34	74	44	26	10	6	28
50	75	50	105	20	66	130	132	224	125	100	160	108	80	108	13.5	M16	13.5	M16	10	34	89	49	35	12	8	37

Ø d (mm)	Radial clearance (µm)		Load capacities ⁴⁾ (N)
	1085- shaft h6	1032- h7	
10	-	-	dyn. C
12	+38 +10	+43 +12	stat. C ₀
16	+38 +10	+43 +12	890
20	+43 +11	+49 +13	1250
25	+43 +11	+49 +13	1530
30	+43 +11	+49 +13	3020
40	+50 +12	+57 +14	5910
50	+50 +12	+57 +14	7180
			12300
			18000

Note on lubrication for Linear Sets 1085:
Lubricate only when shaft inserted; add lubricant until excess emerges at the vent hole.

- 1) When screwed down, relative to shaft nominal dimension d.
- 2) Mounting screws to ISO 4762-8.8.
- 3) Center-bores for locating pin holes.
- 4) Load capacity when both Linear Bushings are equally loaded. The load capacities stated are minimum values as the position and direction of load cannot always be precisely defined.

STAR – Linear Sets with Super Linear Bushings

Tandem version

Linear Sets, 1087-
open type

Linear Sets, 1034-
open type, adjustable

Structural design

- Precision Tandem Linear Set, lightweight series (aluminum)
- Two Super Linear Bushings 
- Two external seals
- Fitting edge (for adjustable Tandem version)
- Lubricatable

Ordering data



Shaft Ø d (mm)	Part numbers	Mass (kg)
12	1087-612-20	0.22
16	1087-616-20	0.34
20	1087-620-20	0.62
25	1087-625-20	1.17
30	1087-630-20	1.68
40	1087-640-20	3.15
50	1087-650-20	5.50



Shaft Ø d (mm)	Part numbers	Mass (kg)
12	1034-612-20	0.22
16	1034-616-20	0.34
20	1034-620-20	0.62
25	1034-625-20	1.17
30	1034-630-20	1.68
40	1034-640-20	3.15
50	1034-650-20	5.50

The figures for dynamic load-carrying capacity have been calculated assuming a nominal travel of 100,000 m. For a nominal travel of 50,000 m, the 'C' figures in the table must be multiplied by a factor of 1.26.

Dimensions

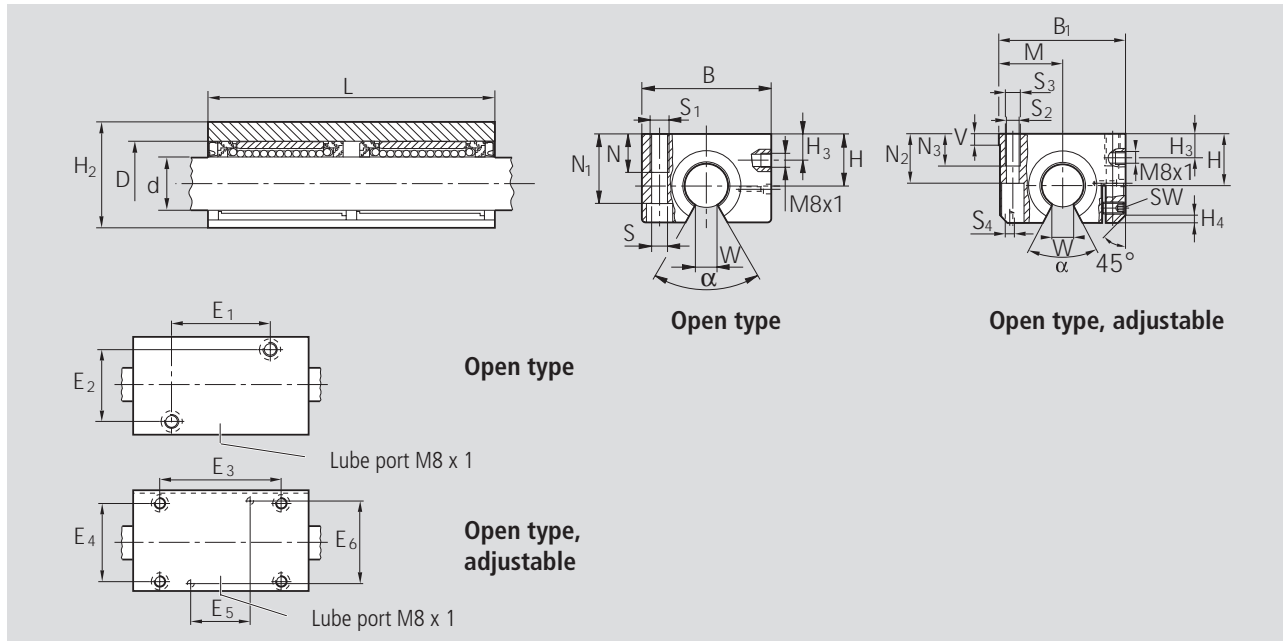

		Dimensions (mm)																									
Ø d	D +0.008 -0.016	H ²⁾ H ₂	H ₃	M ²⁾ ±0.01	B	B ₁	L	E ₁	E ₂	E ₃	E ₄	E ₅	E ₆	S ³⁾	S ₁	S ₂ ⁴⁾	S ₃	S ₄ ⁵⁾	N	N ₁	N ₂	N ₃	V	SW	W ⁶⁾	H ₄	
12	22	18	30 ¹⁾	10	21.5	42	43	76	40	30	56	32	24	34	5.3	M6	4.3	M5	4	13	25	16.5	11	5	2.5	6.5	1.5
16	26	22	35	12	26.5	50	53	84	45	36	64	40	28	42	5.3	M6	5.3	M6	4	13	29.5	21	13	5	2.5	9	2.5
20	32	25	42	13	30	60	60	104	55	45	76	45	32	50	6.4	M8	6.6	M8	5	18	35.5	24	18	5	2.5	9	3.5
25	40	30	51	15	39	74	78	130	70	54	94	60	42	64	8.4	M10	8.4	M10	6	22	43	29	22	6.5	3	11.5	4
30	47	35	60	16	43.5	84	87	152	85	62	106	68	52	72	10.5	M12	8.4	M10	6	26	50.5	34	22	8	3	14	6
40	62	45	77	20	54	108	108	176	100	80	124	86	60	90	13.5	M16	10.5	M12	8	34	66	44	26	10	4	19.5	6
50	75	50	88	10	66	130	132	224	125	100	160	108	80	108	13.5	M16	13.5	M16	10	34	77	49	35	12	5	22.5	6

Ø d (mm)	Angle (°) α	Radial clearance ⁷⁾ (µm)		Load capacities ⁸⁾ (N)
		1087- shaft h ₆	1034- shaft h ₇	
12	66	+28 -1	+33 +1	dyn. C: 1430 stat. C ₀ : 1020
16	68	+28 -1	+33 +1	1720 / 1260
20	55	+31 -2	+37 0	3050 / 2140
25	57	+31 -2	+37 0	5980 / 4500
30	57	+31 -2	+37 0	7260 / 5760
40	56	+35 -3	+42 -1	12500 / 8960
50	54	+35 -3	+42 -1	18200 / 13240

adjusted prior to delivery to zero clearance on h5 shaft (lower limit) when screwed down

- 1) In the open, adjustable version, H₂ = 28 mm.
- 2) When screwed down, relative to shaft nominal dimension d.
- 3) Mounting screws to DIN 6912-8.8.
- 4) Mounting screws to ISO 4762-8.8.
- 5) Center-bores for locating pin holes.
- 6) Lower limit relative to shaft nominal dimension d.
- 7) When screwed down.
- 8) Load capacity when both Linear Bushings are equally loaded. The load capacities apply when the load is acting along the line $\varrho = 0^\circ$.

STAR – Linear Sets with Super Linear Bushings

Tandem Flanged version

Linear Sets, 1083-

Structural design

- Precision Flanged Housing, lightweight series (aluminum)
- Two Super Linear Bushings 
- Two external seals
- Centering collar
- Fully sealed
- Tapped through holes for screw-mounting from the base
- Lubricatable
- Radial clearance not adjustable

Ordering data



Shaft Ø d (mm)	Part numbers	Mass (kg)
12	1083-612-20	0.20
16	1083-616-20	0.32
20	1083-620-20	0.55
25	1083-625-20	1.00
30	1083-630-20	1.50

The figures for dynamic load-carrying capacity have been calculated assuming a nominal travel of 100,000 m. For a nominal travel of 50,000 m, the 'C' figures in the table must be multiplied by a factor of 1.26.

Dimensions

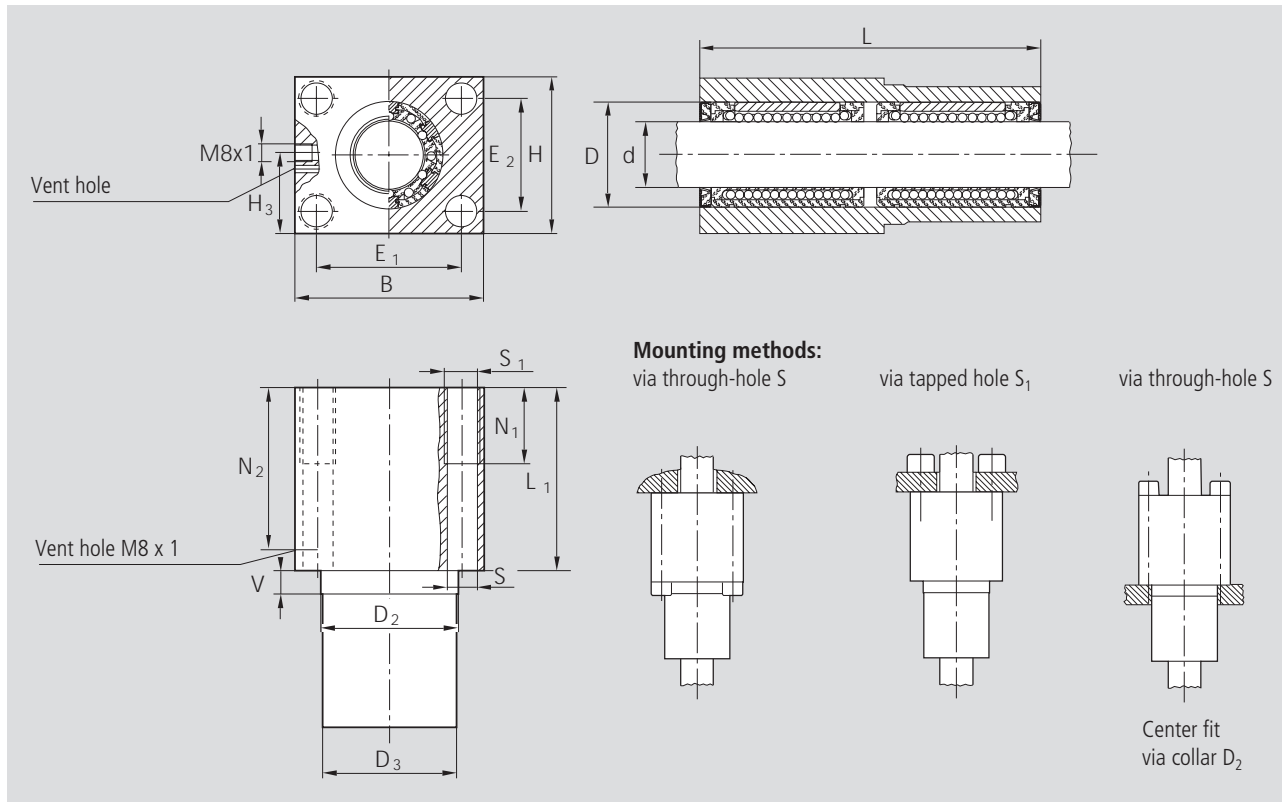

Mounting methods:

via through-hole S

via tapped hole S₁

via through-hole S

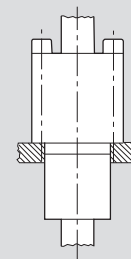
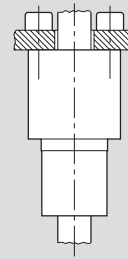
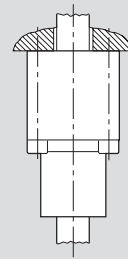

Center fit
via collar D₂

Dimensions (mm)

Ø d	D	D ₂ ¹⁾ g7	D ₃ -0.1 -0.3	H	H ₃	B	L	L ₁	E ₁ ±0.15	E ₂ ±0.15	S ²⁾	S ₁	N ₁	N ₂	V
12	22	30	30	34	19	42	76	46	32	24	5.3	M6	13	36	10
16	26	35	35	40	22	50	84	50	38	28	6.6	M8	18	40	10
20	32	42	42	50	27	60	104	60	45	35	8.4	M10	22	50	10
25	40	52	52	60	32	74	130	73	56	42	10.5	M12	26	63	10
30	47	61	61	70	37	84	152	82	64	50	13.5	M16	34	74	10

Ø d (mm)	Radial clearance (µm)		Load capacities ³⁾ (N)	
	h6 shaft	h7	dyn. C	stat. C ₀
12	+38 +10	+43 +12	1250	840
16	+38 +10	+43 +12	1530	1060
20	+43 +11	+49 +13	3020	2100
25	+43 +11	+49 +13	5910	4360
30	+43 +11	+49 +13	7180	5580

Note on lubrication:

Lubricate only when shaft inserted; add lubricant until excess emerges at the vent hole.

¹⁾ Recommended mounting bore fit: D₂^{H7}

²⁾ Mounting screws to ISO 4762-8.8.

³⁾ Load capacity when both Linear Bushings are equally loaded. The load capacities stated are minimum values as the position and direction of load cannot always be precisely defined.

STAR – Linear Sets with Super Linear Bushings **A** or **B**

Linear Sets, 1065-
closed type

Linear Sets, 1066-
adjustable

Structural design

- Precision Housing (lamellar graphite cast iron)
- Super Linear Bushing with or without self-alignment feature
- Internal seals

Ordering data

closed type



Shaft Ø d (mm)	Part numbers		Mass (kg)
	with Super Linear Bushing A with internal seals	with Super Linear Bushing B with internal seals	
12	1065-612-40	1065-812-40	0.15
16	1065-616-40	1065-816-40	0.24
20	1065-620-40	1065-820-40	0.42
25	1065-625-40	1065-825-40	0.83
30	1065-630-40	1065-830-40	1.22
40	1065-640-40	1065-840-40	2.29
50	1065-650-40	1065-850-40	3.23

adjustable



Shaft Ø d (mm)	Part numbers		Mass (kg)
	with Super Linear Bushing A with internal seals	with Super Linear Bushing B with internal seals	
12	1066-612-40	1066-812-40	0.15
16	1066-616-40	1066-816-40	0.24
20	1066-620-40	1066-820-40	0.41
25	1066-625-40	1066-825-40	0.79
30	1066-630-40	1066-830-40	1.19
40	1066-640-40	1066-840-40	2.26
50	1066-650-40	1066-850-40	3.15

The figures for dynamic load-carrying capacity have been calculated assuming a nominal travel of 100,000 m. For a nominal travel of 50,000 m, the 'C' figures in the table must be multiplied by a factor of 1.26.

Dimensions

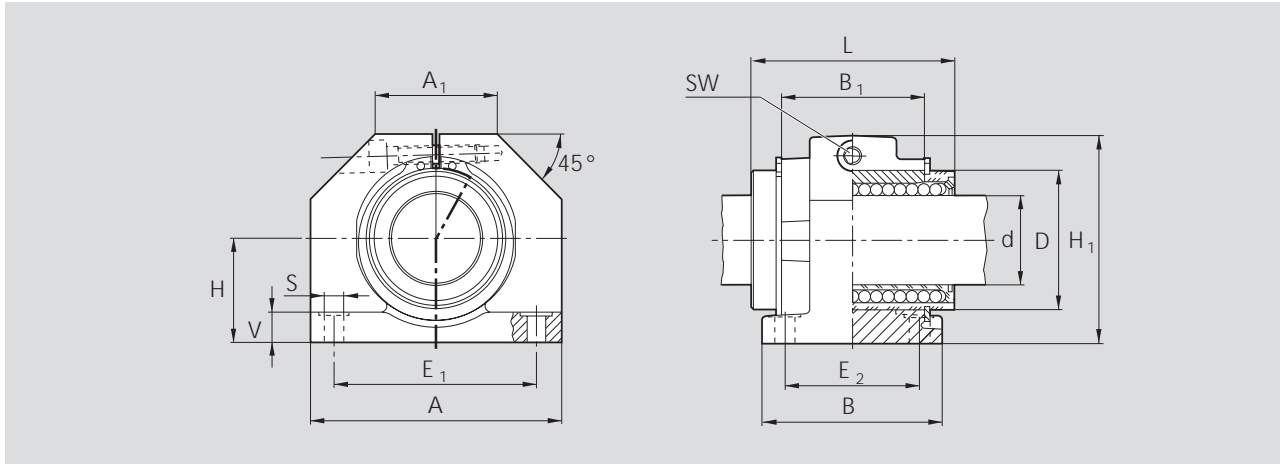

Dimensions (mm)													
Ø d	D	H	H ₁ ¹⁾	L	A ¹⁾	A ₁ ¹⁾	B ¹⁾	B ₁	E ₁	E ₂	S	V ¹⁾	SW
12	22	18	35	32	42	21	32	20	32±0.15	23±0.15	4.5	5.5	2.5
16	26	22	42	36	50	26	35	22	40±0.15	26±0.15	4.5	6.5	3
20	32	25	50	45	60	28	42	28	45±0.15	32±0.15	4.5	8	3
25	40	30	60	58	74	38	54	40	60±0.15	40±0.15	5.5	9	5
30	47	35	70	68	84	41	60	48	68±0.20	45±0.20	6.6	10	5
40	62	45	90	80	108	51	78	56	86±0.20	58±0.20	9	12	6
50	75	50	105	100	130	57	70	72	108±0.20	50±0.20	9	14	8

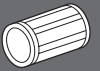

Ø d (mm)	Radial clearance (µm)		Tolerance for H ²⁾ (µm)	Load capacities ³⁾ (N)	
	1065- shaft h6	1066- h7		dyn. C	stat. C ₀
12	+38 +10	+43 +12	+8 -16	770	420
16	+38 +10	+43 +12	+8 -16	940	530
20	+43 +11	+49 +13	+8 -16	1860	1050
25	+43 +11	+49 +13	+8 -16	3640	2180
30	+43 +11	+49 +13	+8 -16	4420	2790
40	+50 +12	+57 +14	+8 -16	7590	4350
50	+50 +12	+57 +14	+13 -21	11100	6470

adjusted prior to delivery to zero clearance on h5 shaft (lower limit) when screwed down

1) Tolerance to DIN 1686-GTB 15.

2) When screwed down, relative to shaft nominal dimension d.

3) The load capacities stated are minimum values as the position and direction of load cannot always be precisely defined.

STAR – Linear Sets with Super Linear Bushings **A** or **B**

**Linear Sets, 1067-
open type**

**Linear Sets, 1068-
open type, adjustable**

Structural design

- Precision Housing (spheroidal graphite cast iron)
- Retention by means of locating screw
- Super Linear Bushings with or without self-alignment feature
- Internal seals

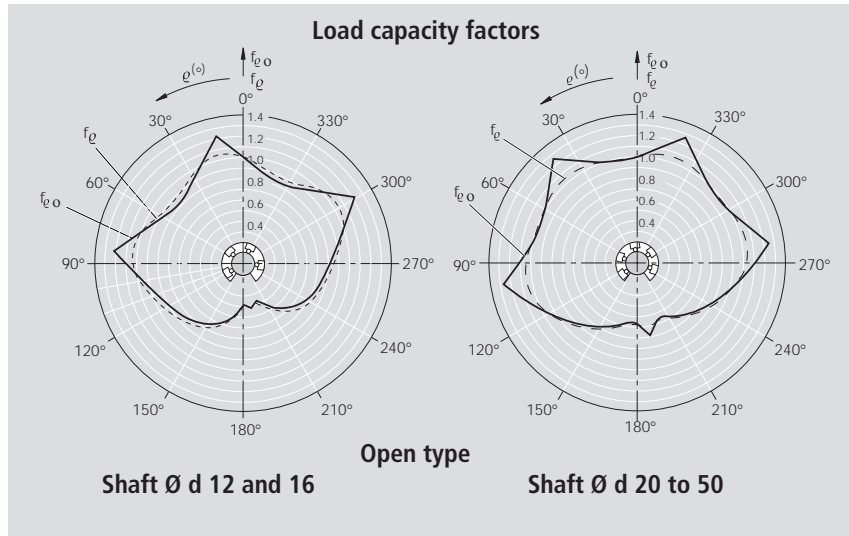

Ordering data



Shaft Ø d (mm)	Part numbers		Mass (kg)
	with Super Linear Bushing A with internal seals	with Super Linear Bushing B with internal seals	
12	1067-612-40	1067-812-40	0.13
16	1067-616-40	1067-816-40	0.20
20	1067-620-40	1067-820-40	0.36
25	1067-625-40	1067-825-40	0.70
30	1067-630-40	1067-830-40	1.05
40	1067-640-40	1067-840-40	2.05
50	1067-650-40	1067-850-40	2.77



Shaft Ø d (mm)	Part numbers		Mass (kg)
	with Super Linear Bushing A with internal seals	with Super Linear Bushing B with internal seals	
12	1068-612-40	1068-812-40	0.12
16	1068-616-40	1068-816-40	0.20
20	1068-620-40	1068-820-40	0.36
25	1068-625-40	1068-825-40	0.69
30	1068-630-40	1068-830-40	1.02
40	1068-640-40	1068-840-40	2.02
50	1068-650-40	1068-850-40	2.71

The figures for dynamic load-carrying capacity have been calculated assuming a nominal travel of 100,000 m. For a nominal travel of 50,000 m, the 'C' figures in the table must be multiplied by a factor of 1.26.



Dimensions

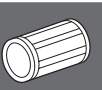
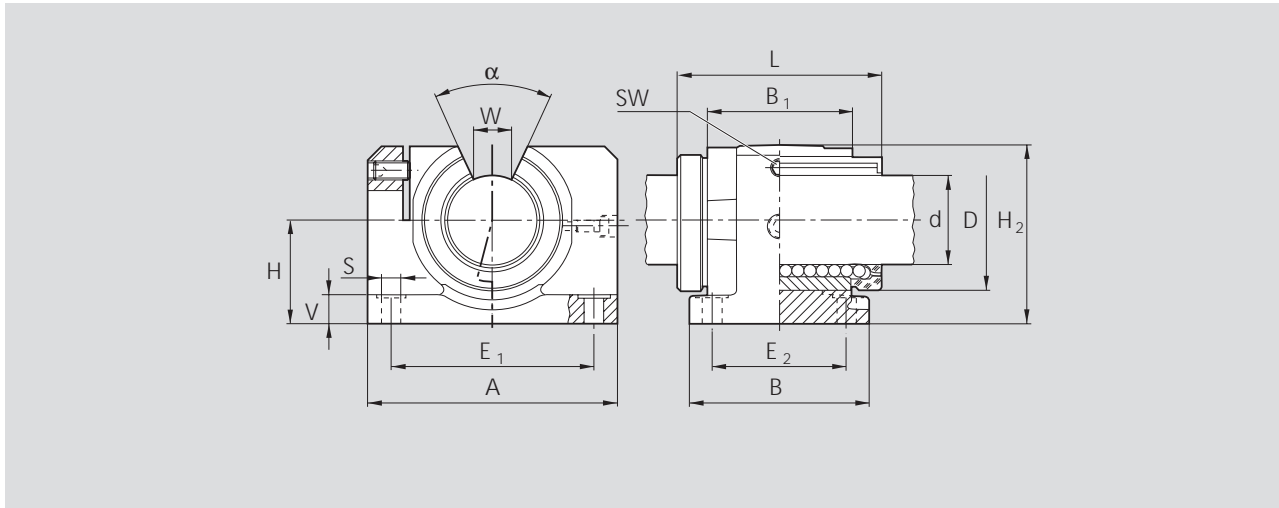

Dimensions (mm)													
Ø d	D	H	H ₂ ²⁾	L	A ²⁾	B ²⁾	B ₁	E ₁	E ₂	S	V ²⁾	W ³⁾	SW
12 ¹⁾	22	18	28	32	42	32	20	32±0.15	23±0.15	4.5	5.5	6.5	2.5
16 ¹⁾	26	22	35	36	50	35	22	40±0.15	26±0.15	4.5	6.5	9	2.5
20 ¹⁾	32	25	42	45	60	42	28	45±0.15	32±0.15	4.5	8	9	2.5
25 ¹⁾	40	30	51	58	74	54	40	60±0.15	40±0.15	5.5	9	11.5	3
30	47	35	60	68	84	60	48	68±0.20	45±0.20	6.6	10	14	3
40	62	45	77	80	108	78	56	86±0.20	58±0.20	9	12	19.5	4
50	75	50	88	100	130	70	72	108±0.20	50±0.20	9	14	22.5	5

Ø d	Angle (°) α	Radial clearance (µm)		Tolerance (µm) for dimension H ⁴⁾ 1067 1068	Load capacities ⁵⁾ (N)	
		1067- shaft h ₆	1068- h ₇		dyn. C	stat. C ₀
12	66	+28 -1	+33 +1	+8 -16	880	510
16	68	+28 -1	+33 +1	+8 -16	1060	630
20	55	+31 -2	+37 0	+8 -16	1880	1070
25	57	+31 -2	+37 0	+8 -16	3680	2250
30	57	+31 -2	+37 0	+8 -16	4470	2880
40	56	+35 -3	+42 -1	+8 -16	7680	4480
50	54	+35 -3	+42 -1	+13 -21	11200	6620

adjusted prior to delivery to zero clearance on h5 shaft (lower limit) when screwed down

- 1) In these sizes, the locating screw is on the opposite side to that shown in the illustration.
- 2) Tolerance to DIN 1686-GTB 15.
- 3) Lower limit relative to shaft nominal dimension d.
- 4) When screwed down, relative to shaft nominal dimension d.
- 5) The load capacities apply when the load is acting along the line $\varrho = 0^\circ$.

STAR – Linear Sets with Super Linear Bushings **A** or **B**

Linear Sets, 1073-
with side opening

Linear Sets, 1074-
with side opening, adjustable

Structural design

- Precision Housing (spheroidal graphite cast iron)
- Retention by means of grooved taper pin
- Super Linear Bushing with or without self-alignment feature
- External seals

The load carrying capacity of open linear bushings is considerably reduced when the load is applied to the "open" portion of the bushing. The Linear Set with Side Opening has been developed to overcome this disadvantage and to permit selective circumferential positioning of the open linear bushing.

Ordering data

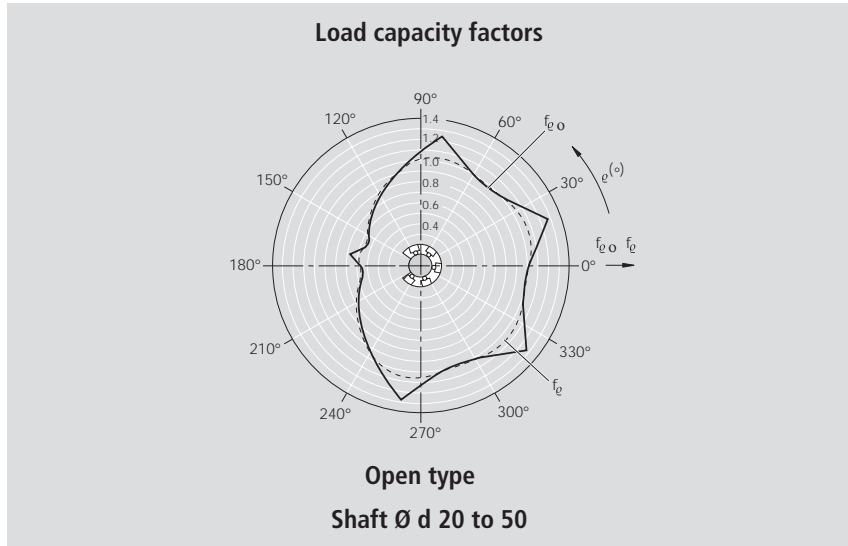

Note:

The diagram corresponds to the mounting position as shown on the photos below and therefore differs from the information given in "Technical Data".

Shaft Ø d (mm)	Part numbers		Mass (kg)
	with Super Linear Bushing A with two seals	with Super Linear Bushing B with two seals	
20	1073-620-00	1073-820-00	1.0
25	1073-625-00	1073-825-00	1.9
30	1073-630-00	1073-830-00	2.8
40	1073-640-00	1073-840-00	4.8
50	1073-650-00	1073-850-00	8.0

Shaft Ø d (mm)	Part numbers		Mass (kg)
	with Super Linear Bushing A with two seals	with Super Linear Bushing B with two seals	
20	1074-620-00	1074-820-00	1.0
25	1074-625-00	1074-825-00	1.9
30	1074-630-00	1074-830-00	2.8
40	1074-640-00	1074-840-00	4.8
50	1074-650-00	1074-850-00	8.0

The figures for dynamic load-carrying capacity have been calculated assuming a nominal travel of 100,000 m. For a nominal travel of 50,000 m, the 'C' figures in the table must be multiplied by a factor of 1.26.



Dimensions

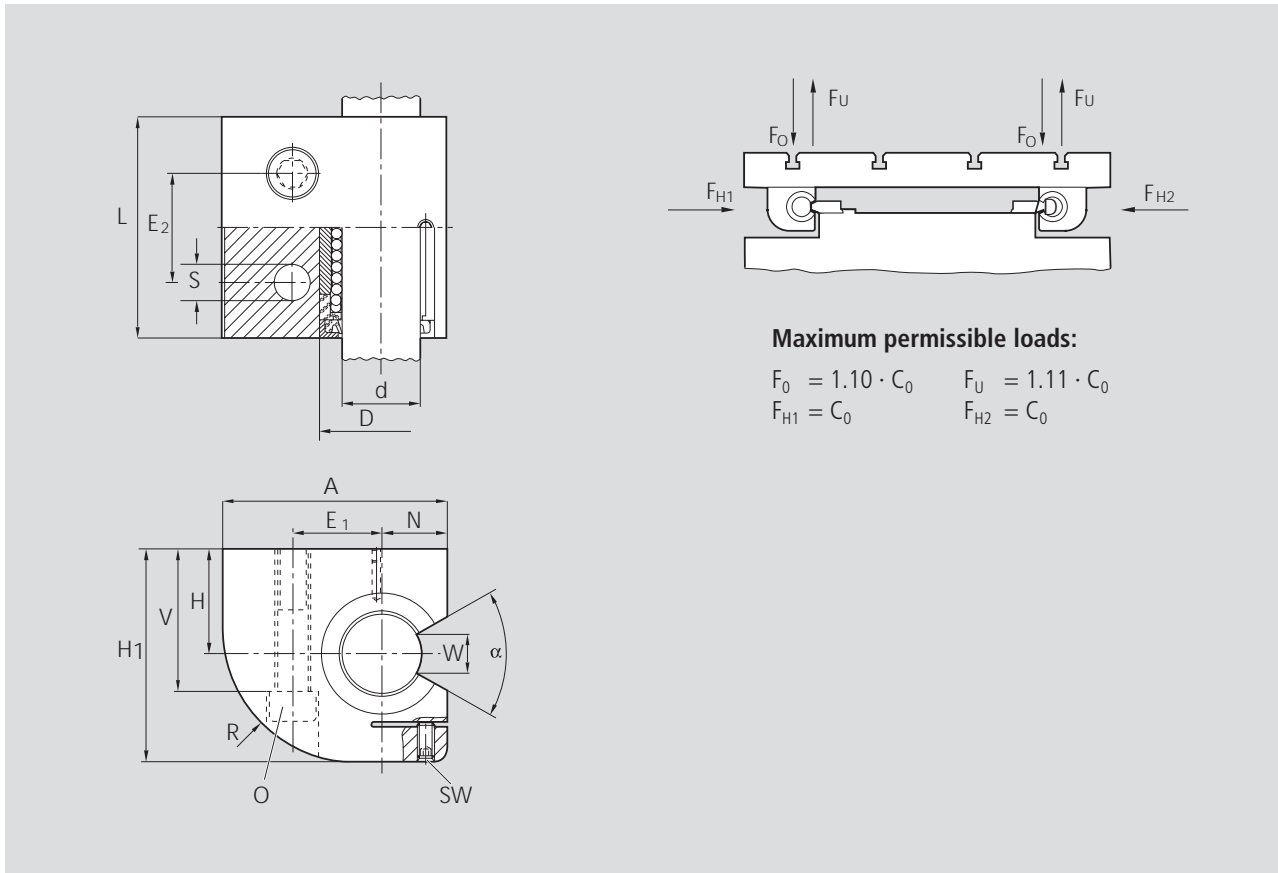

Dimensions (mm)														
Ø d	H	H ₁ ⁽²⁾	L ⁽²⁾	A ⁽²⁾	E ₁	E ₂	N	D	V	S	SW	O ⁽³⁾	R ⁽²⁾	W ⁽⁴⁾
20 ⁽¹⁾	30	60	60	60	22±0.25	30±0.25	17	32	42	9	2.5	M8x60	37	9
25 ⁽¹⁾	35	72	73	75	28±0.25	36±0.25	21	40	50	11	3	M10x70	45	11.5
30	40	82	85	86	34±0.5	42±0.5	25	47	55	13.5	3	M12x80	51	14
40	45	100	97	110	43±0.5	48±0.5	32	62	67	15.5	4	M14x90	66	19.5
50	50	115	125	127	50±0.5	62±0.5	38	75	78	17.5	5	M16x110	77	22.5

Ø d (mm)	Angle (°) α	Tolerance for H ⁽⁵⁾ (µm)	Radial clearance (µm) ⁽⁶⁾		Load capacities ⁽⁷⁾ (N)	Load capacities ⁽⁷⁾ (N)	
			1073- shaft h6	1074- h7		dyn. C	stat. C ₀
20 ⁽¹⁾	55	+8 -16	+31 -2	+37 0	adjusted prior to delivery to zero clearance on h5 shaft (lower limit) when screwed down	1880	1070
25 ⁽¹⁾	57	+8 -16	+31 -2	+37 0		3680	2250
30	57	+8 -16	+31 -2	+37 0		4470	2880
40	56	+8 -16	+35 -3	+42 -1		7680	4480
50	54	+13 -21	+35 -3	+42 -1		11200	6620

1) In these sizes, the locating screw is on the opposite side to that shown in the illustration.

2) Tolerance to DIN 1685-GTB 15.

3) Hex. socket head cap screws to ISO 4762-8.8.

4) Lower limit relative to shaft nominal dimension d.

5) Relative to shaft nominal dimension d.

6) When screwed down.

7) The load capacities apply when the load is acting along the line shown by the arrows at F_{H1} or F_{H2}.

STAR – Linear Sets with Super Linear Bushings **A** or **B**

Linear Sets, 1081- Flanged type

Structural design

- Precision Flanged Housing (lamellar graphite cast iron)
- Two retaining rings, plus two spacer rings (steel) for sizes 12 to 40
- Super Linear Bushings with or without self-alignment feature
- Internal seals
- The radial clearance is not adjustable

Ordering data



Shaft Ø d (mm)	Part numbers		Mass (kg)
	with Super Linear Bushing A with two seals	with Super Linear Bushing B with two seals	
12	1081-612-40	1081-812-40	0.095
16	1081-616-40	1081-816-40	0.16
20	1081-620-40	1081-820-40	0.30
25	1081-625-40	1081-825-40	0.57
30	1081-630-40	1081-830-40	0.85
40	1081-640-40	1081-840-40	1.65
50	1081-650-40	1081-850-40	3.40

The figures for dynamic load-carrying capacity have been calculated assuming a nominal travel of 100,000 m. For a nominal travel of 50,000 m, the 'C' figures in the table must be multiplied by a factor of 1.26.

Dimensions

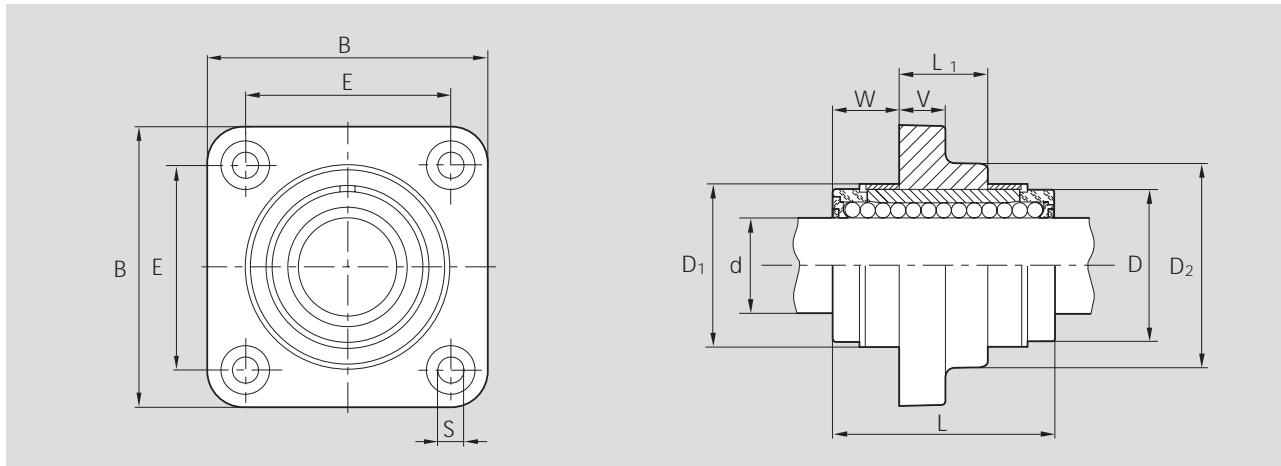

Ø d	Dimensions (mm)									
	B ¹⁾	L	L ₁	D	D ₁ ₊₁	D ₂ ¹⁾	E	S _{H13}	V ¹⁾	W
12	42	32	12	22	24	28	30±0.12	5.5	6	10
16	50	36	15	26	28.5	34	35±0.12	5.5	8	10.5
20	60	45	18	32	35	42	42±0.15	6.6	10	13.5
25	74	58	23	40	43	54	54±0.15	6.6	12	17.5
30	84	68	26	47	49.5	62	60±0.25	9.0	14	21
40	108	80	36	62	66.5	80	78±0.25	11	16	22
50	130	100	72	75	81	98	98±0.25	11	18	14

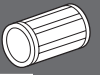

Ø d (mm)	Radial clearance (µm)		Load capacities ²⁾ (N)	
	shaft		dyn.	stat.
	h6	h7	C	C ₀
12	+38 +10	+43 +12	770	420
16	+38 +10	+43 +12	940	530
20	+43 +11	+49 +13	1860	1050
25	+43 +11	+49 +13	3640	2180
30	+43 +11	+49 +13	4420	2790
40	+50 +12	+57 +14	7590	4350
50	+50 +12	+57 +14	11100	6470

¹⁾ Tolerance to DIN 1686-GTB 15.

²⁾ The load capacities stated are minimum values as the position and direction of load cannot always be precisely defined.

STAR – Super Linear Bushings **HL** and **SH**

Super Linear Bushings **HL** and **SH** have even more load bearing plates and ball rows than the highly successful conventional version. This means more than double the dynamic load-carrying capacity – at no cost to the self-alignment feature.

Super Linear Bushings **HL** and **SH** for extremely high loads.

Super Linear Bushings **HL** and **SH** consist of:

- a one-piece polyacetal ball retainer
- hardened steel segmental load bearing plates with ground ball tracks and ground outer surfaces
- balls of antifriction bearing steel quality
- metal holding rings as sturdy end caps
- replaceable twin-lip seal rings (in the sealed version)
- seal strips (in the fully sealed, open type)

Design variants

- Closed or open types
- With or without seal rings
- With or without seal strip
- Optional screw-mounted Linear Sets (Linear Bushing with Housing) in different types
- **Super Linear Bushings **HL** and **SH** are also available with STAR-Resist corrosion protection (yellow chromated zinc-iron coating) and a special version (black chromated)**

The advantages

- High load-carrying capacity and service life
- High running speed
- Automatic compensation of alignment errors or shaft deflection
- Smooth and stutter-free running of the balls in the ball tracks
- High rigidity
- Fully sealed by seal rings and seal strips
- Good contact between steel load bearings plates and the inner surface of the mounting hole
- In-service lubrication via lubrication hole or pockets
- Greater efficiency due to retention by locating screw



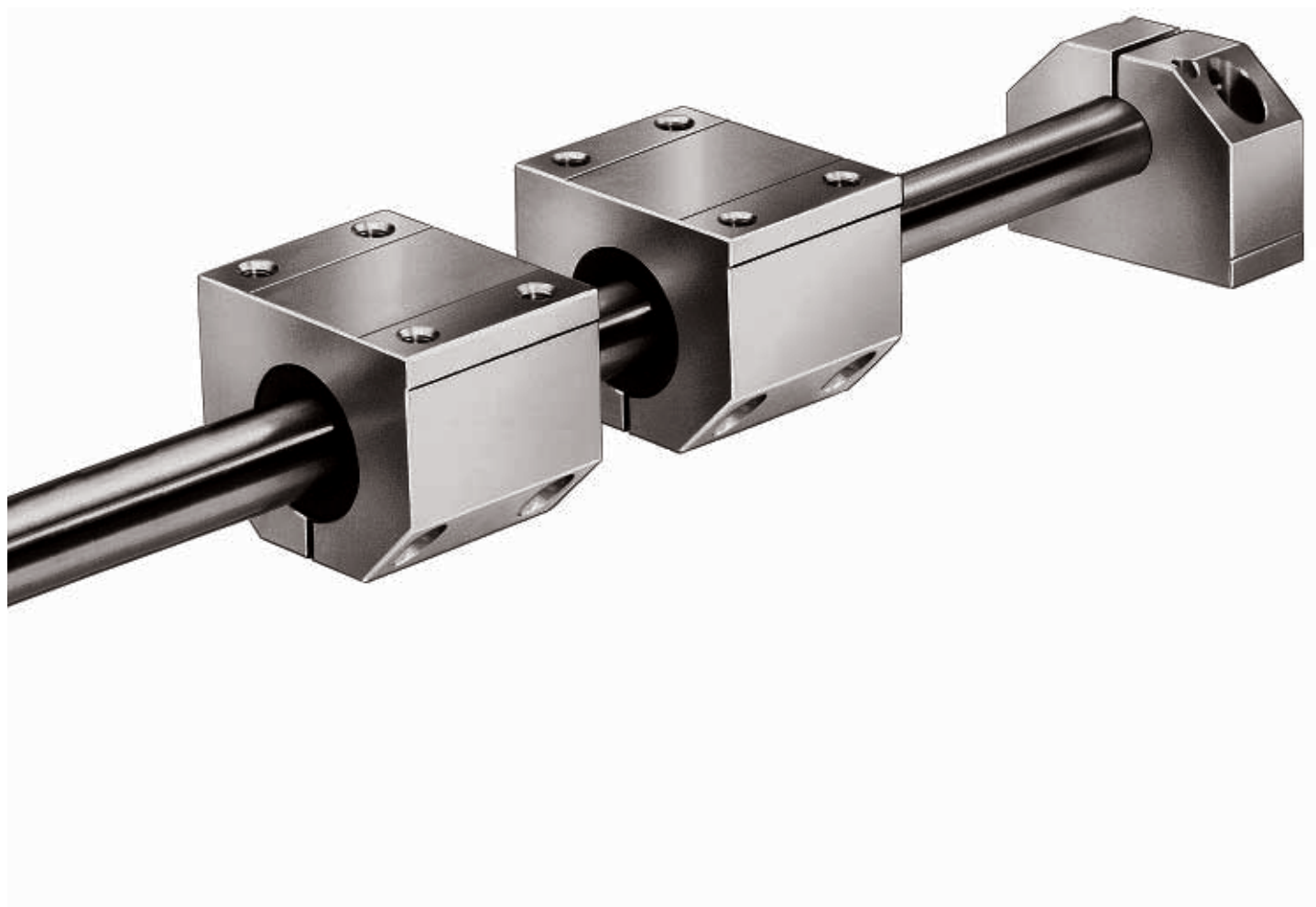

Open type

- Uniform load distribution over the open section thanks to symmetrically arranged ball tracks
- Fully sealed
- Screw-mounted metal end caps







STAR – Super Linear Bushings and

Technical Data

Please observe the general technical principles and mounting instructions at the beginning of this catalog as well as the additional technical data given below.

Dimensions/Interchangeability

Super Linear Bushings  and  have the same outside dimensions as Super Linear Bushings  and  as well as Standard Linear Bushings (caution: different retention, radial clearance, load capacity and lubrication). For this reason, all the versions are interchangeable.

Sealing

Two-fold protection through dual-action seals:

- the outer lip prevents the penetration of dirt and foreign bodies
- the inner lip prevents excessive loss of lubricant





In closed types, the seals are flexibly mounted, floating into good contact under all service conditions. The open types also have a seal strip to fully seal the gap between the ball retainer and the shaft. All seals can be replaced if necessary.

Friction

Very low friction due to the rolling friction principle. Extremely low breakaway forces. The friction μ of unsealed Super Linear Bushings using oil as a lubricant lies between 0.001 and 0.004.

The friction is lowest under high load. It may, however, be greater than the stated value when only a slight load is applied.

For Super Linear Bushings fitted at both ends with internal wiper seals and not subject to radial loading, the frictional drag (see table below) depends on the speed and the type of lubrication.

Shaft Ø d (mm)	Closed and open type Super Linear Bushings  and  with internal wiper seals		Open type Super linear bushings  and  fully sealed	
	Breakaway force (N) approx.	Frictional drag (N) approx.	Breakaway force (N) approx.	Frictional drag (N) approx.
20	5	2.5	7.5	4
25	7	3	10.5	4.5
30	9	4	13.5	6
40	12	5	18	7.5
50	15	6	22.5	9
60	18	7	27	10.5

Velocity

$v_{\max} = 5 \text{ m/s}$

Acceleration

$a_{\max} = 150 \text{ m/s}^2$

Operating temperature

up to 100 °C

Direction of load and its influence on the load-carrying capacity

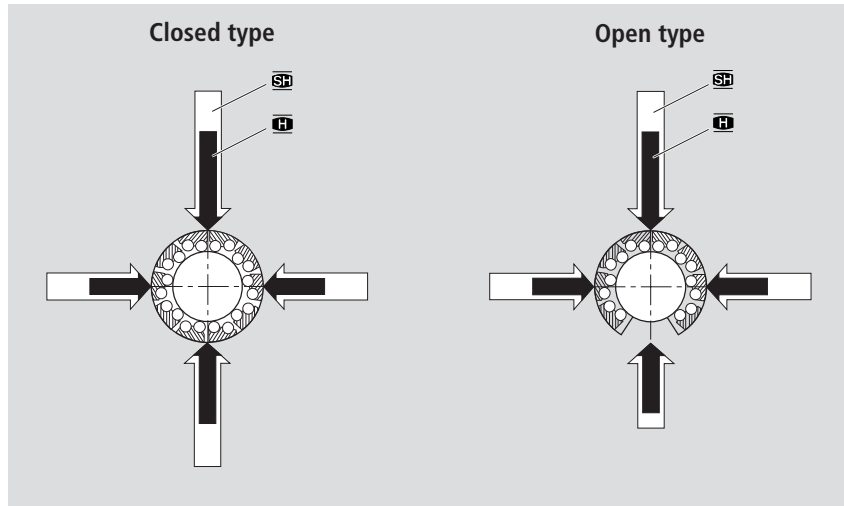

Main directions of load

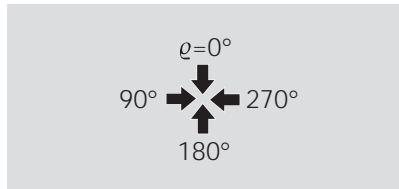

Load capacity factors

The load capacities C and C_0 apply when the load is acting along the line $\varrho = 0^\circ$. If the load is acting in any other direction, these load capacities must be multiplied by the factors f_ϱ (dynamic load capacity C) or $f_{\varrho 0}$ (static load capacity C_0).

		Load capacity factor f_ϱ											
Shaft $\varnothing d$	Super Linear Bushing \oplus						Super Linear Bushing \oplus						
	↓	→	←	↑	↓	→	←	↑	↓	→	←	↑	
20-25	1	0.80	0.98	1	0.80	0.67	1	0.79	1	1	0.79	0.52	
30-60	1	0.70	0.91	1	0.70	0.62	1	0.86	1	1	0.86	0.59	
		Load capacity factor $f_{\varrho 0}$											
20-25	1	0.70	0.87	1	0.70	0.67	1	0.68	1	1	0.68	0.50	
30-60	1	0.62	0.80	1	0.62	0.61	1	0.83	1	1	0.83	0.55	

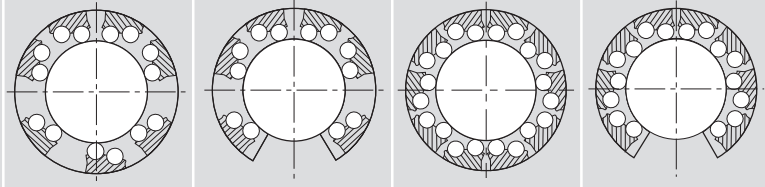

STAR – Super Linear Bushings and

Technical Data

Load capacity factors

Super Linear Bushing

Shaft diameter d 20-25

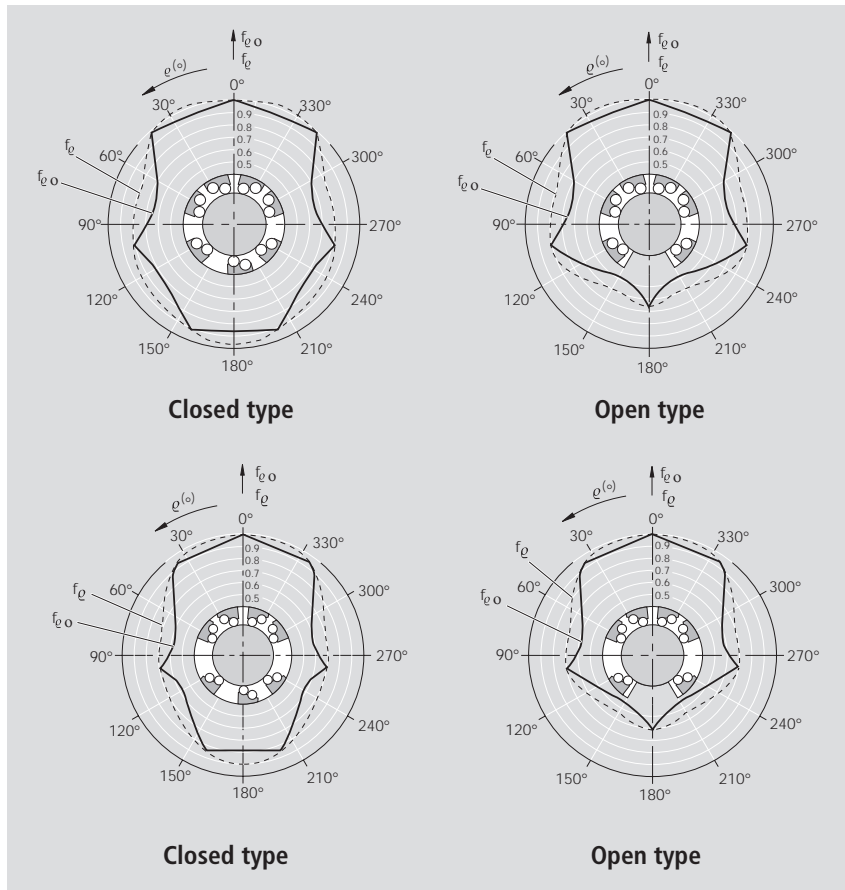

Shaft diameter d 30-60

Super Linear Bushings can be installed in any mounting position. The mounting position should be chosen so that the load acts mainly along the line $\varrho = 0^{\circ}$.

Super Linear Bushing 

Shaft diameter d 20-25

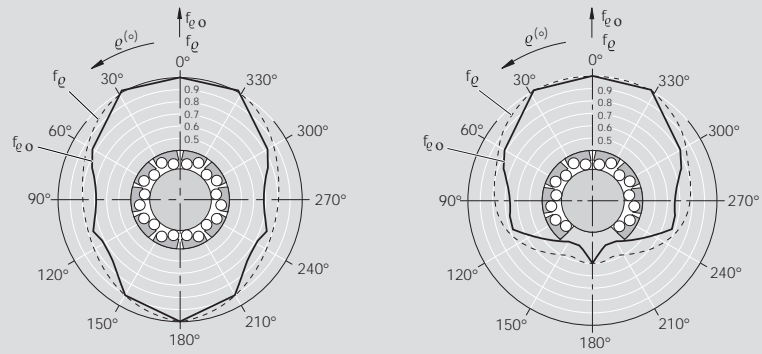

Closed type

Open type

Shaft diameter d 30-50

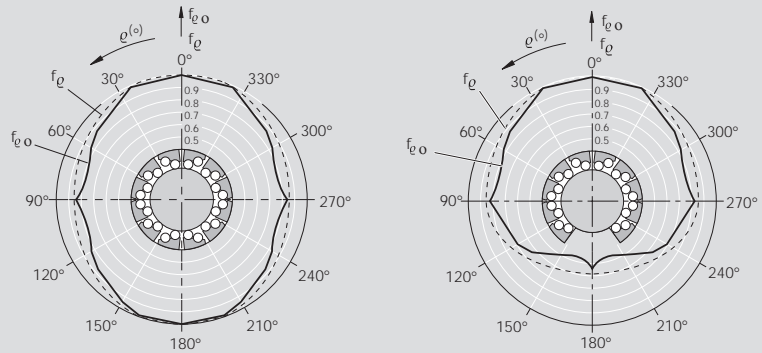

Closed type

Open type

Super Linear Bushings can be installed in any mounting position. The mounting position should be chosen so that the load acts mainly along the line $\varrho = 0^\circ$.



An indentation in the plastic ball retainer of closed Super Linear Bushing  (see magnification) indicates the main direction of load $\varrho = 0^\circ$ (maximum load capacity).

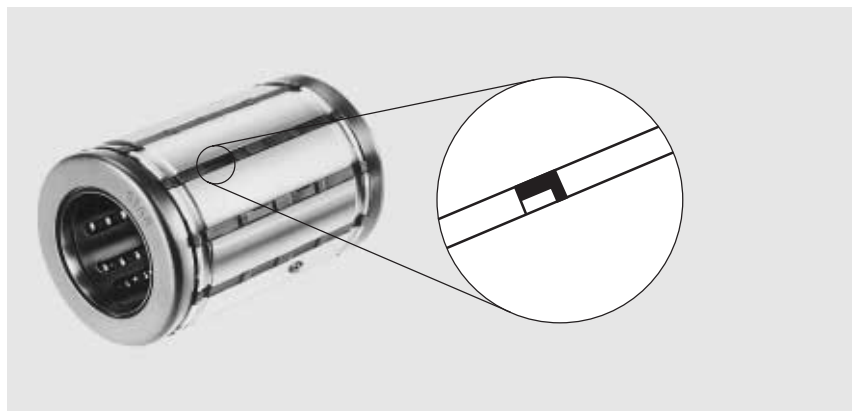

STAR – Super Linear Bushings and

Technical Data

Reduced load capacity in short-stroke applications

In short-stroke applications, the service life of the shafts is shorter than that of the Super Linear Bushings. For this reason, the load capacities C given in the tables must be multiplied by the factor f_w .

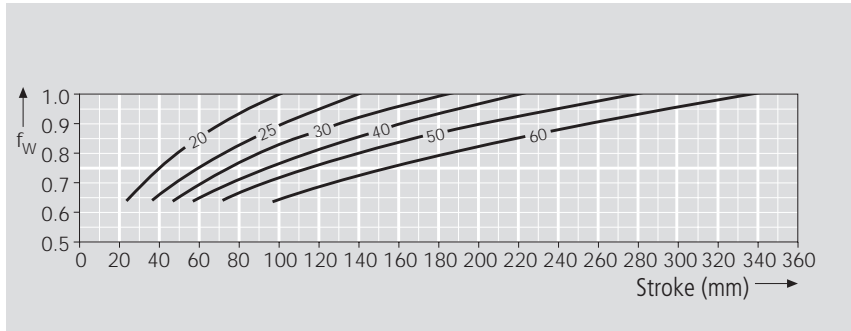

Reduced load capacity at high loads

Reduced load capacity at high loads F . The dynamic load capacity must be multiplied by the load factor f_F .

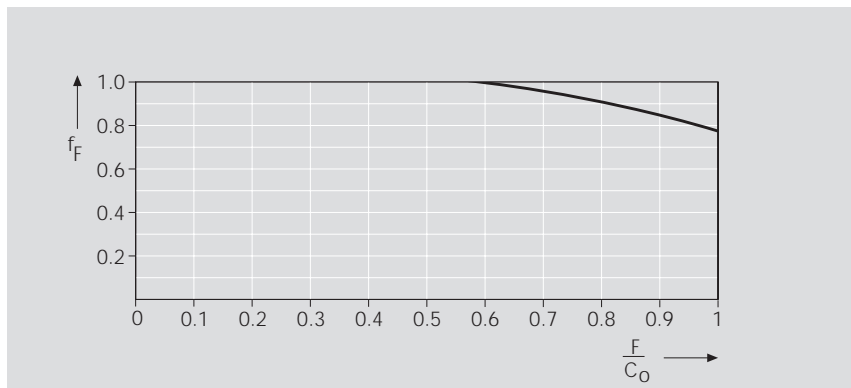

Self-alignment

Super Linear Bushings automatically compensate for alignment errors of up to 30'. No reduction in load-carrying capacity due to pressure between bushing edge and shaft.

Running speed and characteristics

High acceleration and running speed due to:

- hard-wearing ball retainer

Smooth and stutter-free running of the balls in the ball tracks due to:

- optimized track geometry at both ends
- ground ball tracks



Ground outer surfaces

The ground outer surface of the load bearing plates produces very good contact between the steel bearing plates and the inner surface of the mounting hole.

Load-carrying capacity and service life

The high number of ball tracks provides a very high load-carrying capacity and long service life.

Lubrication

In-service lubrication is possible via the lube hole in closed type  or via the grease pockets in the ball retainer in types  and .

Retention

Super Linear Bushings  and  feature simple and economical radial and axial retention by locating screw.

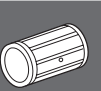

STAR – Super Linear Bushings and Customer-Built Housings

Retention

Super Linear Bushing

Retention by means of locating screw inserted through hole S_1 .

Important:

Observe position of bearing plates relative to locating screw hole S_1 .

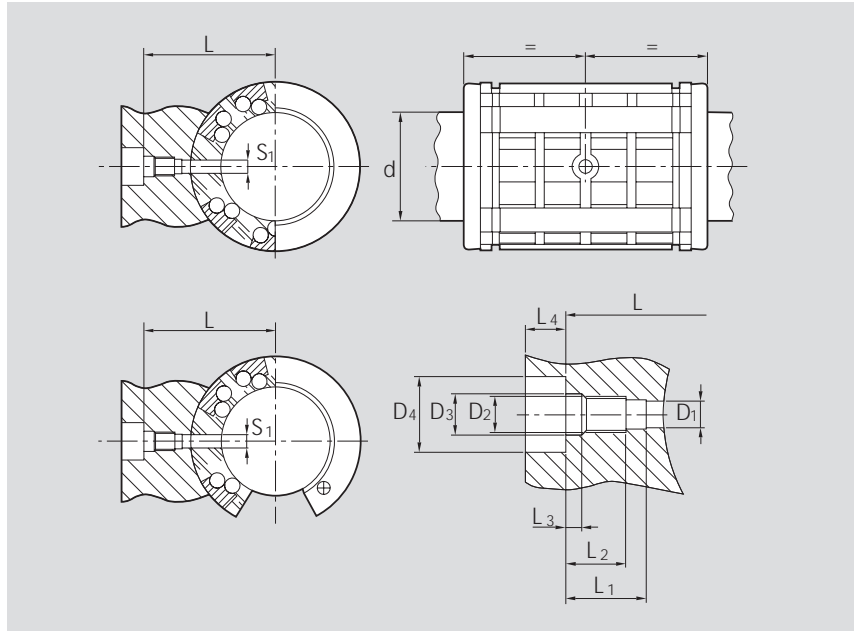

Shaft $\varnothing d$ (mm)	Dimensions (mm)										Locating screw	
	S_1	L	L_1	L_2	L_3	L_4	D_1	D_2	D_3	D_4	Part numbers	Tightening torque (Nm)
20	3	± 0.1	$+0.2$	min.	$+0.2$	min.	$+0.1$		H13	H13	8427-008-09	1.9
25	3.5	33.5	11	8.5	2.3	4	3.6	M5	5.5	10	8427-003-09	3.8
30	3.5	37	11	8.5	2.3	4	3.6	M5	5.5	10	8427-003-09	3.8
40	3.5	44.5	11	8.5	2.3	4	3.6	M5	5.5	10	8427-003-09	3.8
50	4.5	59.5	17	14	3	4.7	4.6	M6	6.6	11	8427-004-09	6.7
60	6	72.5	22	18	4	6	6.2	M8	9	15	8427-007-09	16

Super Linear Bushing

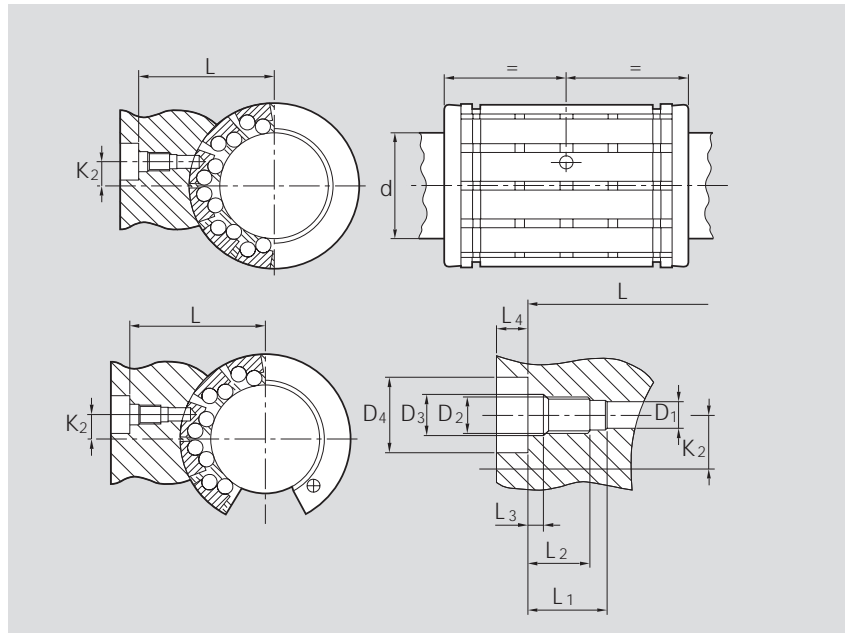

Retention by means of locating screw

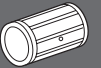

Shaft Ø d (mm)	Dimensions (mm)										Locating screw	
	L	K ₂	L ₁	L ₂	L ₃	L ₄	D ₁	D ₂	D ₃	D ₄	Part numbers	Tightening torque (Nm)
20	+0.2	1.3	+0.2	min.	+0.2	min.	+0.1	M4	4.5	8	8427-001-09	1.9
25	30.75	2	9	7	2	3.2	2.6	M4	4.5	8	8427-001-09	1.9
30	38.15	7	11	8.5	2.3	4	3.6	M5	5.5	10	8427-003-09	3.8
40	44.75	9.5	11	8.5	2.3	4	3.6	M5	5.5	10	8427-003-09	3.8
50	59.75	10	17	14	3	4.7	4.6	M6	6.6	11	8427-004-09	6.7



Locating screw

for retention of Super Linear Bushings  and 

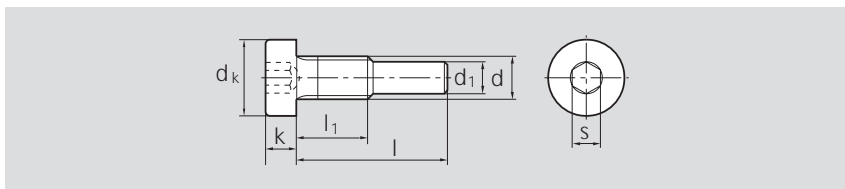

d	Dimensions (mm)						Locating screw	
	dk	d ₁	l	l ₁	k	s	Part numbers	Tightening torque (Nm)
M4	7	2.5	12	6.3	2.8	2.5	8427-001-09	1.9
M4	7	3	14.1	6.5	2.8	2.5	8427-008-09	1.9
M5	8.5	3.5	17	8	3.5	3	8427-003-09	3.8
M6	10	4.5	26	13.5	4	4	8427-004-09	6.7
M8	13	6	33	17	5	5	8427-007-09	16

All other dimensions to DIN 7984.

STAR – Super Linear Bushings **H** and **SH** Customer-Built Housings

Lubrication and retention

Super Linear Bushing **H** (closed type)

Lubrication and retention by means of hollow screw inserted through hole S_1 . Dimensions given here are for customer-built housings.

Important:

Observe the position of load bearing plates relative to hole S_1 .

The lubrication channels shown here have been designed for lubrication with grease. If oil is used instead, check whether all anti-friction bearings are being properly lubricated.

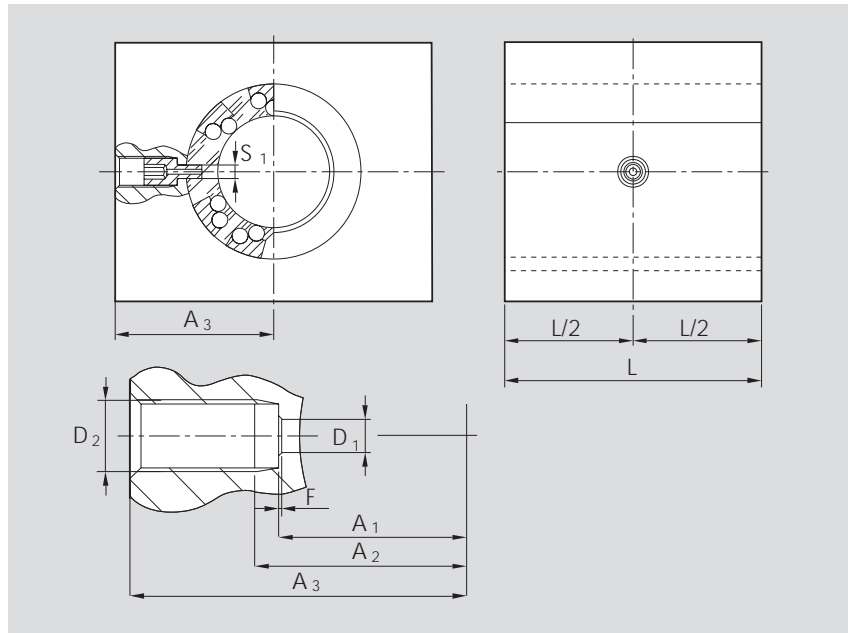

Linear Bushing Part Number H	Dimensions (mm)								Hollow screw	
	S_1	L min.	D_1 +0.1	D_2	A_1 ± 0.1	A_2 max.	A_3 min.	F	Part numbers	Tightening torque (Nm)
0732-220-40	3	46	3.1	M8x1	18.5	20.5	31	0.3x45°	8432-010-00	5.5
0732-225-40	3.5	59	3.6	M8x1	22.5	25	38	0.3x45°	8432-007-00	5.5
0732-230-40	3.5	69	3.6	M8x1	26	28.5	41.5	0.3x45°	8432-007-00	5.5
0732-240-40	3.5	81	3.6	M8x1	33.5	36	49	0.3x45°	8432-007-00	5.5
0732-250-40	4.5	101	4.6	M8x1	42	44.5	59	0.3x45°	8432-008-00	5.5
0732-260-40	6	126	6.2	M10x1	51	53.5	71.5	0.3x45°	8432-009-00	9.5

Hollow screw

for lubrication and retention of Super Linear Bushing **H** (closed type) through hole S_1

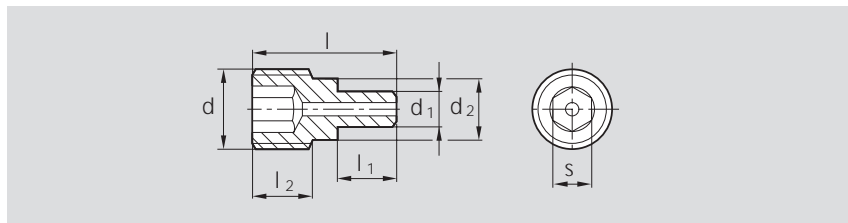

Dimensions (mm)							Hollow screw	
d	d_1	d_2	l	l_1	l_2	s	Part numbers	Tightening torque (Nm)
M8x1	3	6.5	10.5	5	3.5	4	8432-010-00	5.5
M8x1	3.5	6.5	14.5	6	5.6	4	8432-007-00	5.5
M8x1	4.5	6.5	18	8	7	4	8432-008-00	5.5
M10x1	6	8.5	25	11.5	10.2	5	8432-009-00	9.5

Lubrication

Super Linear Bushing (closed type)

Lubrication duct, ring groove and threaded lube port for lubrication with grease.
Dimensions given for customer-built housing.

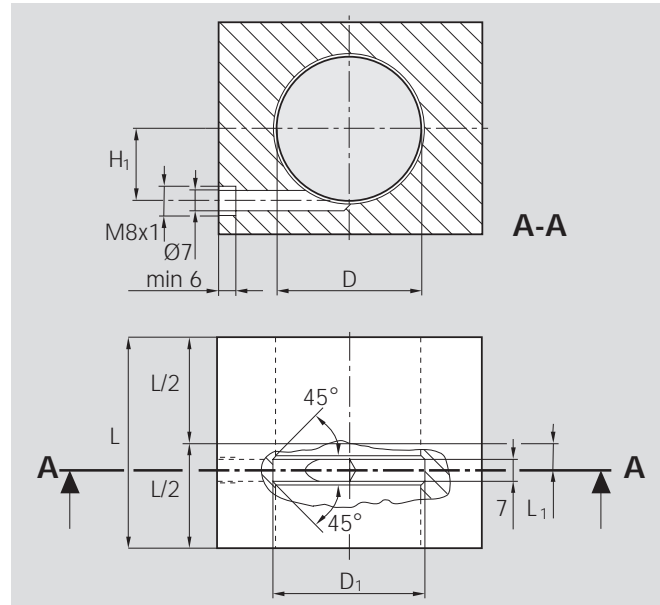

Linear Bushing	Dimensions (mm)				
Part numbers 	D	L	L ₁	H ₁	D ₁
		min.	+0.5		±0.2
0730-220-40	32	46	7	16	34
0730-225-40	40	59	8.5	20	42
0730-230-40	47	69	8.5	23.5	50
0730-240-40	62	81	10.5	31	66
0730-250-40	75	101	11.5	37.5	79

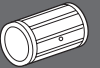
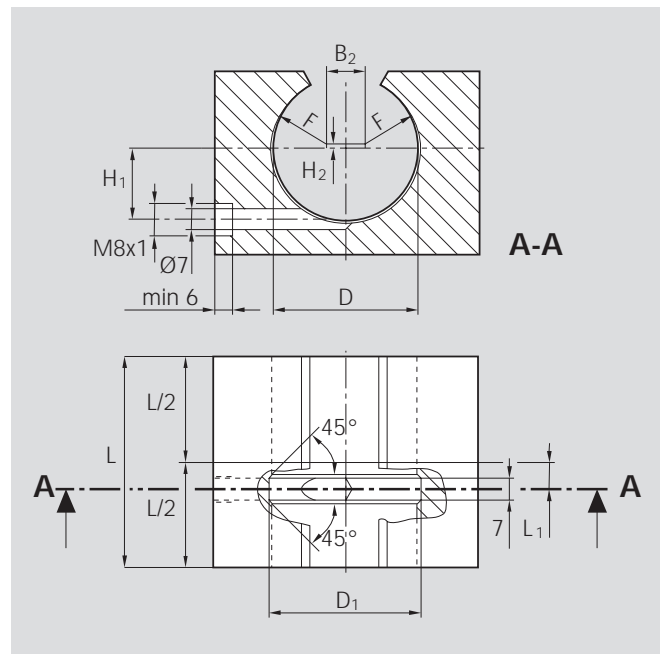

Super Linear Bushings and (open type)

Lubrication duct, ring groove and threaded lube port for lubrication with grease.
Dimensions given for customer-built housing.



Linear Bushings		Dimensions (mm)							
Part numbers 	Part numbers 	D	L	L ₁	H ₁	D ₁	B ₂	H ₂	F
			min.	+0.5		±0.2			
0733-220-45	0731-220-45	32	46	7	16	34	8	-	R13
0733-225-45	0731-225-45	40	59	8.5	20	42	11.9	0.5	R15
0733-230-45	0731-230-45	47	69	8.5	23.5	49	12.8	1	R18
0733-240-45	0731-240-45	62	81	10.5	31	66	19.9	1.1	R23
0733-250-45	0731-250-45	75	101	11.5	37.5	79	22.6	2	R28
0733-260-45	-	90	126	13	45	94	30.8	3	R31.5

STAR – Super Linear Bushings

Super Linear Bushing, 0732-
closed type

Super Linear Bushing, 0733-
open type

Structural Design

- POM ball retainer
- Hardened steel segmental load bearing plates with ground ball tracks and ground outer surfaces
- Two metal holding rings
- With or without twin-lip seal rings
- With or without axial seal strip.

For precise values for the 4 main directions of load see "Technical Data – Load capacity factors".

Ordering data



Closed type



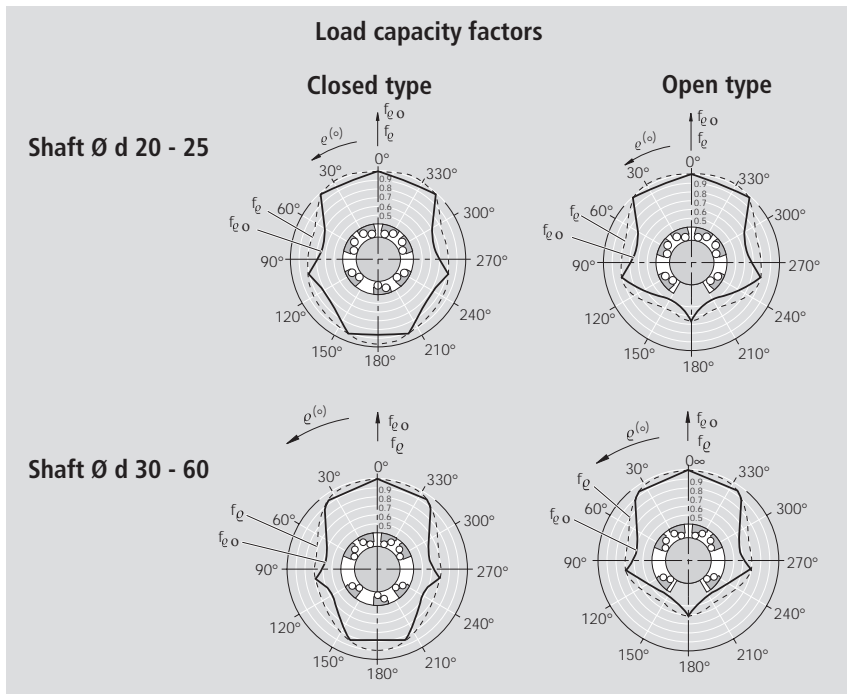

With one seal ring:
0732-1..-40 or 0733-1..-40

Open type





Shaft Ø d (mm)	Part numbers		Mass (kg)
	without seals	with two seals	
20	0732-020-00	0732-220-40	0.070
25	0732-025-00	0732-225-40	0.150
30	0732-030-00	0732-230-40	0.210
40	0732-040-00	0732-240-40	0.400
50	0732-050-00	0732-250-40	0.700
60	0732-060-00	0732-260-40	1.200
			

Shaft Ø d (mm)	Part numbers			Mass (kg)
	without seals	with two seals	fully sealed	
20	0733-020-00	0733-220-40	0733-220-45	0.060
25	0733-025-00	0733-225-40	0733-225-45	0.130
30	0733-030-00	0733-230-40	0733-230-45	0.180
40	0733-040-00	0733-240-40	0733-240-45	0.350
50	0733-050-00	0733-250-40	0733-250-45	0.600
60	0733-060-00	0733-260-40	0733-260-45	1.000
				

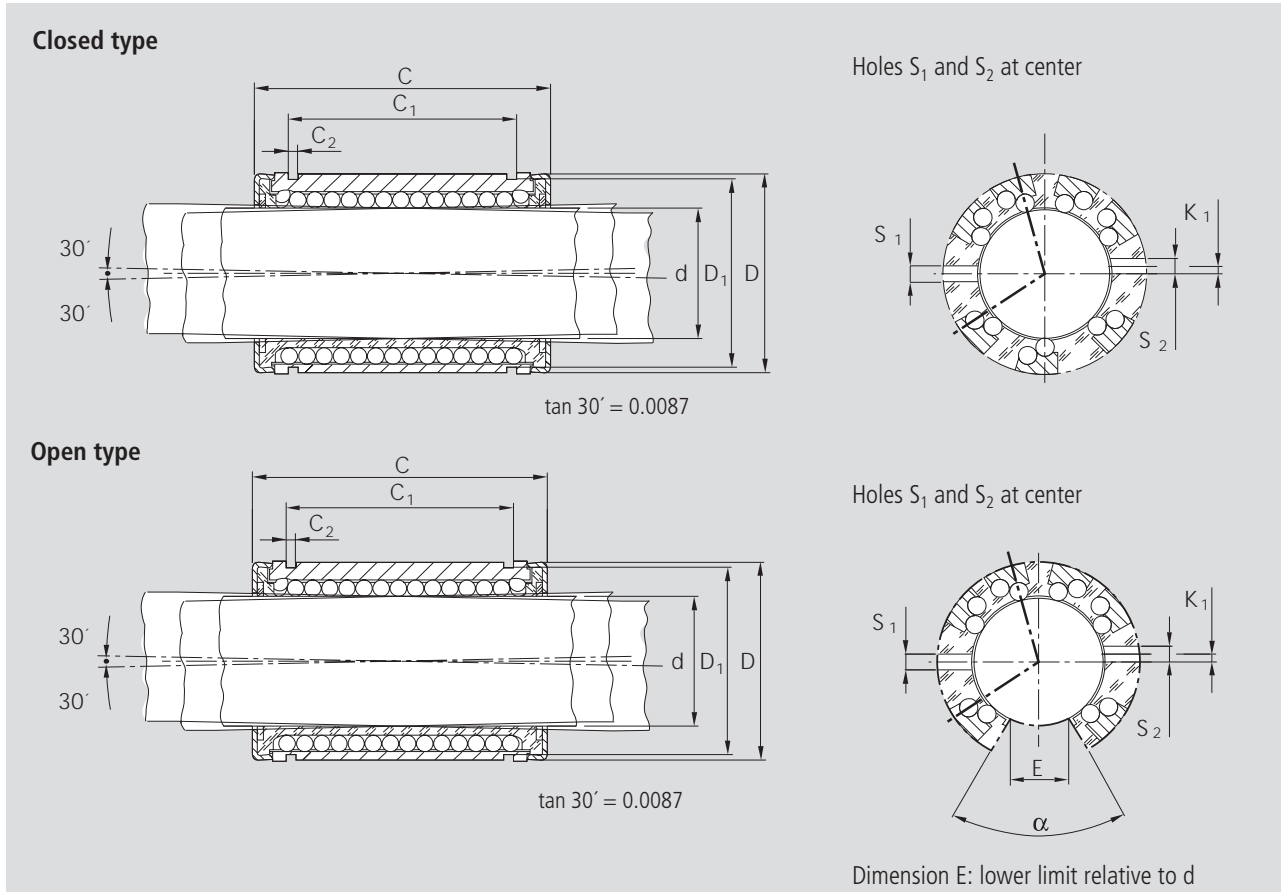
Dimensions



$\varnothing d$	Dimensions (mm)										No. of ball circuits		Angle (°) α	Radial clearance (μm)				Load capacity ¹⁾ (N)	
	D	C	C_1	C_2	D_1	S_1	S_2	K_1	E			shaft/bore				C	C_0		
	h13	H13				+0.1	+0.1		h7/H7			h7/JS7		h6/JS6	h6/K6				
20	32	45	31.2	1.6	30.5	3.0	-	-	9.5	7	6	60	+49 +13	+37 0	+28 +1	+23 -4	2520	1880	
25	40	58	43.7	1.85	38.5	3.5	3	-1.5	12	7	6	60	+49 +13	+37 0	+28 +1	+23 -4	4430	3360	
30	47	68	51.7	1.85	44.5	3.5	3	2	12.8	7	6	60	+49 +13	+37 0	+28 +1	+23 -4	6300	5230	
40	62	80	60.3	2.15	59	3.5	3	1.5	16.8	7	6	60	+57 +14	+42 -1	+31 +1	+25 -4	9680	7600	
50	75	100	77.3	2.65	72	4.5	5	2.5	22.1	7	6	60	+57 +14	+42 -1	+31 +1	+25 -4	16000	12200	
60	90	125	101.3	3.15	86.5	6.0	-	-	27	7	6	60	+65 +16	+47 -1	+34 +1	+27 -6	23500	18700	

¹⁾ The figures given for load capacity are maximum values as the position and load direction can be precisely defined.

The figures for dynamic load-carrying capacity have been calculated assuming a nominal travel of 100,000 m. For a nominal travel of 50,000 m, the 'C' figures in the table must be multiplied by a factor of 1.26.

STAR – Super Linear Bushings

Super Linear Bushings, 0730- closed type

Super Linear Bushings, 0731- open type

Structural Design

- Polyacetal ball retainer
- Hardened steel segmental load bearing plates with ground ball tracks and ground outer surfaces
- Two metal holding rings
- With or without twin-lip seal rings
- With or without axial seal strip.

For precise values for the 4 main directions of load see "Technical Data – Load capacity factors".

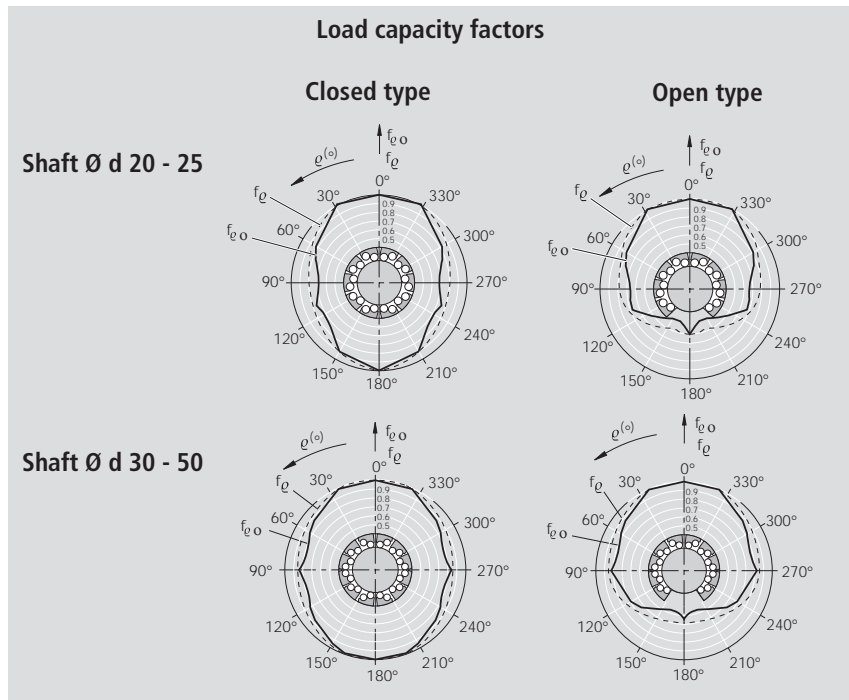





Ordering data



With one seal ring:
0730-1..-40 or 0731-1..-40



Shaft Ø d (mm)	Part numbers		Mass (kg)
	without seals	with two seals	
20	0730-020-00	0730-220-40	0.090
25	0730-025-00	0730-225-40	0.190
30	0730-030-00	0730-230-40	0.300
40	0730-040-00	0730-240-40	0.600
50	0730-050-00	0730-250-40	1.050
			

Shaft Ø d (mm)	Part numbers			Mass (kg)
	without seals	with two seals	fully sealed	
20	0731-020-00	0731-220-40	0731-220-45	0.075
25	0731-025-00	0731-225-40	0731-225-45	0.160
30	0731-030-00	0731-230-40	0731-230-45	0.250
40	0731-040-00	0731-240-40	0731-240-45	0.500
50	0731-050-00	0731-250-40	0731-250-45	0.900
				

Dimensions

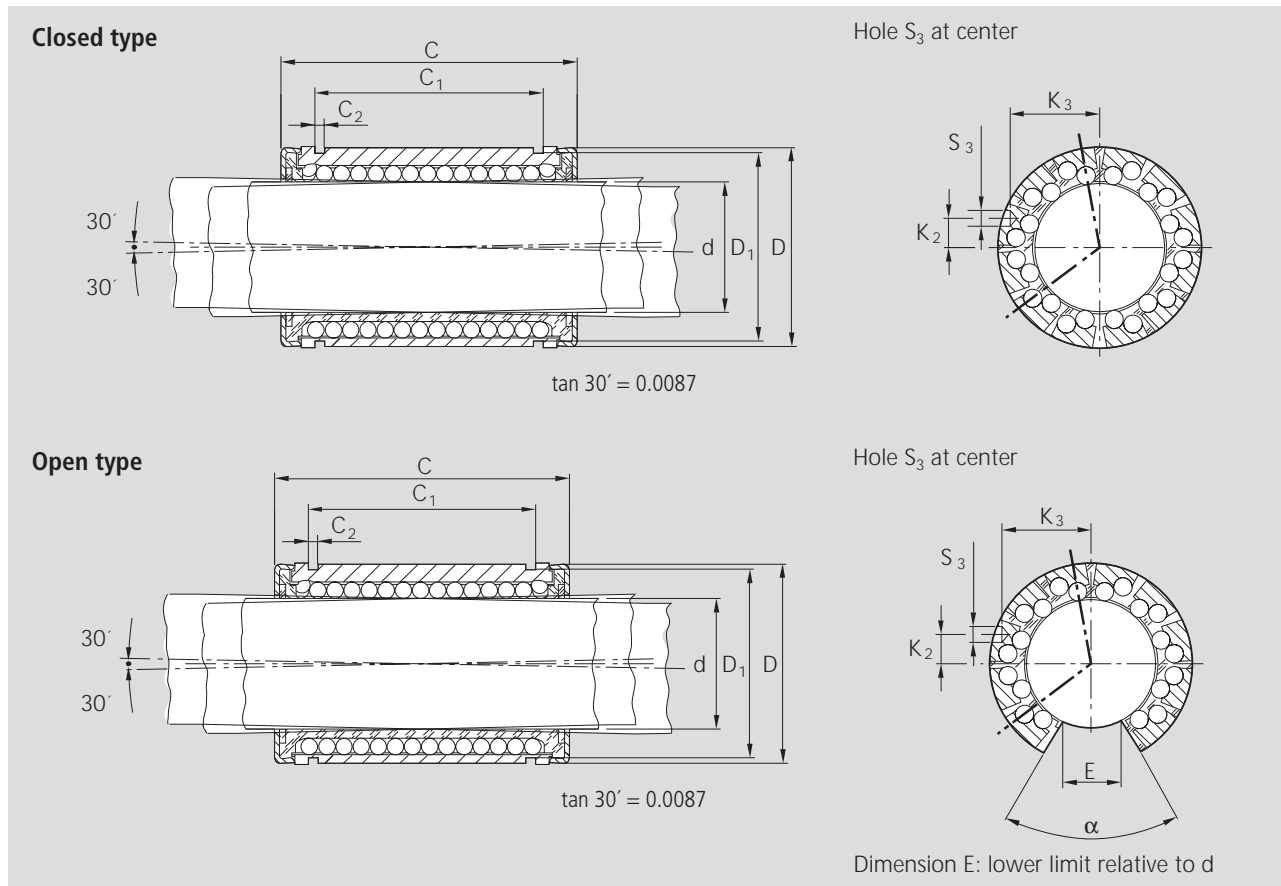

$\emptyset d$	Dimensions (mm)										No. of ball circuits		Angle ($^\circ$) α	Radial clearance (μm)				Load capacity ¹⁾ (N)	
	D	C	C_1	C_2	D_1	S_3	K_2	K_3	E			shaft/bore				dyn.	stat.		
	h13	H13				+0.1						h7/H7		h7/JS7	h6/JS6	h6/K6	C	C_0	
20	32	45	31.2	1.6	30.5	2.6	1.3	14.7	9.5	10	8	60	+49 +13	+37 0	+28 +1	+23 -4	3530	2530	
25	40	58	43.7	1.85	38.5	2.6	2	18.5	12	10	8	60	+49 +13	+37 0	+28 +1	+23 -4	6190	4530	
30	47	68	51.7	1.85	44.5	3.6	7	21	12.8	12	10	60	+49 +13	+37 0	+28 +1	+23 -4	8800	7180	
40	62	80	60.3	2.15	59	3.6	9.5	27.5	16.8	12	10	60	+57 +14	+42 -1	+31 +1	+25 -4	13500	10400	
50	75	100	77.3	2.65	72	4.6	10	33.5	22.1	12	10	60	+57 +14	+42 -1	+31 +1	+25 -4	22300	16800	

¹⁾ The figures given for load capacity are maximum values as the position and load direction can be precisely defined.

The figures for dynamic load-carrying capacity have been calculated assuming a nominal travel of 100,000 m. For a nominal travel of 50,000 m, the 'C' figures in the table must be multiplied by a factor of 1.26.

STAR – Linear Sets with Super Linear Bushings **H** or **SH**

Technical Data

Tolerances, parallelism of guideway in service

Linear Sets 1703-, 1704- with shaft support rail 1050- and shaft

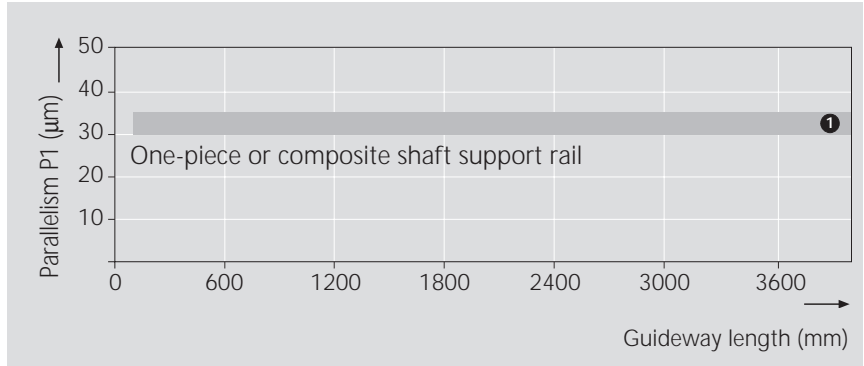

Linear Sets 1703-, 1704- with shaft support rail 1016- and shaft

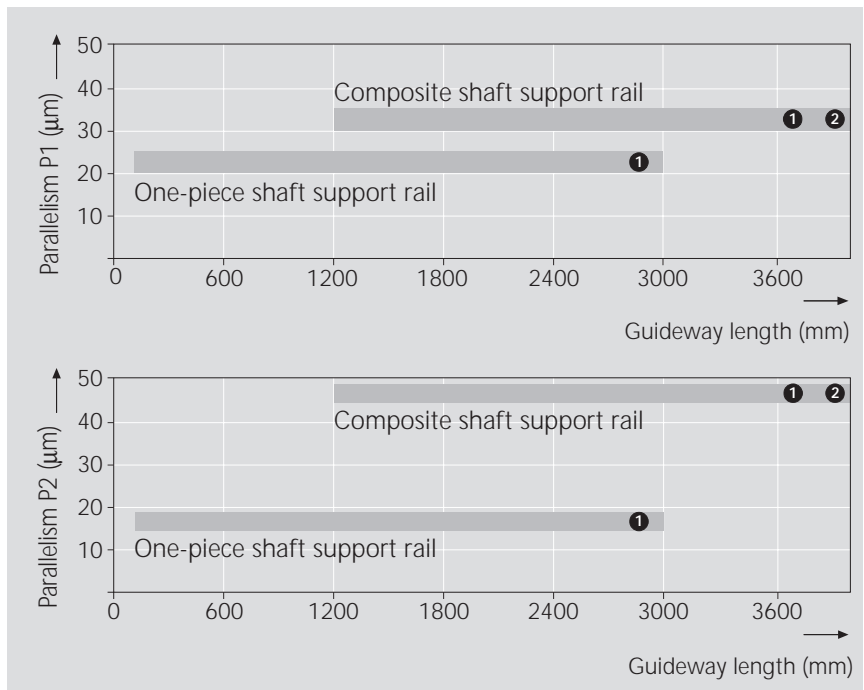

Linear Sets 1706- with shaft support rail 1054- and shaft

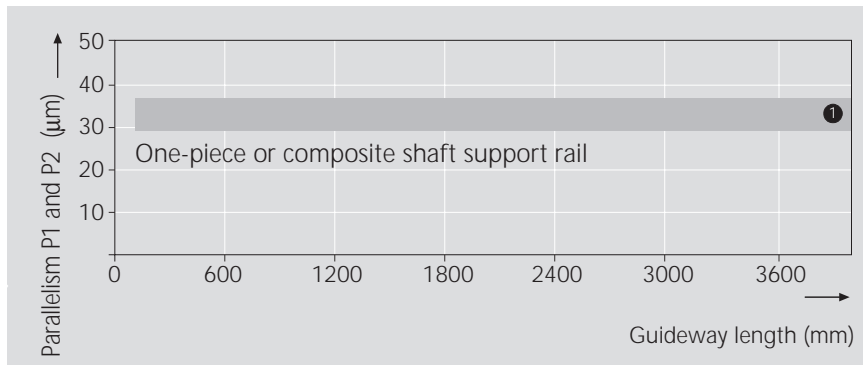

For precise values see "Tolerances" table
 ⚠ Composite shaft support rail made up of several sections of the same grade

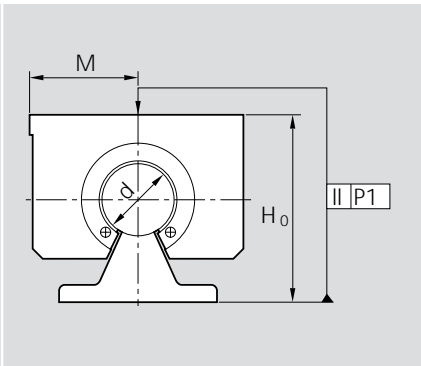

Tolerances (µm)		Shaft Ø d (mm)				
Set with shaft and shaft support rail (WU)		Tolerance zone of shaft				
			20	30	40	60
Dimension H₀	Ã	h6	+18 -39	+18 -39	+18 -42	+18 -45
		h7	+18 -47	+18 -47	+18 -51	+18 -56
Parallelism P1	Ö	h6	30	30	32	33
		h7	32	32	35	35

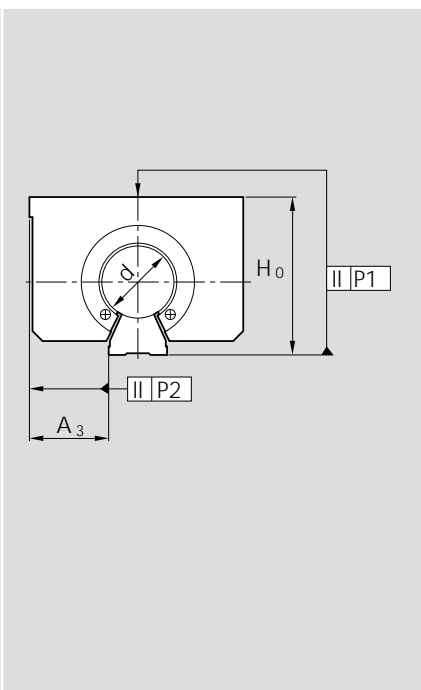

Tolerances (µm)		Shaft Ø d (mm)					
Set with shaft and shaft support rail (WU)		Tolerance zone of shaft					
			20	25	30	40	50
Dimension H₀ several WUs	Ã	h6	+28 -69	+28 -69	+28 -69	+28 -72	+28 -72
		h7	+28 -77	+28 -77	+28 -77	+28 -81	+28 -81
Dimension H₀ one WU	Ã	h6	57	57	57	60	60
		h7	65	65	65	67	69
Parallelism P1 several WUs	Ö Æ	h6	30	30	30	32	32
		h7	32	32	32	35	35
Parallelism P1 one WU	Ö	h6	20	20	20	22	22
		h7	22	22	22	25	25
Parallelism P2 several WUs	Ö Æ	h6	45	45	45	46	46
		h7	46	46	46	48	48
Parallelism P2 one WU	Ö	h6	15	15	15	16	16
		h7	16	16	16	18	18
Dimension A₃	Ã	h6	+30 -37	+30 -37	+30 -37	+30 -38	+30 -38
		h7	+30 -41	+30 -41	+30 -41	+30 -43	+30 -43

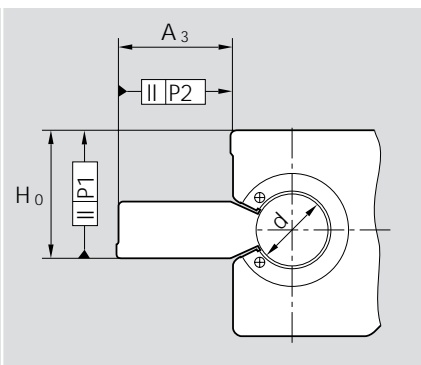
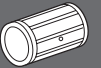

Tolerances (µm)		Shaft Ø d (mm)					
Set with shaft and shaft support rail (WU)		Tolerance zone of shaft					
			20	25	30	40	50
Dimension H₀	Ã	h6	+20 -35	+20 -35	+20 -35	+20 -36	+20 -36
		h7	+20 -39	+20 -39	+20 -39	+20 -41	+20 -41
Dimension A₃	Ã	h6	+20 -33	+20 -33	+20 -33	+21 -37	+21 -37
		h7	+20 -41	+20 -41	+20 -41	+21 -46	+21 -46
Parallelism P1	Ö	h6	29	29	29	30	30
		h7	30	30	30	32	32
Parallelism P2	Ö	h6	29	29	29	34	34
		h7	31	31	31	37	37

Maximum difference between dimensions:

H₀ = 24 µm,

M = 20 µm,

A₃ = 20 µm.

Measured at center of housing at same position on shaft.

Ã measured at center of housing

Ö when screwed to base mounting surface

STAR – Linear Sets with Super Linear Bushings **HL** or **SH**

Linear Sets, 1701-closed type

Linear Sets, 1702-adjustable

Structural Design

- Precision Housing (aluminum)
- Super Linear Bushing **HL** or **SH**
- Fully sealed
- Retention by means of screw
- Lubricatable

For precise values for the 4 main directions of load see "Technical Data – Load capacity factors".

The figures for dynamic load-carrying capacity have been calculated assuming a nominal travel of 100,000 m.

For a nominal travel of 50,000 m, the 'C' figures in the table on the opposite page must be multiplied by a factor of 1.26.

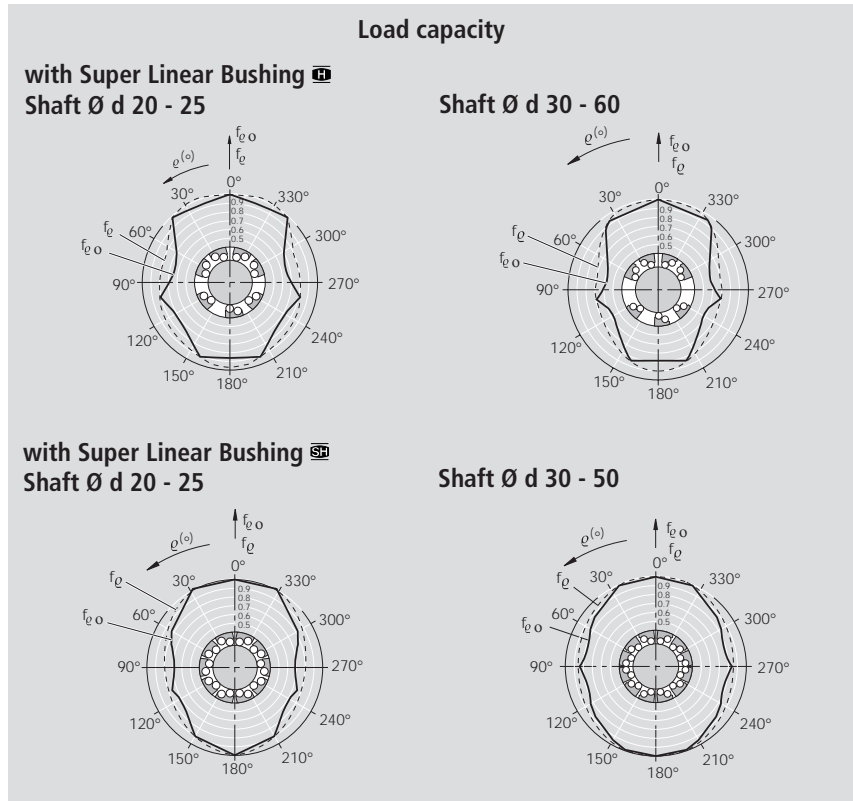

Ordering data



Shaft Ø d (mm)	Part numbers with Super Linear Bushing		Mass (kg) with Super Linear Bushing	
	HL	SH	HL	SH
20	1701-220-20	1701-420-20	0.29	0.31
25	1701-225-20	1701-425-20	0.58	0.63
30	1701-230-20	1701-430-20	0.88	0.97
40	1701-240-20	1701-440-20	1.63	1.86
50	1701-250-20	1701-450-20	2.70	3.10
60	1701-260-20	–	5.20	–



Shaft Ø d (mm)	Part numbers with Super Linear Bushing		Mass (kg) with Super Linear Bushing	
	HL	SH	HL	SH
20	1702-220-20	1702-420-20	0.29	0.31
25	1702-225-20	1702-425-20	0.58	0.63
30	1702-230-20	1702-430-20	0.88	0.97
40	1702-240-20	1702-440-20	1.63	1.86
50	1702-250-20	1702-450-20	2.70	3.10
60	1702-260-20	–	5.20	–



Dimensions

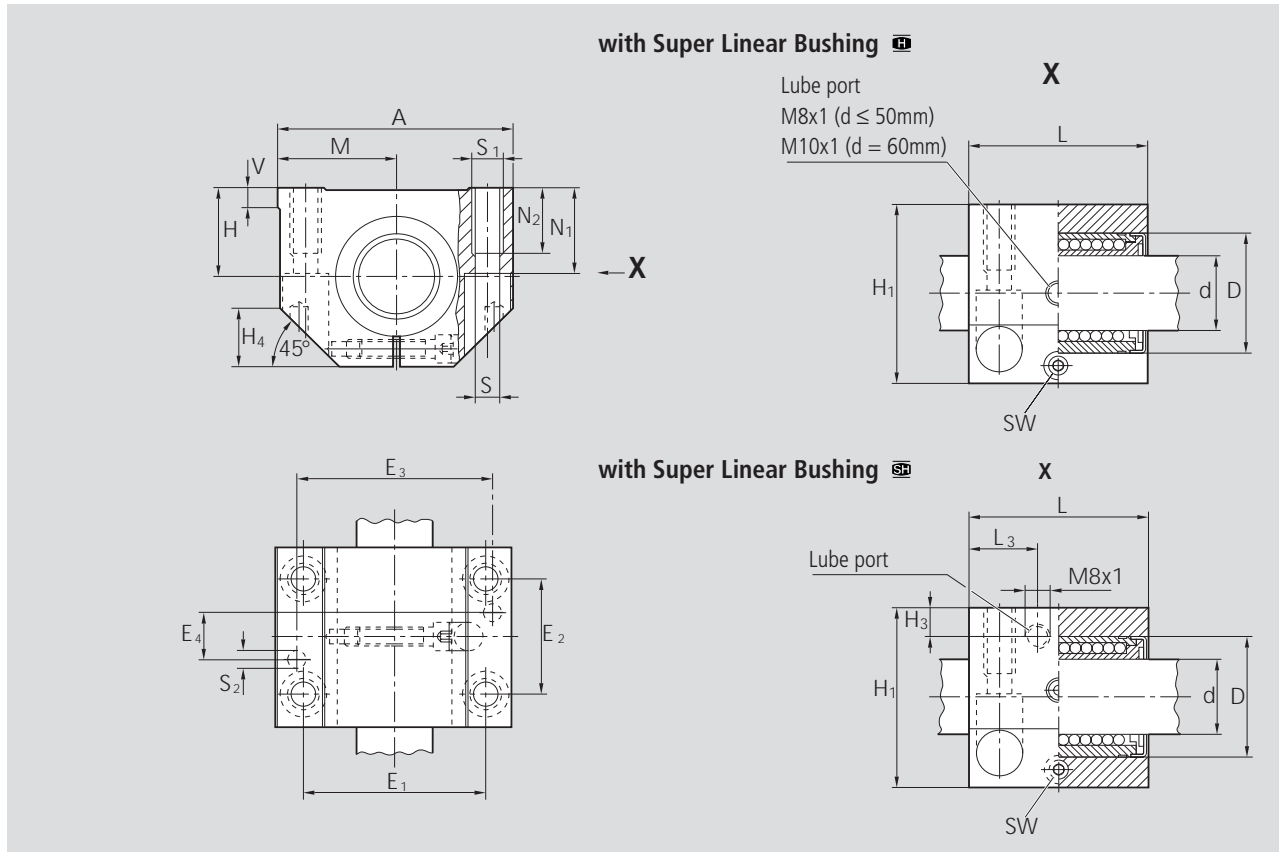

Dimensions (mm)																				
Ø d	D	H ¹⁾ +0.008 -0.016	H ₁	M ¹⁾ ±0.01	A	L	E ₁	E ₂	E ₃	E ₄	S	S ₁	S ₂	N ₁	N ₂	H ₃	L ₃	V	SW	H ₄
20	32	25	50	30	60	46	45±0.15	32±0.15	50	15	6.6	M8	5	24	18	10	16	5	4	16
25	40	30	60	39	78	59	60±0.15	40±0.15	64	17	8.4	M10	6	29	22	10	21	6.5	5	20
30	47	35	70	43.5	87	69	68±0.15	45±0.15	72	20	8.4	M10	6	34	22	11.5	26	8	5	22
40	62	45	90	54	108	81	86±0.15	58±0.15	90	25	10.5	M12	8	44	26	14	30	10	6	28
50	75	50	105	66	132	101	108±0.20	50±0.20	108	35	13.5	M16	10	49	34	12.5	39	12	8	37
60	90	60	125	82	164	126	132±0.20	65±0.20	132	108	17.5	M20	12	59	42	-	-	13	10	45

Ø d (mm)	Radial clearance (µm) ²⁾		adjusted prior to delivery to zero clearance on h5 shaft (lower limit)	Load capacity (N) ³⁾ with Super Linear Bushing			
	1701- Shaft			H		SP	
	h6	h7		C	C ₀	C	C ₀
20	+43 +11	+49 +13		2520	1880	3530	2530
25	+43 +11	+49 +13		4430	3360	6190	4530
30	+43 +11	+49 +13		6300	5230	8800	7180
40	+50 +12	+57 +14		9680	7600	13500	10400
50	+50 +12	+57 +14		16000	12200	22300	16800
60	+56 +14	+65 +16		23500	18700	-	-

- 1) When screwed down, relative to shaft nominal dimension d.
- 2) When screwed down.
- 3) Caution:
Reduction in load capacity due to load direction (see "Technical Data").
The figures given for load capacity are maximum values as the position and load direction can be precisely defined.

STAR – Linear Sets with Super Linear Bushings **HL** or **SH**

Linear Sets, 1703-
open type

Linear Sets, 1704-
open type, adjustable

Structural Design

- Precision Housing (aluminum)
- Super Linear Bushing **HL** or **SH**
- Fully sealed
- Retention by means of screw
- Lubricatable

For precise values for the 4 main directions of load see "Technical Data – Load capacity factors".

The figures for dynamic load-carrying capacity have been calculated assuming a nominal travel of 100,000 m.

For a nominal travel of 50,000 m, the 'C' figures in the table on the opposite page must be multiplied by a factor of 1.26.

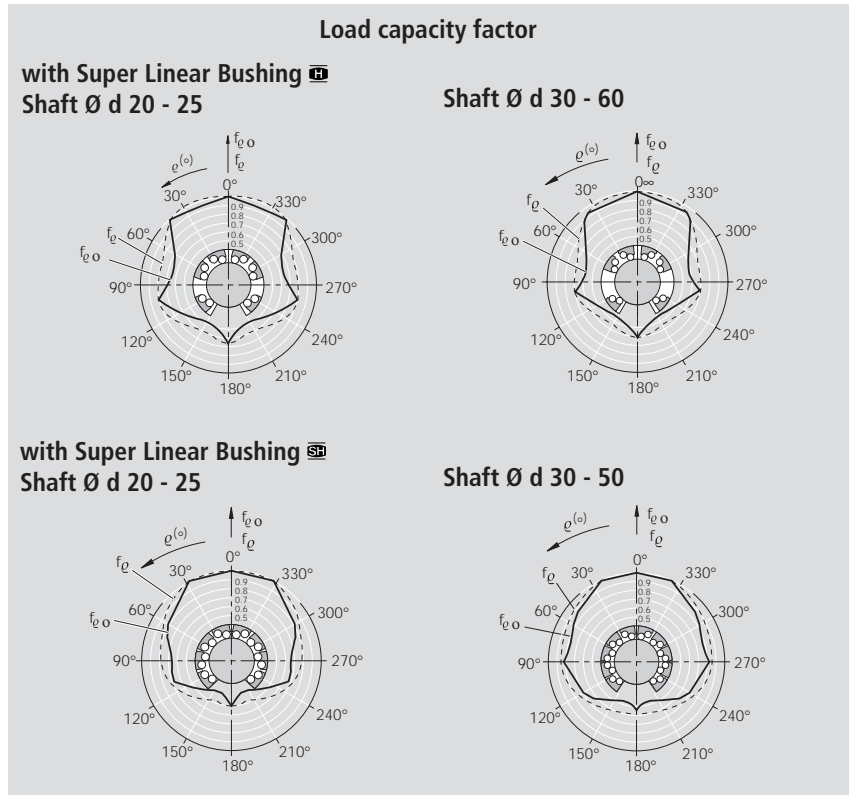

Ordering data

open type



Shaft Ø d (mm)	Part numbers with Super Linear Bushing		Mass (kg) with Super Linear Bushing	
	HL	SH	HL	SH
20	1703-220-70	1703-420-70	0.24	0.26
25	1703-225-70	1703-425-70	0.48	0.51
30	1703-230-70	1703-430-70	0.72	0.79
40	1703-240-70	1703-440-70	1.38	1.56
50	1703-250-70	1703-450-70	2.30	2.60
60	1703-260-70	–	4.40	–

open type, adjustable



Shaft Ø d (mm)	Part numbers with Super Linear Bushing		Mass (kg) with Super Linear Bushing	
	HL	SH	HL	SH
20	1704-220-70	1704-420-70	0.24	0.26
25	1704-225-70	1704-425-70	0.48	0.51
30	1704-230-70	1704-430-70	0.72	0.79
40	1704-240-70	1704-440-70	1.38	1.56
50	1704-250-70	1704-450-70	2.30	2.60
60	1704-260-70	–	4.40	–

Dimensions

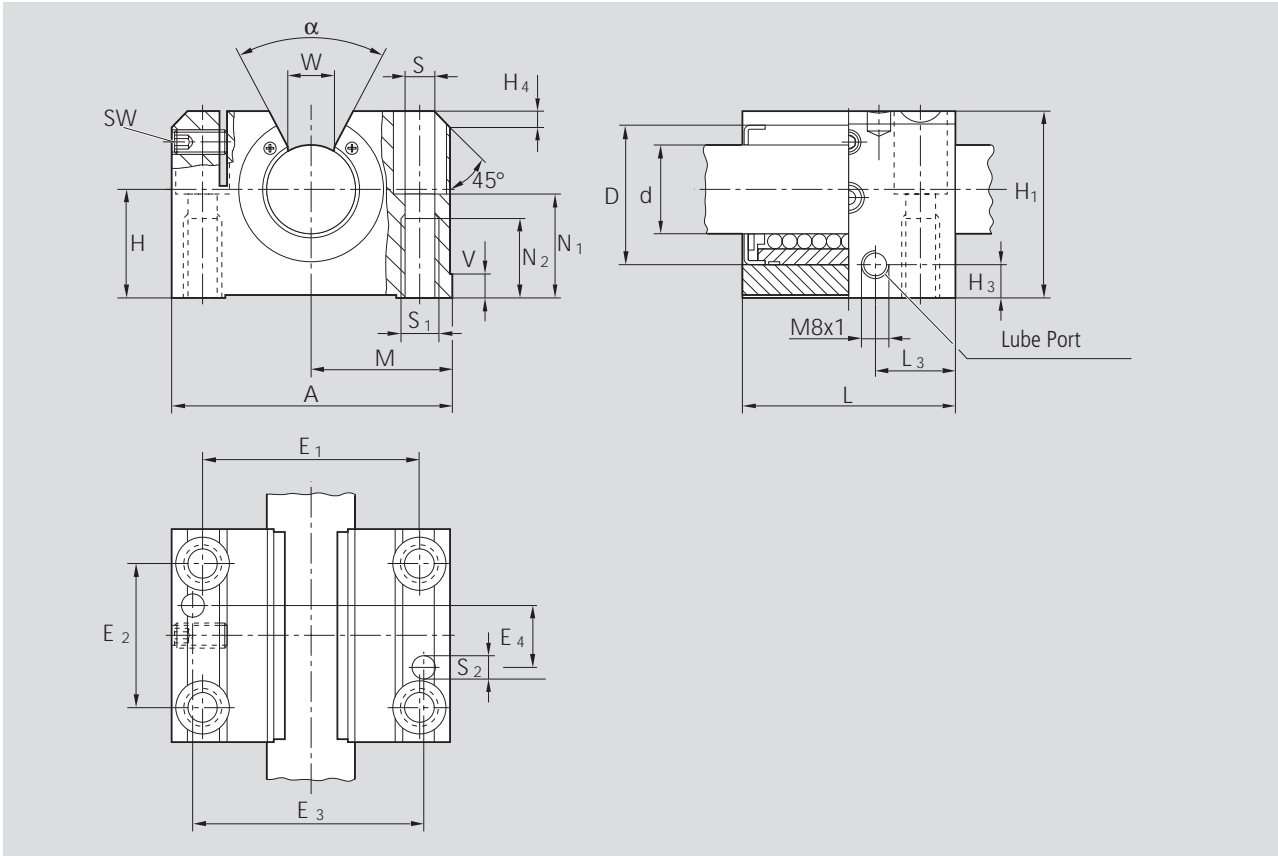

Dimensions (mm)																					
Ø d	D	H ¹⁾ +0.008 -0.016	H ₁	M ¹⁾ ±0.01	A	L	E ₁	E ₂	E ₃	E ₄	S	S ₁	S ₂	N ₁	N ₂	H ₃	L ₃	V	SW	W	H ₄
20	32	25	42	30	60	46	45±0.15	32±0.15	50	15	6.6	M8	5	24	18	10	16	5	2.5	9.5	3.5
25	40	30	51	39	78	59	60±0.15	40±0.15	64	17	8.4	M10	6	29	22	10	21	6.5	3	12	4
30	47	35	60	43.5	87	69	68±0.15	45±0.15	72	20	8.4	M10	6	34	22	11.5	26	8	3	12.8	6
40	62	45	77	54	108	81	86±0.15	58±0.15	90	25	10.5	M12	8	44	26	14	30	10	4	16.8	6
50	75	50	88	66	132	101	108±0.20	50±0.20	108	85	13.5	M16	10	49	34	12.5	39	12	5	22.1	6
60	90	60	105	82	164	126	132±0.20	65±0.20	132	108	17.5	M20	12	59	42	15	50	13	6	27	5

Ø d (mm)	Angle (°) α	Radial clearance (µm) ²⁾		Load capacity (N) ³⁾ Super Linear Bushing								
		1703- Shaft			1704-							
		h6	h7				C		C ₀			
20	54	+31 -2	+37 0	adjusted prior to delivery to zero clearance on h5 shaft (lower limit)	2520	1880	3530	2530				
25	55	+31 -2	+37 0		4430	3360	6190	4530				
30	60	+31 -2	+37 0		6300	5230	8800	7180				
40	60	+35 -3	+42 -1		9680	7600	13500	10400				
50	52	+35 -3	+42 -1		16000	12200	22300	16800				
60	55	+39 -4	+47 -1		23500	18700	-	-				

- 1) When screwed down, relative to shaft nominal dimension d.
- 2) When screwed down.
- 3) Caution:
Reduction in load capacity due to load direction (see "Technical Data")
The figures given for load capacity are valid for the main direction of load $\varrho = 0^\circ$.

STAR – Linear Sets with Super Linear Bushings **HL** or **SH**

**Linear Sets, 1706-
with side opening, adjustable**

Structural Design

- Precision Housing (aluminum)
- Super Linear Bushing **HL** or **SH**
- Fully sealed
- Retention by means of screw
- Lubricatable

For precise values for the 4 main directions of load see "Technical Data – Load capacity factors".

Note:

The diagrams for load capacity factors correspond to a mounting position as given in the photo below and therefore differ from the information given under "Technical Data".

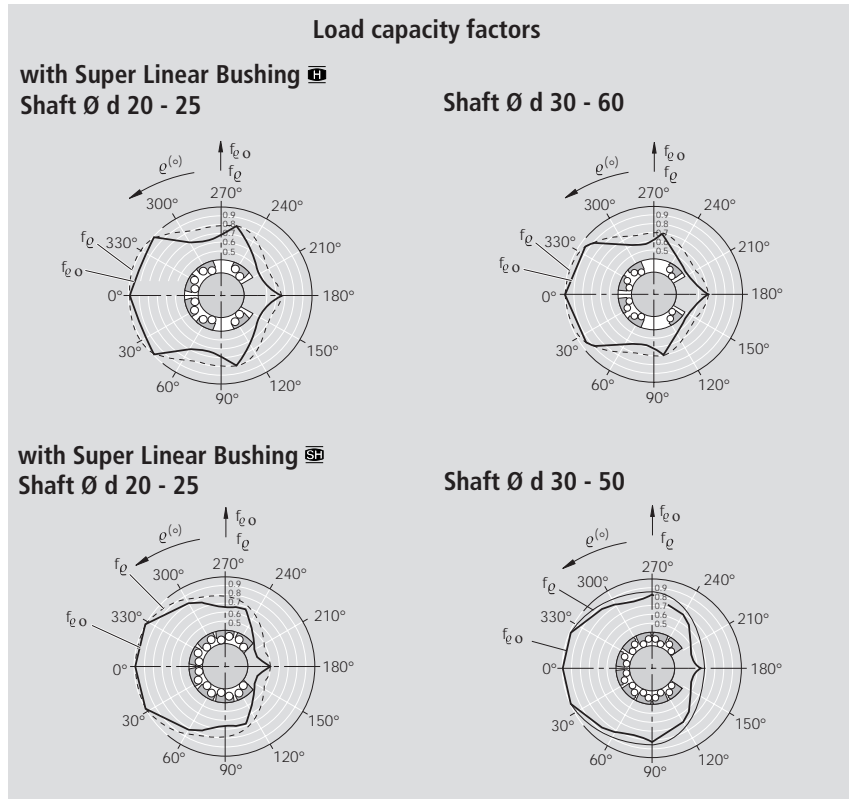

Ordering data

with side opening, adjustable



Shaft Ø d (mm)	Part numbers with Super Linear Bushing		Mass (kg) with Super Linear Bushing	
	HL	SH	HL	SH
20	1706-220-70	1706-420-70	0.35	0.37
25	1706-225-70	1706-425-70	0.70	0.73
30	1706-230-70	1706-430-70	1.03	1.10
40	1706-240-70	1706-440-70	1.80	1.95
50	1706-250-70	1706-450-70	3.00	3.25

The figures for dynamic load-carrying capacity have been calculated assuming a nominal travel of 100,000 m.
For a nominal travel of 50,000 m, the 'C' figures in the table on the opposite page must be multiplied by a factor of 1.26.

Dimensions

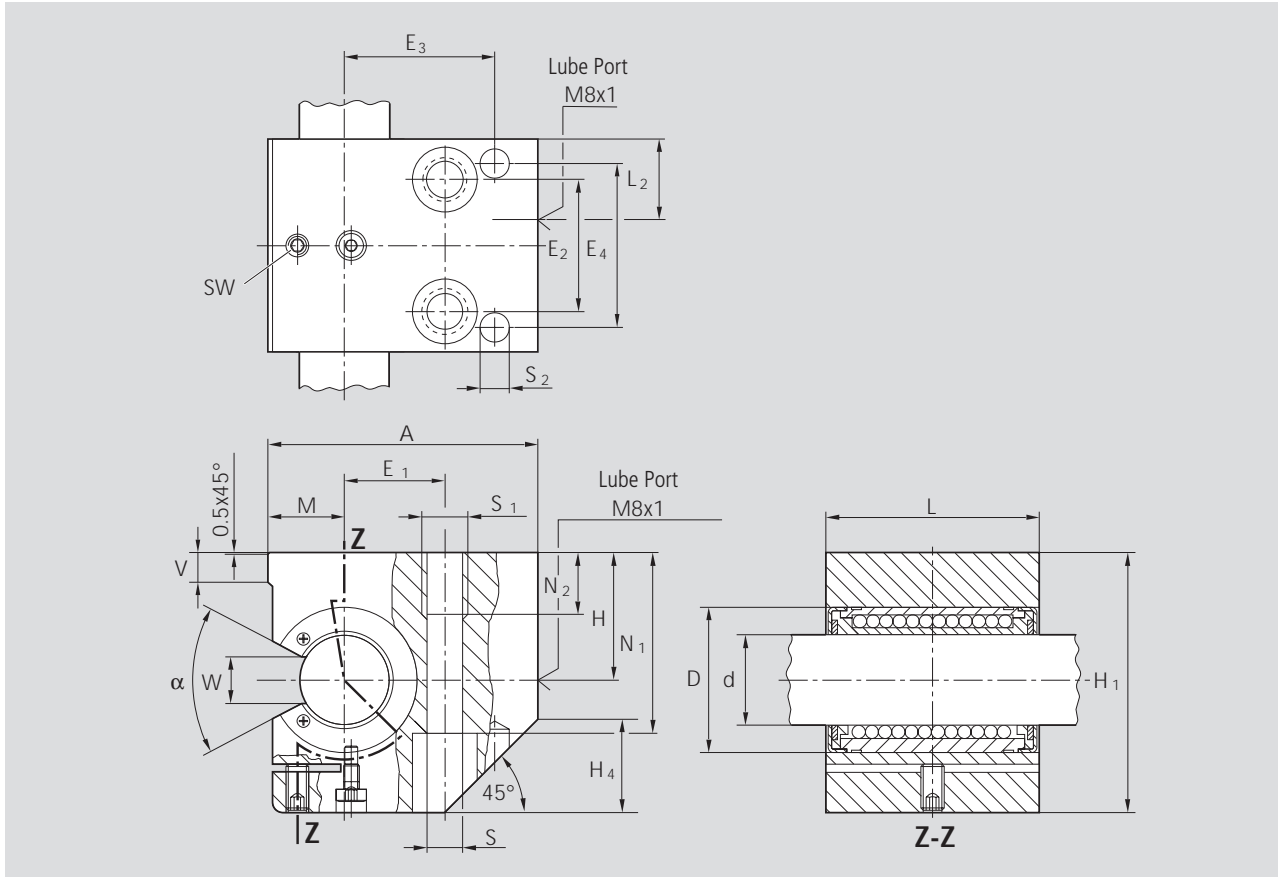

Dimensions (mm)																				
Ø d	D	H ¹⁾ +0.008 -0.016	H ₁	M ¹⁾ ±0.01	A	L	E ₁	E ₂	E ₃	E ₄	S	S ₁	S ₂	N ₁	N ₂	L ₃	V	SW	W	H ₄
20	32	30	60	17	60	47	22±0.15	30±0.15	35	35	8.4	M10	6	42	15	17.5	5	2.5	9.5	22
25	40	35	72	21	75	59	28±0.15	36±0.15	42	45	10.5	M12	8	50	18	22	6.5	3	12	26
30	47	40	82	25	86	69	34±0.15	42±0.15	52	52	13.5	M16	10	55	24	27	8	3	12.8	30
40	62	45	100	32	110	81	43±0.15	48±0.15	65	60	15.5	M20	12	67	30	31	10	4	16.8	38
50	75	50	115	38	127	101	50±0.15	62±0.15	75	75	17.5	M20	12	78	30	39	12	5	22.1	45

Ø d (mm)	Angle (°) α	Radial clearance ²⁾ (µm)	Load capacity ³⁾ (N)			
			Super Linear Bushing			
			C	C ₀	C	C ₀
20	54	adjusted prior to delivery to zero clearance on h5 shaft (lower limit)	2520	1880	3530	2530
25	55		4430	3360	6190	4530
30	60		6300	5230	8800	7180
40	60		9680	7600	13500	10400
50	52		16000	12200	22300	16800

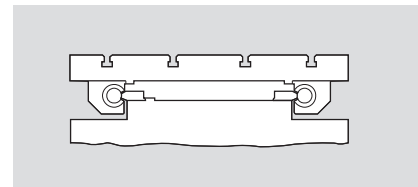

- When screwed down, relative to shaft nominal dimension d.
- When screwed down.
- Caution:
The load capacity factors of the linear bushing will change according to the mounting position.
The figures given for load capacity are valid for the main direction of load $\varrho = 0^\circ$.

STAR – Compact Linear Bushings

The range and the design of linear motion elements have had to keep pace with the emergence of new and changing demands on linear motion systems in recent years. Part of STAR's response to this challenge has been the development of the Compact Linear Bushing, the space-saving addition to its Linear Motion Program.

Due to their small overall dimensions, Compact Linear Bushings help to build especially neat structures.

Compact Linear Bushings are available in the following types:

- standard type
- type with reduced radial clearance (RT)
- corrosion-resistant type (anti-friction bearing steel to DIN 17230 / EN 10088)
- with or without seals
- Compact Linear Sets (linear bushing with housing) in various types
- **Compact Linear Bushings are also available with STAR-Resist corrosion protection (yellow chromated zinc-iron coating)**

Advantages

- Radial clearance easily adjustable on Standard Shaft (h7 or h6 tolerance)
- High load capacity thanks to ball tracks in steel load bearing plates
- High travel speeds
- Internal wiper seals
- Low radial clearance
- No additional retaining elements required
- Available as corrosion-resistant type to DIN 17230 / EN 10088
- Low-cost solution to most problems



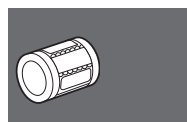
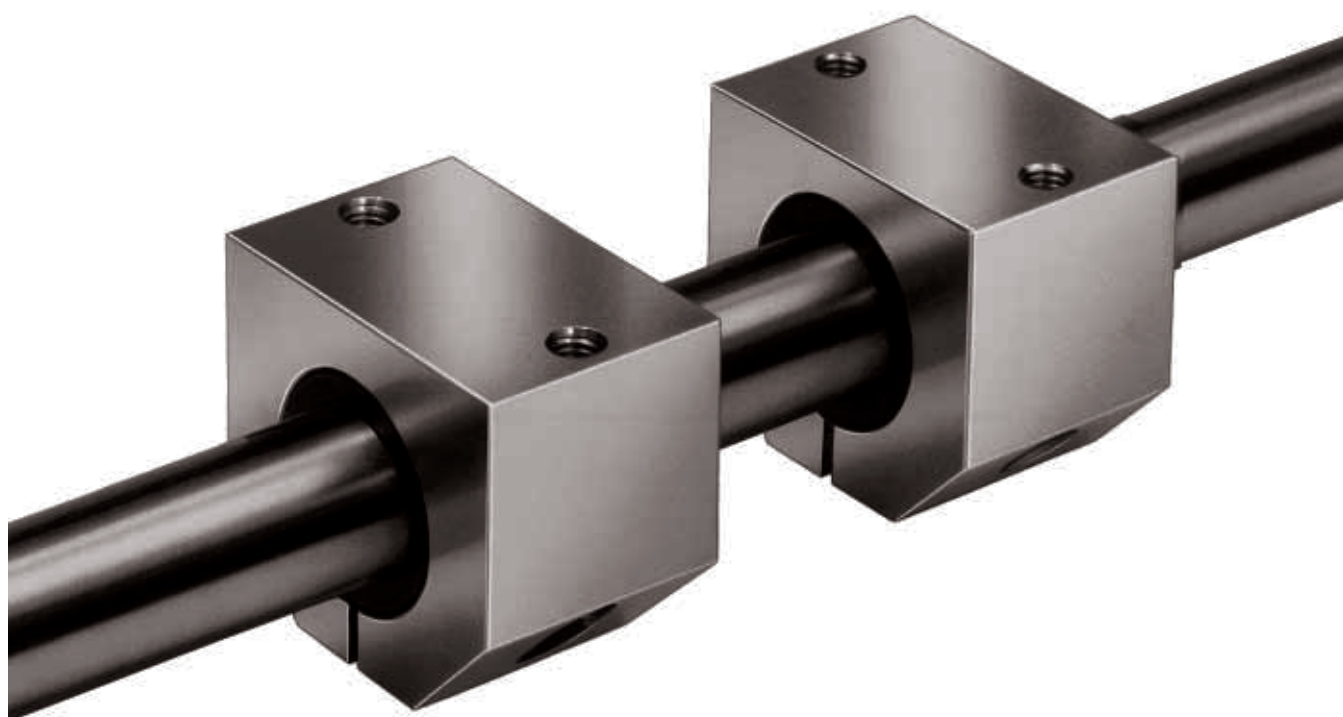

STAR – Compact Linear Bushings

Technical Data, Mounting Instructions

Please observe the general technical principles and mounting instructions at the beginning of this catalog as well as the additional technical data given below.

Sealing

The sealed standard types are fitted with integral wiper-type seals.
Separate end seals can also be ordered (no special retaining elements necessary).

Friction

The friction μ of unsealed Compact Linear Bushings using oil as a lubricant lies between 0.001 - 0.004.

The friction is lowest under high load. It may, however, be greater than the stated value when only a slight load is applied.

For Compact Linear Bushings fitted at both ends with internal wiper seals and not subject to radial loading, the frictional drag (see table below) depends on the speed and the type of lubrication.

Shaft $\varnothing d$ (mm)	Breakaway force ¹⁾ (N approx.)	Frictional drag ¹⁾ (N approx.)
12	2	1
16	2.5	1.3
20	3	1.5
25	4.5	2
30	6	2.5
40	8	3
50	10	4

¹⁾ For separate wiper seals, the values must be multiplied by a factor of 1.5.

Velocity

$$v_{\max} = 5 \text{ m/s}$$

Acceleration

$$a_{\max} = 150 \text{ m/s}^2$$

Operating temperature

up to 100 °C

Direction of load and its influence on the load capacity

The load capacities given are valid for installation in "min" position and should be taken as the basis for calculation.

In applications where the direction of load is exactly known and where the Compact Linear Bushings can be mounted in the "max" position, the load capacity rating must be multiplied by the factors f_{max} (dynamic load capacity C) or f_{0max} (static load capacity C_0).

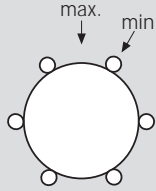
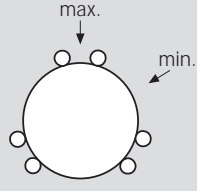
Shaft Ø d (mm)	Load capacity factors		 Shaft Ø d 12 and 16	 Shaft Ø d 20 to 50
	f_{max}	f_{0max}		
12, 16	1.19	1.46		
20, 25, 30, 40, 50	1.26	1.48		

Reduced load capacity in short-stroke applications

In short-stroke applications, the service life of the shafts is shorter than that of the Compact Linear Bushings.

For this reason, the load capacities C listed in the tables must be multiplied by the factor f_w .

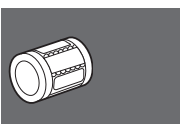
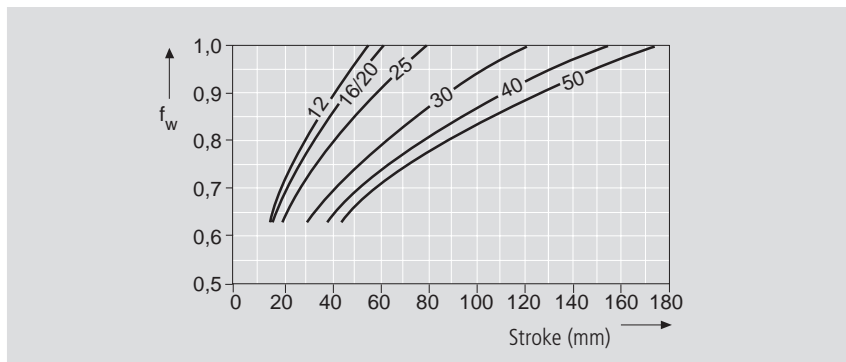

Notes for mounting

Use of an arbor is recommended for installation of Compact Linear Bushings into the housing bore (see "Mounting Instructions" in the General Technical Data at the beginning of this catalog).

If a Compact Linear Bushing is slightly skewed on entering the housing bore, it will align itself as it is inserted further. Removal of the Compact Linear Bushing and re-alignment are unnecessary.

Retention

No special retention elements are necessary, provided Compact Linear Bushings are installed in a bore according to the dimensions given in the tables.

STAR – Compact Linear Bushing

Compact Linear Bushing, 0658- also in corrosion-resistant type

Structural design

- Ball retainer made of POM
- Without seals
- Internal/separate seals
- Balls made of anti-friction bearing steel
- Hardened steel segmental load bearing plates
- Metal holding rings

Ordering data



Compact RT type

With reduced radial clearance for applications requiring low-clearance operation with H7 bores.

Corrosion-resistant type

(anti-friction bearing steel to DIN 17230 / EN 10088)

Corrosion-resistant Compact Linear Bushings have the same overall dimensions as the standard type and are thus fully interchangeable with them.

- Balls made of corrosion-resistant antifriction bearing steel
- Corrosion-resistant steel segmental load bearing plates
- Corrosion-resistant steel holding rings

Shaft Ø d (mm)	Part numbers without seals			Mass (kg)
	Compact	Compact RT	Compact corrosion-resistant	
12	0658-012-00	0658-051-00	0658-012-30	0.016
16	0658-016-00	0658-052-00	0658-016-30	0.025
20	0658-020-00	0658-053-00	0658-020-30	0.028
25	0658-025-00	0658-054-00	0658-025-30	0.058
30	0658-030-00	0658-055-00	0658-030-30	0.080
40	0658-040-00	0658-056-00	0658-040-30	0.140
50	0658-050-00	0658-057-00	0658-050-30	0.170

Shaft Ø d (mm)	Part numbers with two seals			Mass (kg)
	Compact	Compact RT	Compact corrosion-resistant	
12	0658-212-40	0658-251-40	0658-212-30	0.016
16	0658-216-40	0658-252-40	0658-216-30	0.025
20	0658-220-40	0658-253-40	0658-220-30	0.028
25	0658-225-40	0658-254-40	0658-225-30	0.058
30	0658-230-40	0658-255-40	0658-230-30	0.080
40	0658-240-40	0658-256-40	0658-240-30	0.140
50	0658-250-40	0658-257-40	0658-250-30	0.170

With one seal: 0658-1..-40 or 0658-1..-30.

separate seals



Shaft Ø d (mm)	Part numbers seal with metal casing
12	1331-812-10
16	1331-816-10
20	1331-820-10
25	1331-825-10
30	1331-830-10
40	1331-840-10
50	1331-850-10

The figures for dynamic load-carrying capacity have been calculated assuming a nominal travel of 100,000 m. For a nominal travel of 50,000 m, the 'C' figures in the table must be multiplied by a factor of 1.26.

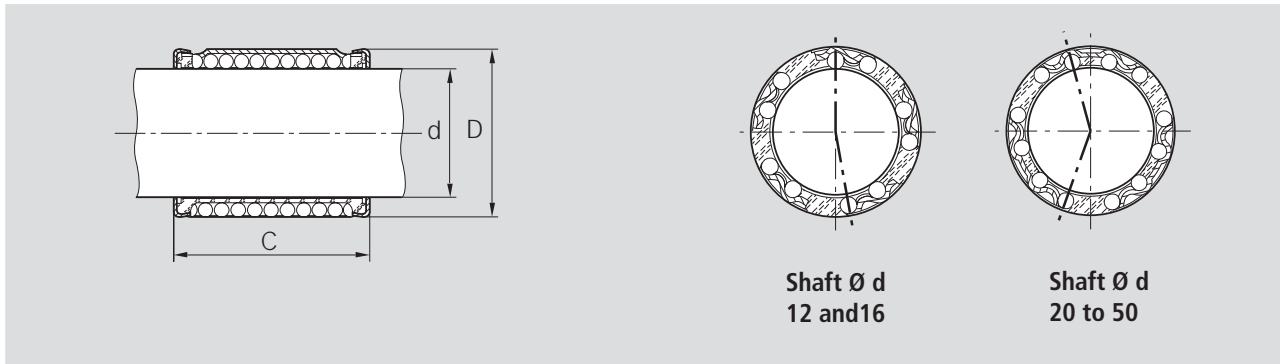

Dimensions (mm)			No. of ball circuits	Radial clearance (μm) shaft/bore				Load capacities ³⁾ (N)			
$\varnothing d$	D ¹⁾	C ± 0.2		Compact ²⁾ , Compact corrosion-resistant ²⁾			Compact RT (reduced radial clearance) h7/H7	standard		corrosion-resistant	
			h7/H7	h7/JS7	h6/JS6	dyn.		stat.	dyn.	stat.	
12	19	28	5	+37 +2	+26 -8	+19 -8	+13 -22	730	420	510	340
16	24	30	5	+37 +2	+26 -8	+19 -8	+13 -22	950	500	660	400
20	28	30	6	+38 +2	+28 -9	+20 -9	+14 -22	1120	610	780	480
25	35	40	6	+42 +2	+29 -10	+21 -10	+18 -22	2330	1310	1630	1050
30	40	50	6	+42 +2	+29 -10	+21 -10	+18 -22	3060	1880	2140	1510
40	52	60	6	+48 +2	+33 -13	+23 -12	+24 -22	5040	3140	3520	2510
50	62	70	6	+48 +2	+33 -13	+23 -12	+24 -22	5680	3610	3970	2890

- 1) The outer diameter of the metal holding ring is slightly oversized. No special retention elements are necessary (housing bore length $\geq C$).
- 2) Tolerance K7 or K6 permissible in light-metal-alloy housings (slight preload possible).
- 3) The load capacities stated are minimum values as the positions and direction of load cannot always be precisely defined.

Seal with metal casing

$\varnothing d$	Dimensions (mm)	
	D ⁴⁾	b
12	19	3
16	24	3
20	28	4
25	35	4
30	40	4
40	52	5
50	62	5

4) The outer diameter D has been manufactured with an oversize of approx. 0.1 mm. No additional retention required.

STAR – Compact Linear Sets

Compact Linear Sets, 1027-
closed , standard or corrosion-
resistant type

Compact Linear Sets, 1028-
adjustable, standard type

Structural Design

- Precision Housing, lightweight series (aluminum)
- Compact Linear Bushing
- Two internal seals

Ordering data



Shaft Ø d (mm)	Part numbers		Mass (kg)
	Compact	Compact corrosion-resistant ¹⁾	
12	1027-212-40	1027-212-30	0.08
16	1027-216-40	1027-216-30	0.11
20	1027-220-40	1027-220-30	0.15
25	1027-225-40	1027-225-30	0.27
30	1027-230-40	1027-230-30	0.40
40	1027-240-40	1027-240-30	0.75
50	1027-250-40	1027-250-30	1.20

¹⁾ Linear Bushing, corrosion-resistant type (anti-friction bearing steel to DIN 17230 / EN 10088).



Shaft Ø d (mm)	Part numbers		Mass (kg)
	Compact		
12	1028-212-40		0.08
16	1028-216-40		0.11
20	1028-220-40		0.15
25	1028-225-40		0.27
30	1028-230-40		0.40
40	1028-240-40		0.75
50	1028-250-40		1.20

Linear Sets 1028-2-... with adjustable radial clearance are adjusted to zero clearance (when screwed down) on a shaft of diameter accurate to a tolerance of h5 (lower limit) prior to delivery.

The figures for dynamic load-carrying capacity have been calculated assuming a nominal travel of 100,000 m.

For a nominal travel of 50,000 m, the 'C' figures in the table must be multiplied by a factor of 1.26.

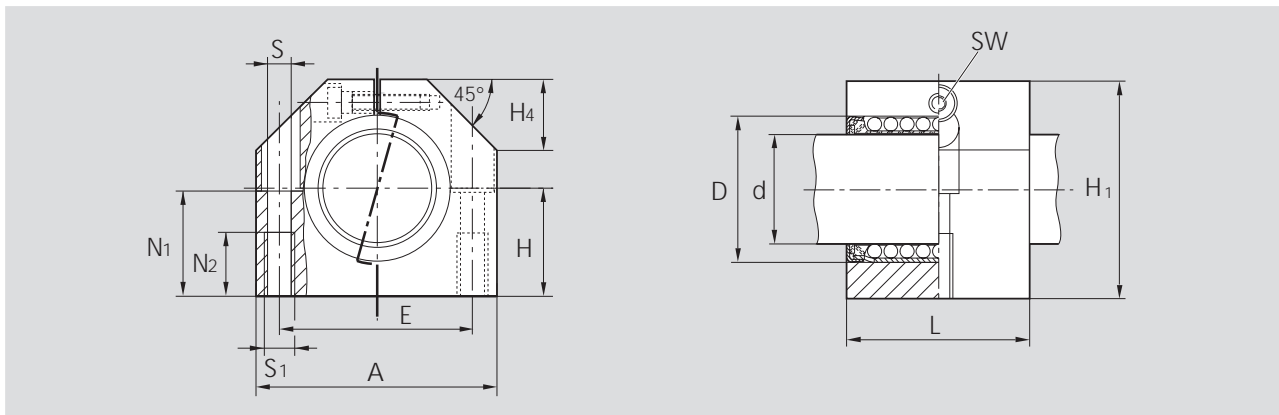

Dimensions (mm)												
Ø d	D	H	H ₁	A	L	E	S ¹⁾	S ₁	N ₁	N ₂	H ₄	SW
12	19	17	33	40	28	29	4.3	M5	16	11	11	2.5
16	24	19	38	45	30	34	4.3	M5	18	11	13	2.5
20	28	23	45	53	30	40	5.3	M6	22	13	15	3
25	35	27	54	62	40	48	6.6	M8	26	18	17	4
30	40	30	60	67	50	53	6.6	M8	29	18	19	4
40	52	39	76	87	60	69	8.4	M10	38	22	24	5
50	62	47	92	103	70	82	10.5	M12	46	26	30	6



Ø d (mm)	Radial clearance (µm)		Tolerance (µm)	Load capacities ³⁾ (N)				
	1027-...			Compact		Compact corrosion-resistant		
	shaft h6	shaft h7		dyn. C	stat. C ₀	dyn. C	stat. C ₀	
12	+32 0	+37 +2	adjusted prior to delivery to zero clearance on h5 shaft (lower limit)	±12	730	420	510	340
16	+32 0	+37 +2		±12	950	500	660	400
20	+33 -1	+38 +2		+13 -12	1120	610	780	480
25	+36 0	+42 +2		+13 -12	2330	1310	1630	1050
30	+36 0	+42 +2		+13 -12	3060	1880	2140	1510
40	+42 -1	+48 +2		+14 -12	5040	3140	3520	2510
50	+42 -1	+48 +2		+14 -12	5680	3610	3970	2890

- 1) Mounting screws to ISO 4762-8.8.
- 2) Relative to shaft nominal dimension d.
- 3) The load capacities stated are minimum values as the position and direction of load cannot always be precisely defined.

STAR – Segmental Linear Bushings

The Segmental Linear Bushing is the least expensive of the Linear Bushing range. This time-tested machine element is also available in a corrosion-resistant version. In many fields, such as the food, film and photo industries, the corrosion-resistant type offers appreciable advantages over conventional guide elements.

Each load bearing plate has one ball track in which the balls roll.

This ensures an optimum area of contact between the ball and the bearing plate, permitting better load distribution and thus higher load capacities than are attainable with conventional types of linear bearings.

STAR Segmental Linear Bushings – the low-cost solution

Segmental Linear Bushings are available in the following versions:

- standard type
- corrosion-resistant type (antifriction bearing steel to DIN 17230 / EN 10 088)
- without seals
- with separate seals

Advantages

- Low noise
- Low weight
- Anti-corrosion steel shaft available to DIN 17230 / EN 10088
- Low price



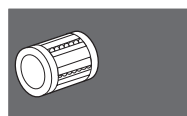

STAR – Segmental Linear Bushings

Technical Data

Please observe the general technical principles and mounting instructions at the beginning of this catalog as well as the additional technical data given below.

Friction

The friction μ of unsealed Segmental Linear Bushings using oil as a lubricant lies between 0.001 and 0.004.

The friction is lowest under high load. It may, however, be greater than the stated value when only a slight load is applied. The frictional drag (see table) in the linear bushings sealed at both ends and not subject to radial loading depends on the speed and the type of lubrication.

Shaft $\varnothing d$ (mm)	Breakaway force (N approx.)	Frictional drag (N approx.)
12	3	1.5
16	4.5	2
20	5	2.5
25	7	3
30	9	4
40	12	5

Velocity

$$v_{\max} = 3 \text{ m/s}$$

Acceleration

$$a_{\max} = 150 \text{ m/s}^2$$

Operating temperature

up to 100 °C

Direction of load and its influence on the load capacity

The stated load capacities are valid for installation in "min" position and should be taken as the basis for calculation.

In applications where the direction of load is exactly known and where the Segmental Linear Bushings can be mounted in the "max" position, the load capacity rating must be multiplied by the factors f_{\max} (dynamic load capacity C) or $f_{0 \max}$ (static load capacity C_0).

Shaft $\varnothing d$ (mm)	Load capacity factors		
	f_{\max}	$f_{0 \max}$	
12, 16	1.19	1.46	
20, 25, 30, 40	1.06	1.28	

Mounting, Retention

Reduced load capacity in short-stroke applications

In short-stroke applications, the service life of the shafts is shorter than that of the Segmental Linear Bushings.

For this reason, the load capacities C listed in the tables must be multiplied by the factor f_w .

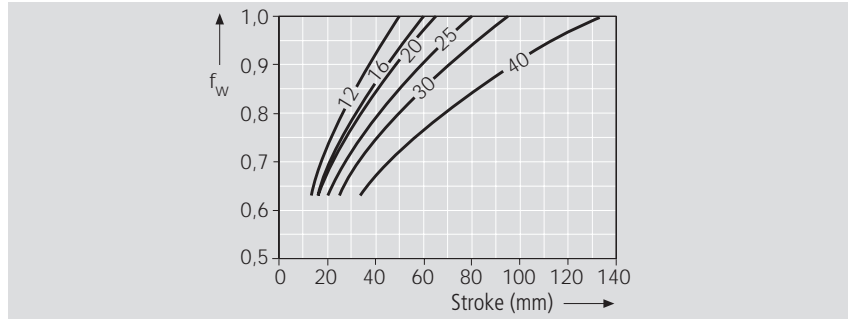

Operation under difficult conditions

In permanently humid or wet environments due for instance to water-based coolants/ lubricants, we recommend the use of the corrosion-resistant type to DIN 17230 / EN 10088.

Notes for mounting

Use of an arbor is recommended for installation of Segmental Linear Bushings into the housing bore (see "Mounting Instructions" in the General Technical Data at the beginning of this catalog).

When Segmental Linear Bushings are mounted in an adjustable housing we recommend installing the linear bushing with one of its load bearing plates covering the slot in the housing; this will prevent dirt from entering the linear bushing.

Retention

Retention by means of a seal with metal case

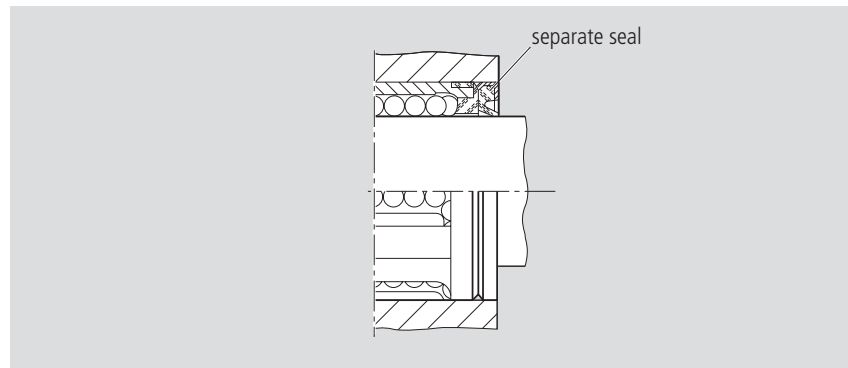

Retention by means of metal case

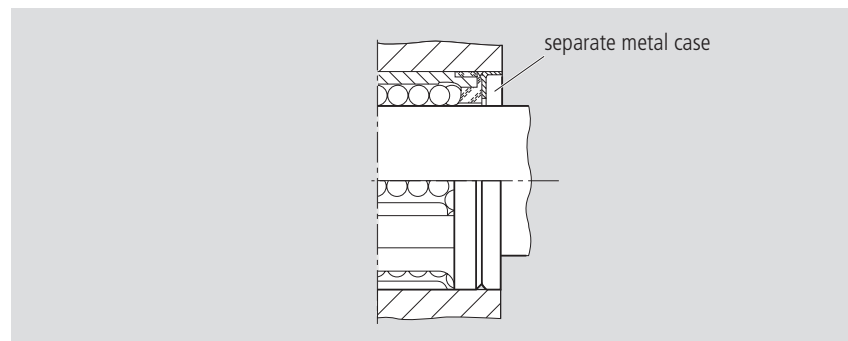

STAR – Segmental Linear Bushings

Segmental Linear Bushings, 0668- standard or corrosion-resistant type

Structural Design

- Balls made of anti-friction bearing steel
- Hardened steel segmental load bearing plates
- Ball retainer made of polyamide

Corrosion-resistant type

(anti-friction bearing steel to DIN 17230 / EN 10088)
The time-tested Segmental Linear Bushing is available in a corrosion-resistant version for use in hostile environment. In many fields, such as the food, film and photo industries, the corrosion-resistant type offers appreciable advantages over conventional linear guide elements.

- Balls of corrosion-resistant antifriction bearing steel
- Corrosion-resistant steel segmental load bearing plates
- Ball retainer made of polyamide 11

Ordering data



Shaft Ø d (mm)	Part numbers		Mass (kg)
	standard	corrosion-resistant	
12	0668-012-00	0668-012-30	0.013
16	0668-016-00	0668-016-30	0.020
20	0668-020-00	0668-020-30	0.031
25	0668-025-00	0668-025-30	0.057
30	0668-030-00	0668-030-30	0.096
40	0668-040-00	0668-040-30	0.170



separate seals / metal case

Shaft Ø d (mm)	Part numbers			
	seal with metal case	metal case ¹⁾	seal with corrosion-resistant metal case	corrosion-resistant metal case ¹⁾
12	1331-512-00	0901-043-00	1331-512-30	0901-043-30
16	1331-516-00	0901-044-00	1331-516-30	0901-044-30
20	1331-520-00	0901-045-00	1331-520-30	0901-045-30
25	1331-525-00	0901-046-00	1331-525-30	0901-046-30
30	1331-530-00	0901-047-00	1331-530-30	0901-047-30
40	1331-540-00	0901-048-00	1331-540-30	0901-048-30

¹⁾ for axial retention

The figures for dynamic load-carrying capacity have been calculated assuming a nominal travel of 100,000 m. For a nominal travel of 50,000 m, the 'C' figures in the table must be multiplied by a factor of 1.26.

Dimensions

Segmental Linear Bushings (standard and corrosion-resistant types)

Corrosion-resistant Segmental Linear Bushings have the same overall dimensions as standard Segmental Linear Bushings and are thus fully interchangeable with them.

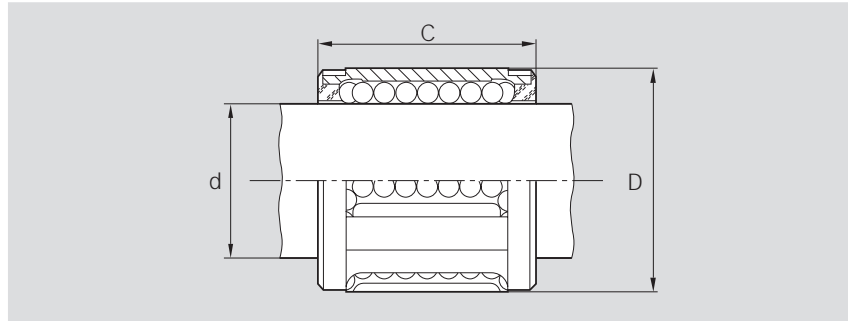

Dimensions (mm)			No. of ball circuits	Radial clearance (µm) shaft/bore			Load capacities ¹⁾ (N)			
Ø d	D	C js 14		h7/H7	h7/JS7	h6/JS6	standard dyn. C	standard stat. C ₀	corrosion-resistant dyn. C	corrosion-resistant stat. C ₀
12	20	24	5	+37 +2	+26 -8	+19 -8	480	420	240	330
16	25	28	5	+37 +2	+26 -8	+19 -8	720	620	360	490
20	30	30	6	+38 +2	+28 -9	+20 -9	1020	870	510	690
25	37	37	6	+42 +2	+29 -10	+21 -10	1630	1360	820	1090
30	44	44	6	+42 +2	+29 -10	+21 -10	2390	1960	1200	1570
40	56	56	6	+48 +2	+33 -13	+23 -12	3870	3270	1940	2610



¹⁾ The load capacities stated are minimum values as the position and direction of load cannot always be precisely defined.

Seal with metal case/ with corrosion-resistant steel metal case

Ø d	Dimensions (mm)	
	D ²⁾	b +0.3
12	20	3
16	25	3
20	30	4
25	37	4
30	44	5
40	56	5

²⁾ Outer diameter D is about 0.1 mm oversize. No special retention elements are necessary.

STAR – Linear Sets with Segmental Linear Bushings

Linear Sets, 1060- adjustable, standard or corrosion-resistant type

Structural Design

- Pillow Block Housing (reinforced polyamide)
- Segmental Linear Bushing
- Two seals with snap covers
- Bolt, washer, nut
- Adjustable radial clearance

Ordering data



Shaft Ø d (mm)	Part numbers		Mass (kg)
	standard	corrosion-resistant ¹⁾	
12	1060-212-00	1060-212-20	0.041
16	1060-216-00	1060-216-20	0.063
20	1060-220-00	1060-220-20	0.077
25	1060-225-00	1060-225-20	0.158
30	1060-230-00	1060-230-20	0.277
40	1060-240-00	1060-240-20	0.470

¹⁾ Linear Bushing, corrosion-resistant type (anti-friction bearing steel to DIN 17230 / EN 10088).

The figures for dynamic load-carrying capacity have been calculated assuming a nominal travel of 100,000 m. For a nominal travel of 50,000 m, the 'C' figures in the table must be multiplied by a factor of 1.26.

Dimensions

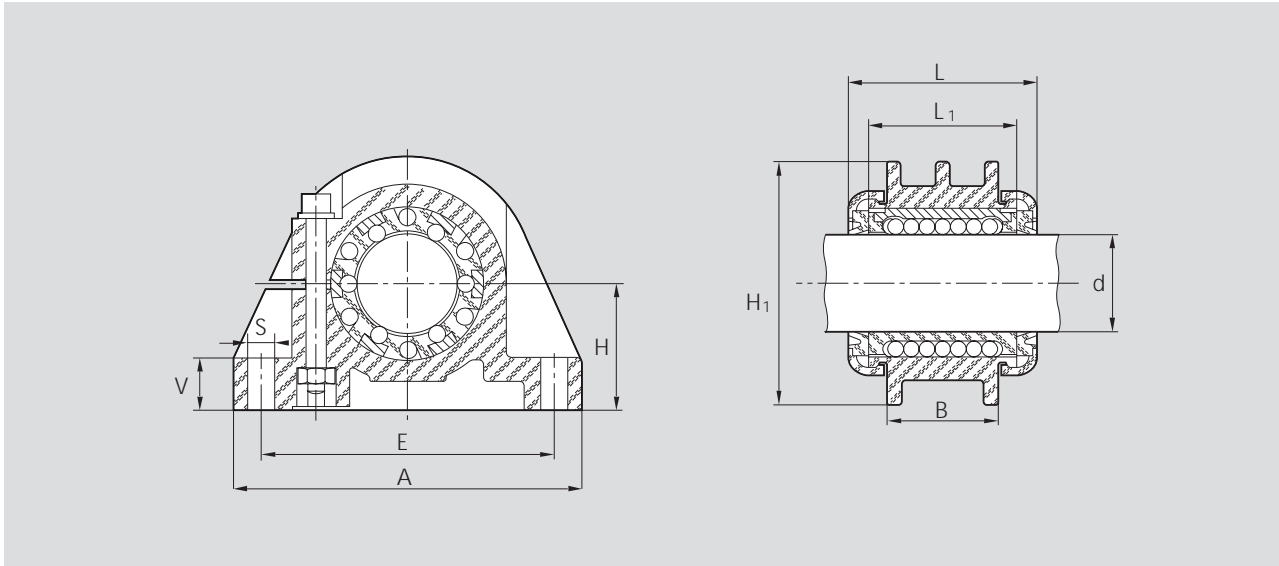

		Dimensions (mm)								Radial clearance (μm)	Load capacities ²⁾ (N)			
$\varnothing d$	$H^1)$ ± 0.05	H_1	L	L_1	A	B	E	S	V		standard dyn. C	standard stat. C_0	corrosion-resistant dyn. C	corrosion-resistant stat. C_0
12	18	35	31	24	55	20	43 ± 0.1	4.4	8	adjusted prior to delivery to zero clearance on h5 shaft (lower limit)	480	420	240	330
16	22	42	35	28	66	22	53 ± 0.15	5.5	9.5		720	620	360	490
20	25	50	38	30	69	23	58 ± 0.15	5.5	10.5		1020	870	510	690
25	30	60	46	37	87	30	72 ± 0.2	6.6	11.5		1630	1360	820	1090
30	35	70	55	44	97	36	80 ± 0.2	6.6	13		2390	1960	1200	1570
40	45	90	67	56	124	48	103 ± 0.2	8.6	17		3870	3270	1940	2610

¹⁾ Relative to shaft nominal dimension d.

²⁾ The load capacities stated are minimum values as the position and direction of load cannot always be precisely defined.



STAR – Radial Linear Bushings

Machine tools, many special-purpose machines, transfer and automation equipment and similar applications frequently demand linear motion assemblies that work on the antifriction rolling bearing principle, and have high rigidity and load-carrying capacity.

Radial Linear Bushings meet all these requirements.

Advantages over conventional machine guideways

Other linear bearings

- Considerably higher load capacities allow space-saving design.
- Higher rigidity
- Smoother travel

Flat-way roller bearings

- Only 4 Radial Linear Bushings are required to support a twin-shaft table and take up forces acting in all directions. A conventional single-row roller bearing arrangement would require 8 or even 12 elements, depending on the arrangement chosen, to give the table the same degree of support.
- Higher rigidity, less variation in elastic deflection during operation, and lower friction and smoother travel than many flat-way roller bearings.

Sliding ways

- Considerably lower friction and thus substantial power saving.
- Radial Linear Bushings are virtually wear-free and thus permit constant low-clearance operation.
- No stick-slip effect.

Structural design

The load-carrying balls are continuously recirculated along a number of separate ball circuits within the plastic ball retainer. As they reach the end of the load-carrying tracks they are lifted off radially outward and returned via the axial return bores back to the start of the load-carrying zone. While in the transition zone and the return bore, the balls run free from load. Each ball raceway forms a closed circuit, so that unlimited travel is possible.

The radial lift-off into the return bores makes it possible to incorporate more than twice the ball circuits contained in conventional linear bearings, as well as increasing the length of the load-carrying zones. This significantly increases the rigidity and the load capacity of the linear motion assembly.



Radial Linear Bushing

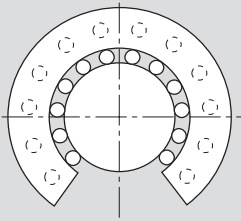

Ø 30 mm C = 8500 N

Conventional linear bearing

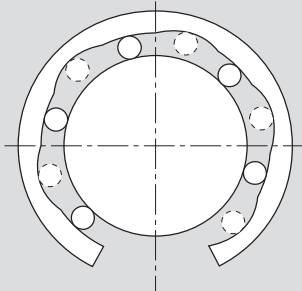

Ø 50 mm C = 8470 N

This diagram shows how the high load capacity permits a considerable reduction in dimensions.

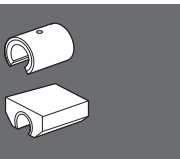

STAR – Radial Linear Bushings

Technical Data

Please observe the general technical principles and mounting instructions at the beginning of this catalog as well as the additional technical data given below.

Sealing

Radial Linear Bushings can be supplied

- fully sealed with internal wiper-type seals and axial seal strip, or
- with separate seals specially designed for use with Radial Linear Bushings.

Friction

The coefficient of friction μ of unsealed Radial Linear Bushings lies between 0.001 and 0.002. This low friction coefficient makes it possible to move heavy loads with a minimum of power consumption.

Radial Linear Bushings with separate seals or fully sealed achieve the following friction ratings.

Shaft $\varnothing d$ (mm)	Separate Seals		Fully sealed	
	Breakaway force (N approx.)	Frictional drag (N approx.)	Breakaway force (N approx.)	Frictional drag (N approx.)
30	24	8	24	12
40	32	11	32	16
50	40	14	40	20
60	48	16	48	24
80	60	20	60	30

Velocity

$$v_{\max} = 2 \text{ m/s}$$

Acceleration

$$a_{\max} = 50 \text{ m/s}^2$$

Operating temperature

up to 100 °C
with separate seals 80 °C, brief peaks up to 100 °C

Direction of load and its influence on the load capacity

The load capacity ratings C and C_0 given for Radial Linear Bushings apply when the load is acting along the line $\varrho = 0^\circ$. If the external load acts at an angle $\varrho = 90^\circ$ to 270° , allowance must be made for a reduction in load capacity by multiplying the load capacities C and C_0 by the load capacity factors f_ϱ and f_{ϱ_0} .

The reduction in the load capacity can be minimized by selective circumferential positioning of the Radial Linear Bushings.

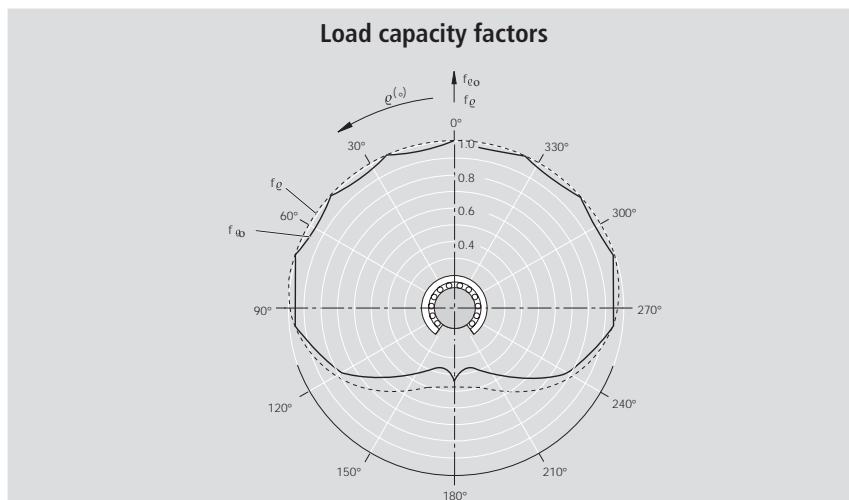

Rigidity

When used in conjunction with a continuously supported guide shaft Radial Linear Bushings constitute extremely accurate linear motion assemblies with a minimum of elastic deflection.

The chart below shows the elastic deflection of Radial Linear Bushings as a function of the load. The chart applies for installation under the following conditions:

- no preload
- zero clearance (no preload)
- for loads acting at angles of $\varrho = 0^\circ$ to 90° and 270° to 360° .

Rigidity of Radial Linear Bushings

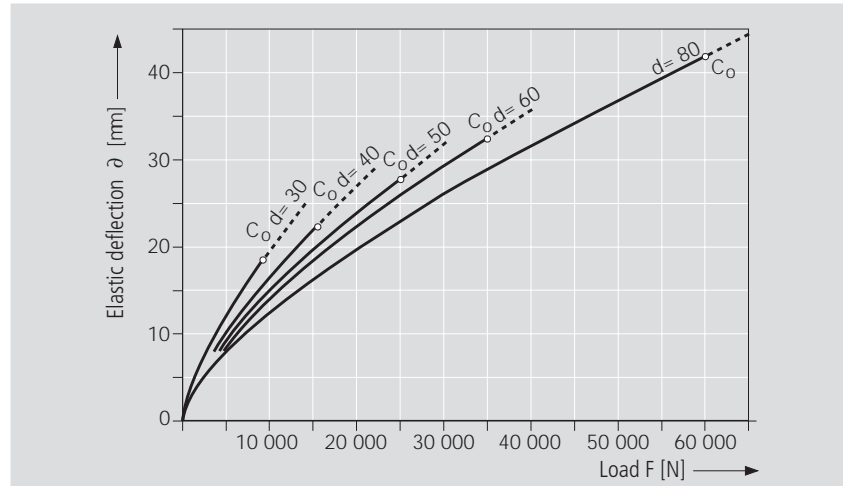

Mounting with preload reduces the elastic deflection. The additional elastic deflection of all other elements in the assembly (housing, shafts, shaft support rails) depends on the direction in which the load is acting.

Guide values for total elastic deflection: with Star elements 1075-/1076 and 1052-:

Load direction factor multiplied by the elastic deflection Δ (see chart above).

Load direction ϱ	0°	90°	180°	270°
Elastic deflection	$1 \cdot \Delta$	$1.8 \cdot \Delta$	$3.5 \cdot \Delta$	$1.8 \cdot \Delta$

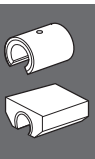

STAR – Radial Linear Bushings

Mounting, Retention

Installation, retention

For maximum rigidity, Radial Linear Bushings must be installed on continuously supported shafts. Our Linear Motion product range includes steel shaft support rails in standard lengths of 600 mm. The Radial Bushings must be inserted into the housings as described in the mounting procedure.

In applications where vibration or high acceleration rates are to be anticipated, and in particular for vertical installations, use of some additional means of retention is recommended. The following assembly sequence should always be observed: first bolt the shafts to the shaft supports, then align the housings with the Radial Linear Bushings on the shafts, and only then bolt the assembly to the table.

Recommended tolerances

The tolerances for the housing bore can be taken from the table for Radial Linear Bushings. The housing may have a slot and adjusting screw at one side for establishing the desired clearance or preload. Radial Linear Bushings are also available as part of Linear Sets complete with matching housing. For details on permissible parallelism offset, please refer to the "General Technical Data and Mounting Instructions" at the beginning of this catalog.

Lubricating instructions

Lubricate only with shaft inserted; add lubricant until excess emerges.

Procedure for mounting Radial Linear Bushings

To prevent damage to the assembly during installation, it is essential that Radial Linear Bushings be inserted into the housing with the aid of a press or bearing extractor. The following instructions and illustrations should be observed during installation. The outer sleeve of the Radial Linear Bushing and the surface of the mounting bore in the housing must be free from all oil residue before commencement of installation.

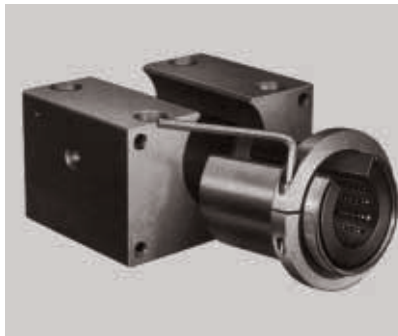

Slip a slotted mounting ring (order number 0940-0..-00) over the linear bushing as shown and reduce the outside diameter of the linear bushing by tightening the adjusting screw until it can easily be peared into the housing bore by hand. The bore of the mounting ring must be about 0.5 mm larger than the outside diameter D of the Radial Linear Bushing.



After pushing the Radial Linear Bushing into the housing, but before loosening the mounting ring, match up the opening of the Radial Linear Bushing with the opening in the housing. The mounting ring can now be loosened.



Use a press to push the pre-aligned Radial Linear Bushing firmly into the housing.

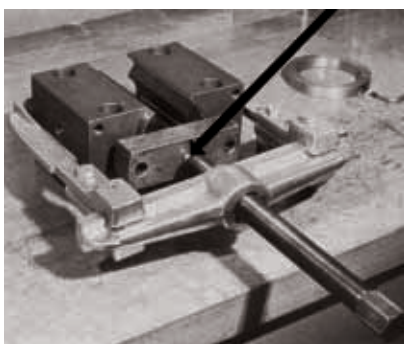

Alternatively, the pre-aligned Radial Linear Bushing can be pushed into the housing with the aid of a bearing extractor. In this case, the extractor spindle must be joined to the pressure plate via a ball bearing (see arrow). Otherwise, a separate thrust bearing must be provided in front of the extractor spindle to prevent the Radial Linear Bushing from being turned in the housing by torque exerted by the bearing extractor.

Notes

- If the openings of the Radial Linear Bushing and the housing do not match up when the linear bushing is mounted:
 - push out the Radial Linear Bushing (by means of the press or bearing extractor)
 - fit the mounting ring
 - correct the position of the linear bushing opening
 - continue the installation according to the photos and instructions above.
- The ends of the shaft must be chamfered.
- The Radial Linear Bushing must not be allowed to tilt while being pushed onto the shaft.
- Relative rotation between the shaft and the Radial Linear Bushing should be avoided.
- If external seals are used, these must be aligned with the Radial Linear Bushing and inserted by means of a press or bearing extractor.

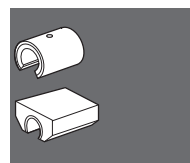

STAR – Radial Linear Bushings

**Radial Linear Bushings,
0678-
without seal or fully sealed**

Structural Design

- Hardened and ground steel sleeve
- Reinforced polyamide ball retainer
- Balls made of anti-friction bearing steel
- Two snap rings

For load capacities, see "Technical Data".

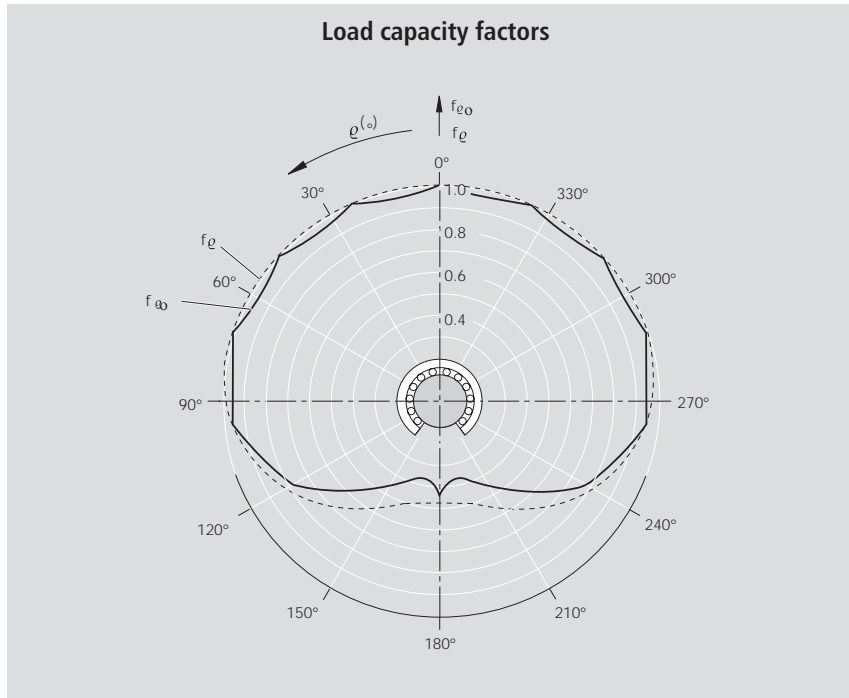

Ordering data



Shaft Ø d (mm)	Part numbers		Mass (kg)
	without seals	fully sealed	
30	0678-030-00	0678-230-45	0.7
40	0678-040-00	0678-240-45	1.4
50	0678-050-00	0678-250-45	2.5
60	0678-060-00	0678-260-45	4.9
80	0678-080-00	0678-280-45	10.4



Shaft Ø d (mm)	Part numbers		Mass (kg)
30	1331-930-00		0.050
40	1331-940-00		0.075
50	1331-950-00		0.145
60	1331-960-00		0.230
80	1331-980-00		0.400

The figures for dynamic load-carrying capacity have been calculated assuming a nominal travel of 100,000 m. For a nominal travel of 50,000 m, the 'C' figures in the table must be multiplied by a factor of 1.26.

Dimensions

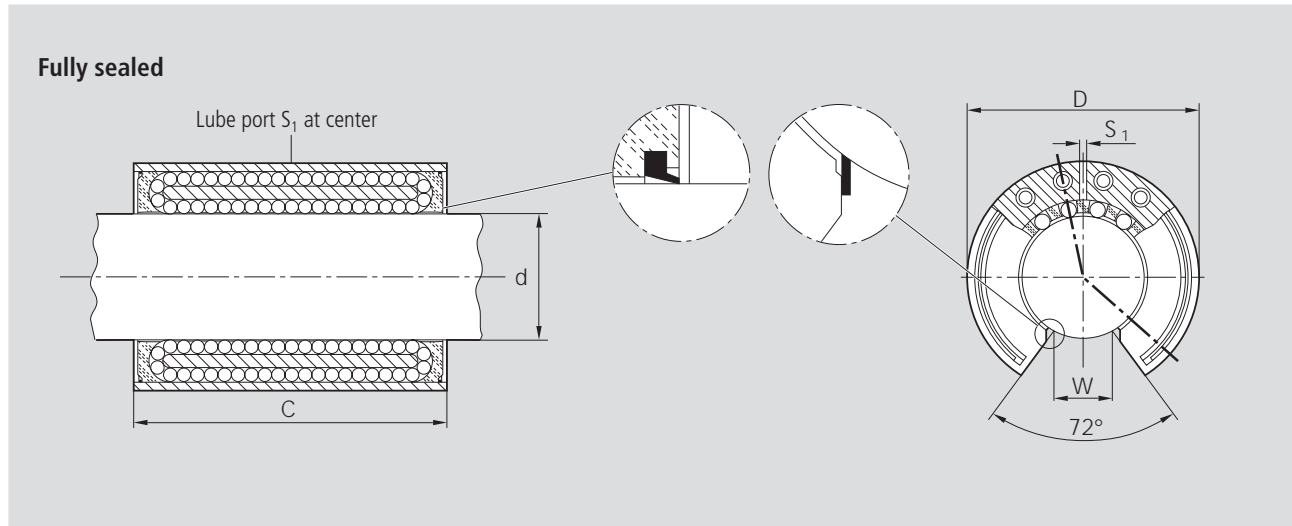

$\varnothing d$	Dimensions (mm)				No. of ball circuits	Radial clearance (μm) shaft/bore			Load capacities ³⁾	
	D	C h11	$W^{2)}$	S_1		h6/H6	h6/JS6 ¹⁾	h6/K6 ¹⁾	dyn. C (N)	stat. C_0 (N)
30	60	75	14	3	12	+21 -10	+12 -20	+6 -25	8500	9520
40	75	100	19.5	3	12	+23 -13	+13 -22	+8 -28	13900	16000
50	90	125	24.5	3	12	+25 -12	+14 -23	+7 -30	20800	24400
60	110	150	29	4	12	+26 -15	+15 -26	+8 -33	29500	34100
80	145	200	39	4	12	+29 -15	+16 -27	+8 -36	54800	61500

1) Caution: travel life may be shortened by excessive preload (see tables TB-06-052-05 and -06).

2) Lower limit relative to shaft diameter d .

3) The stated load capacities apply when the load is acting along the line $\varrho = 0^\circ$.

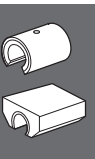

Separate seals

$\varnothing d$

b

D

73°

$\varnothing d$	Dimensions (mm)	
	$D^4)$	b
30	60	5
40	75	5
50	90	7
60	110	7
80	145	7

4) Outer diameter D is about 0.1 mm oversize. No retaining elements required except for applications subject to vibration or high acceleration.

STAR – Linear Sets with Radial Linear Bushings

Linear Sets, 1075- open type

Linear Sets, 1076- open type, adjustable

Structural Design

- Precision Housing (spheroidal graphite cast iron)
- Radial Linear Bushing
- Two seals
- Lubricatable

For load capacities, see "Technical Data" of Radial Linear Bushings.

Combined with Precision Steel Shafts and Shaft Support Rails, these Linear Sets provide linear motion assemblies of exceptional rigidity and with a high load-carrying capacity.

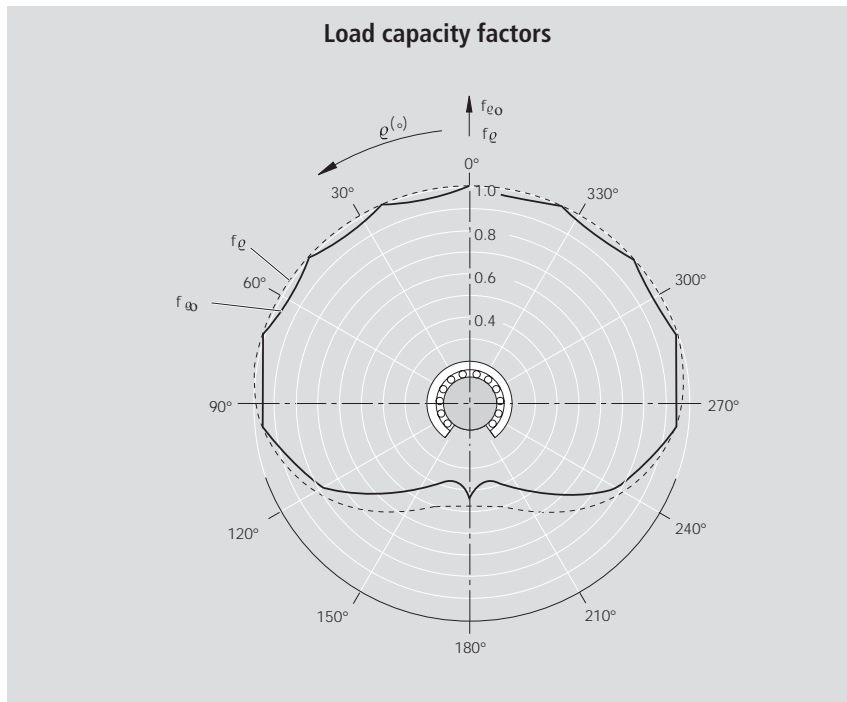

Ordering data



Shaft $\varnothing d$ (mm)	Part numbers with two seals	Mass (kg)
30	1075-230-20	6.1
40	1075-240-20	11.8
50	1075-250-20	19.7
60	1075-260-20	38.4
80	1075-280-20	76.1



Shaft $\varnothing d$ (mm)	Part numbers with two seals	Mass (kg)
30	1076-230-20	6.1
40	1076-240-20	11.8
50	1076-250-20	19.7
60	1076-260-20	38.4
80	1076-280-20	76.1

Linear Sets 1076-.. are adjusted to zero clearance (when screwed down) on a shaft of diameter accurate to a tolerance of h5 (lower limit) prior to delivery.

Dimensions

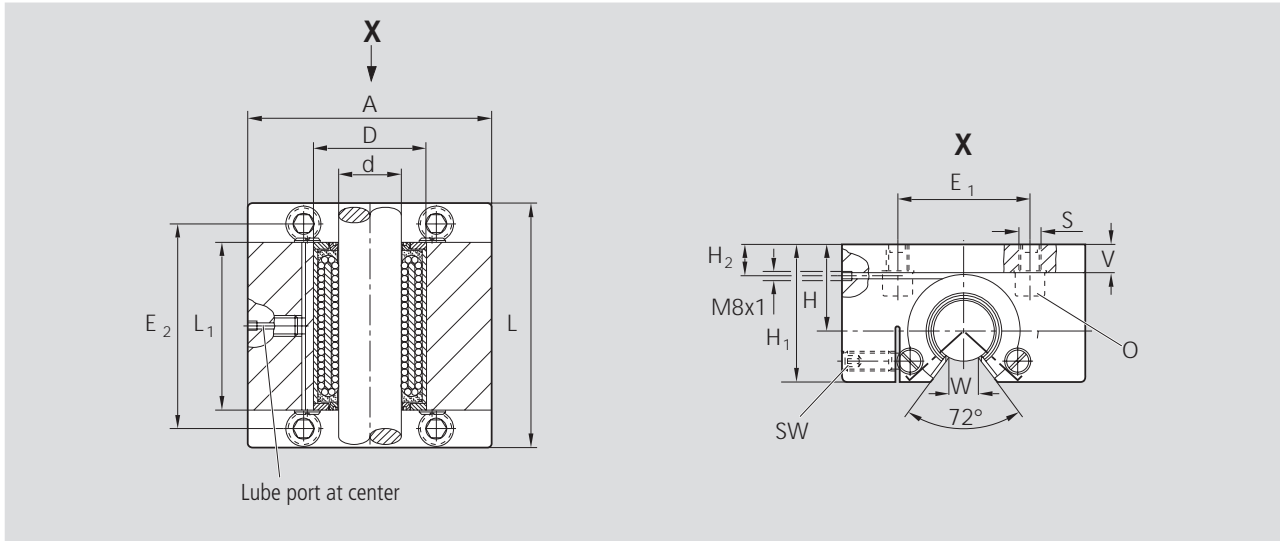

Ø d	Dimensions (mm)															Radial clearance (µm)		Tolerance (µm)	Load capacities ⁵⁾	
	D	A ³⁾	L ³⁾	L ₁ ³⁾	H	H ₁ ³⁾	H ₂	V ³⁾	E ₁ ±0.5	E ₂ ±0.5	S H13	W ⁴⁾	O ¹⁾	SW	1075-... shaft h6	1076-...	for dimension H ²⁾	dyn. C (N)	stat. C ₀ (N)	
30	60	140	130	85	48	75	18	16	75	108	11	14	M10x30	5	+21 -10	adjusted prior to delivery to zero clearance on h5 shaft (lower limit)	+15 -5	8500	9520	
40	75	170	160	110	60	94	22.5	20	90	135	14	19.5	M12x40	6	+23 -13		+17 -4	13900	16000	
50	90	200	200	139	70	110	25	23	110	170	18	24.5	M16x50	8	+25 -12		+18 -5	20800	24400	
60	110	240	240	164	85	135	30	28	130	200	22	29	M20x60	10	+26 -15		+23 -4	29500	34100	
80	145	310	310	214	110	175	37.5	35	170	260	26	39	M24x80	12	+29 -15		+22 -5	54800	61500	

- 1) Hex. socket head cap screws to ISO 4762-8.8. Applies only to fixing in tapped bores in steel or cast iron.
- 2) When screwed down, relative to shaft nominal dimension d.
- 3) Tolerance to DIN 1685-GTB 16.
- 4) Lower limit relative to shaft nominal diameter d.
- 5) The stated load capacities apply when the load is acting along the line $\varrho = 0^\circ$.

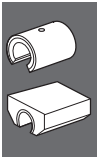

The figures for dynamic load-carrying capacity have been calculated assuming a nominal travel of 100,000 m. For a nominal travel of 50,000 m, the 'C' figures in the table must be multiplied by a factor of 1.26.

STAR – Linear Sets with Radial Linear Bushings

Linear Sets, 1077- with side opening

Linear Sets, 1078- with side opening, adjustable

Structural Design

- Precision Housing with side opening (spheroidal graphite cast iron)
- Radial Linear Bushing
- Two seals
- Lubricatable

The load carrying capacity of open linear bushings is considerably reduced when the load is applied to the "open" portion of the bushing.

This Linear Set has been developed to allow lateral installation of the Radial Linear Bushing and thus full utilization of the high load capacity rating.

Ordering data



Shaft Ø d (mm)	Part numbers with two seals	Mass (kg)
30	1077-230-20	6.5
40	1077-240-20	13
50	1077-250-20	23
60	1077-260-20	40
80	1077-280-20	87



Shaft Ø d (mm)	Part numbers with two seals	Mass (kg)
30	1078-230-20	6.5
40	1078-240-20	13
50	1078-250-20	23
60	1078-260-20	40
80	1078-280-20	87

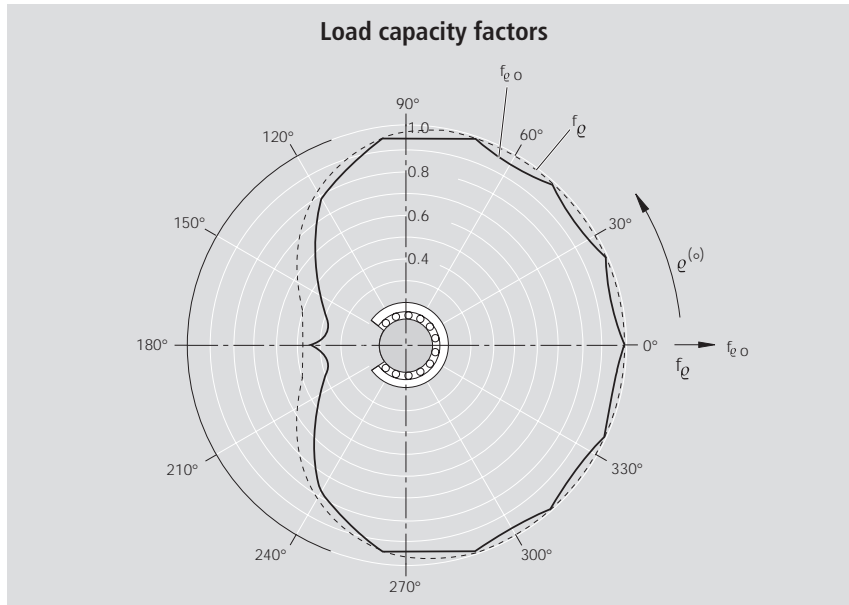

Note:

The diagram above corresponds to a mounting position as given in the photo below and therefore differs from the illustration given under "Technical Data".

Linear Sets 1078-.. are adjusted to zero clearance (when screwed down) on a shaft of diameter accurate to a tolerance of h5 (lower limit) prior to delivery.

Dimensions

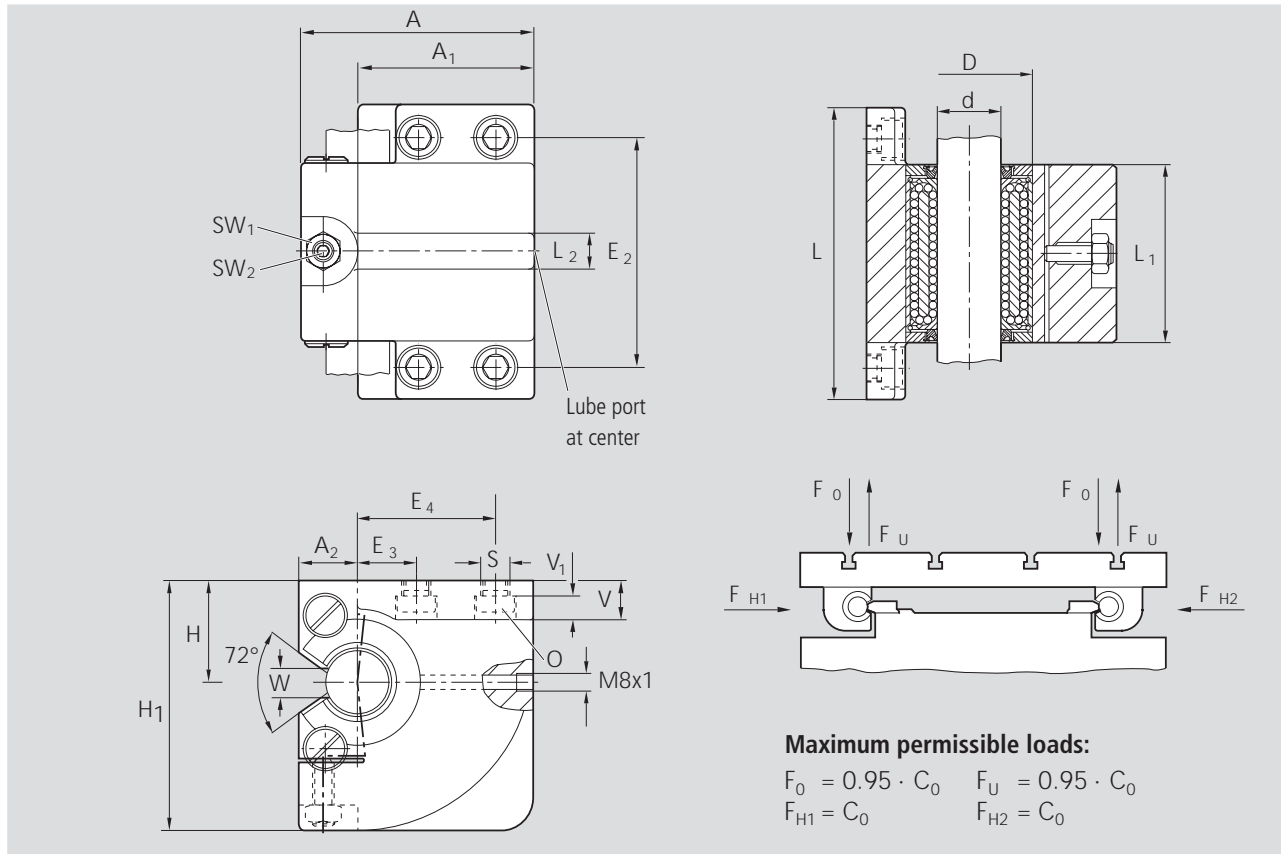

Maximum permissible loads:

$$F_0 = 0.95 \cdot C_0 \quad F_U = 0.95 \cdot C_0$$

$$F_{H1} = C_0 \quad F_{H2} = C_0$$

Dimensions (mm)																			
Ø d	D	A ¹⁾	A ₁ ¹⁾	A ₂ ¹⁾	L ¹⁾	L ₁ ¹⁾	L ₂ ¹⁾	H	H ₁ ¹⁾	V ¹⁾	V ₁	E ₂	E ₃	E ₄	S	W	SW ₁	SW ₂	O ²⁾
												±0.5	±0.5	±0.5					
30	60	110	83	27	140	85	18	48	118	18	11	110	28	65	13.5	14	17	5	M12x30
40	75	135	100	35	180	110	25	60	145	25	15	142	40	76	17.5	19.5	19	6	M16x40
50	90	165	125	40	230	139	30	70	170	30	17.5	180	50	95	22	24.5	24	8	M20x50
60	110	200	150	50	275	164	35	85	205	35	20.5	215	60	115	26	29	30	10	M24x60
80	145	265	200	65	345	214	45	110	265	45	25.5	275	75	155	33	39	36	12	M30x80

Ø d (mm)	Radial clearance (µm)		Tolerance (µm) for dimension H ³⁾	Load capacities ⁴⁾	
	1077-... shaft h6	1078-... adjusted prior to delivery to zero clearance on h5 shaft (lower limit)		dyn. C (N)	stat. C ₀ (N)
30	+21 -10		+15 -5	8500	9520
40	+23 -13		+17 -4	13900	16000
50	+25 -12		+18 -5	20800	24400
60	+26 -15		+23 -4	29500	34100
80	+29 -15		+22 -5	54800	61500

The figures for dynamic load-carrying capacity have been calculated assuming a nominal travel of 100,000 m.

For a nominal travel of 50,000 m, the 'C' figures in the table must be multiplied by a factor of 1.26.

1) Tolerance to DIN 1685-GTB 16

2) Hex. socket head cap screws to DIN 6912-8.8. Applies only for fixing in tapped bores in steel or cast iron.

3) When screwed down, relative to shaft nominal dimension d.

4) The load capacities apply when the load is acting along the line shown by the arrows at F_{H1} or F_{H2}.

STAR – Radial Compact Sets

Radial Sets and Radial Compact Sets provide the same high load-carrying capacity – and hence the same long life service life – as Radial Linear Bushings. Both elements incorporate the design principle of radial ball lift-off at the end of the load-carrying zone. Compared with the time-tested Linear Sets with Radial Linear Bushings, Radial Compact Sets offer decided advantages:

Advantages

- Lower overall height and width.
The compact build was achieved by integrating the housing and the linear bushing into one element.
- Lower weight.
- High dimensional accuracy – closer tolerances
Radial clearance: up to 50% better
Height: up to 25% better
- Fully sealed due to wiper-type seals and axial seal strip in the opening.
- Fitting edge for greater ease of mounting.
- Ready-drilled bores for locating pins.

The Set can be paired with a Precision Steel Shaft and a specially modified Steel Shaft Support Rail (see Chapter "Shaft Support Rails"). This combination affords the machine designer the following benefits:

- Lower and narrower shaft support rail.
- Easy installation for diameters 30 to 50, which can be supplied in one piece with ready-mounted shaft up to a length of 3000 mm.
- Parallelism of shaft relative to mounting base improved by 25%, thus giving more precise guidance over lengths up to 3000 mm in sizes 30 to 50.
- Fitting edge on the shaft support rail to facilitate mounting.

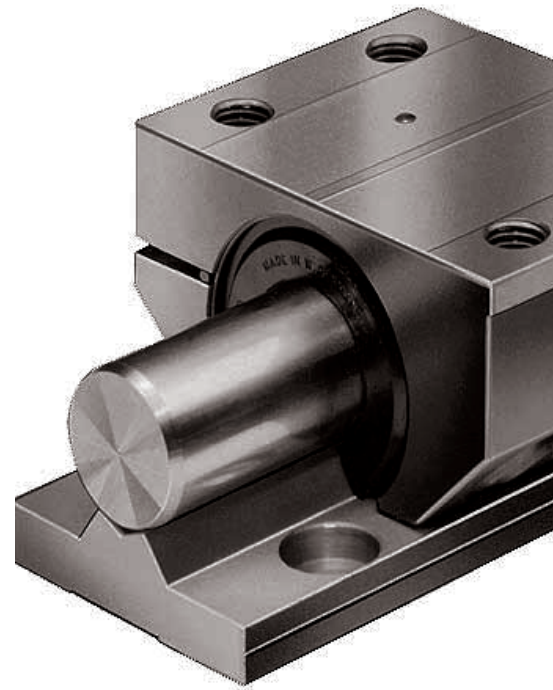

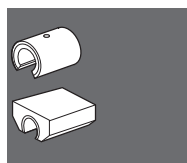
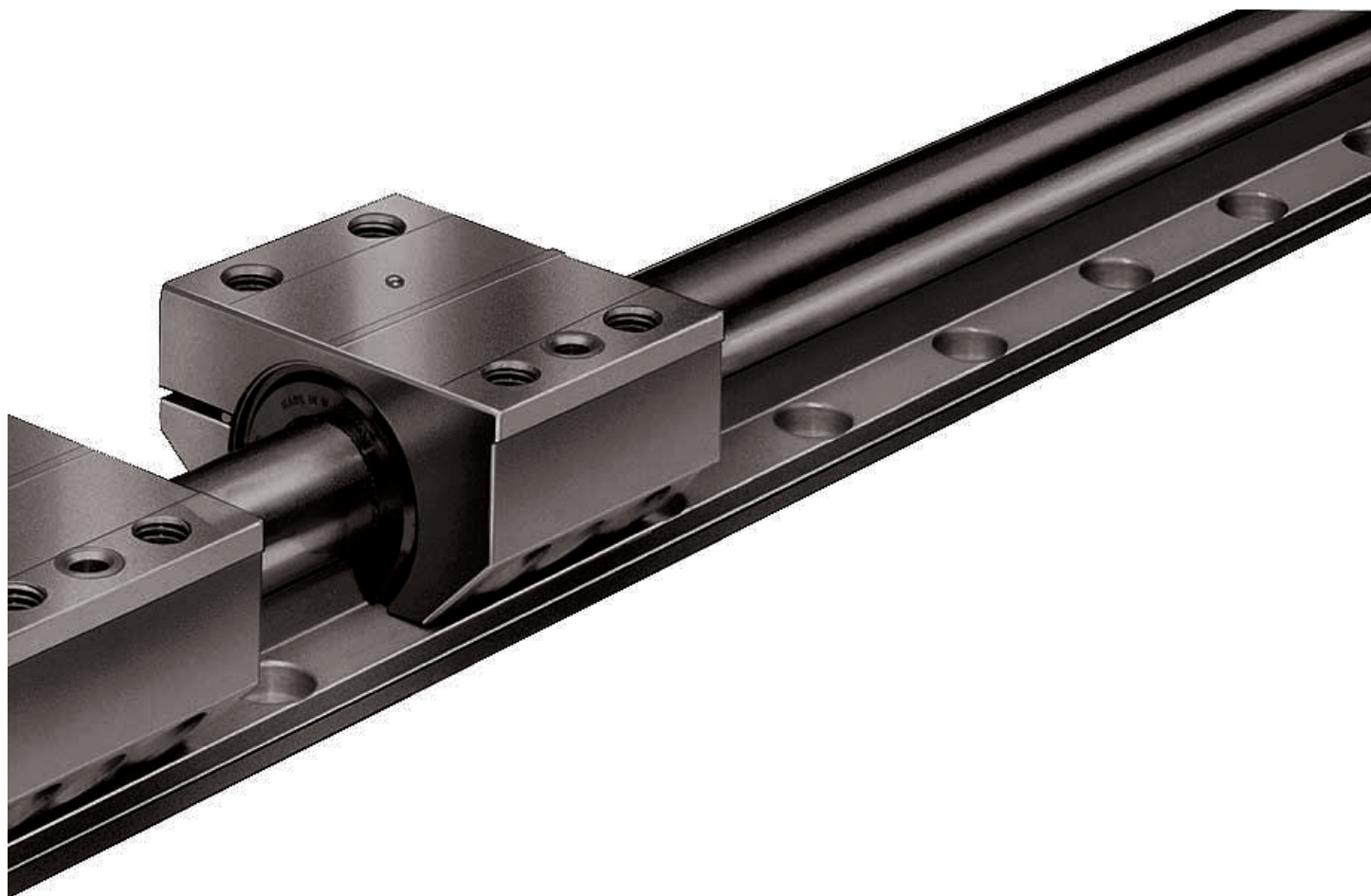

STAR – Radial Compact Sets

Technical Data/Mounting Instructions

Friction, velocity, acceleration, operating temperature and direction of load and its influence on the load capacity and rigidity

The values given for Radial Linear Bushings may be used for design purposes.

Frictional drag for seals without radial loading

Shaft Ø d mm	Breakaway force (N approx.)	Frictional drag (N approx.)
30	24	12
40	32	16
50	40	20
60	48	24
80	60	30

Mounting procedure

Prior to installation

Check the flatness of the base on which the Radial Compact Set is to be mounted, as irregularities will affect the radial clearance. The shaft ends must be chamfered. Take care not to tilt the Radial Compact Sets while pushing them onto the shaft.

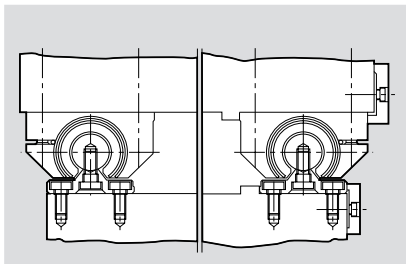

With STAR Shaft Support Rails

see Chapter "Shaft Support Rails".

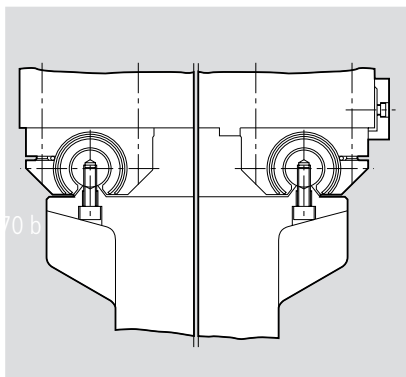

Shaft Support Rails cut to fit the machine base (low overall height)

- Fabricate the shaft support rails to the specified parallelism (see section on "Parallelism, General Technical Data and Mounting Instructions").
- Screw on the shafts.
- Mount the Radial Compact Sets (see Chapter "Shaft Support Rails"). Alternatively, the Radial Compact Sets may be installed according to the Chapter "Shaft Support Rails".

Recommended mounting screws for installation of shaft

Ø d (mm)	30	40	50	60	80
ISO 4762-8.8	M10x30	M12x40	M16x50	M20x60	M24x80

Edge radii, fitting edges and screws

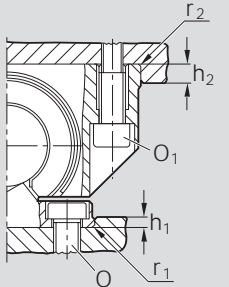

Ø d	Dimensions (mm)						Tightening torque (Nm)	
	r ₁ (max)	h ₁	r ₂ (max)	h ₂	O	O ₁	O	O ₁
					DIN 7984-8.8	ISO 4762-8.8		
30	0.6	6	0.6	6	M10x20	M10x40	32	46
40	0.6	6	0.6	6	M12x25	M12x45	56	80
50	1.2	8	0.6	8	M16x30	M16x60	136	195
60	1.2	8	0.6	16	M20x40	M20x80	270	385
80	1.2	10	0.6	20	M24x50	M24x100	460	660

Mounting of Radial Compact Sets from below

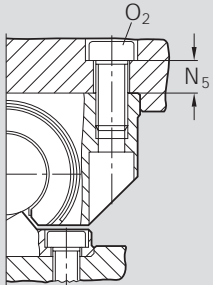

Ø d	Dimensions (mm)		Tightening torque (Nm)
	N ₅	O ₂	
30	17	M12x30	55
40	24	M16x40	100
50	28	M20x50	240
60	30	M27x60	500
80	45	M30x80	800

Locating pins

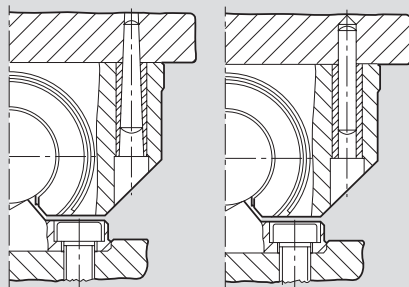

Ø d	Tapered pin (hardened) or cylindrical pin
30	8 x 60
40	10 x 80
50	12 x 100
60	14 x 120
80	16 x 160

Radial clearance

Adjustable Radial Compact Sets are adjusted to zero clearance on a shaft of diameter accurate to a tolerance of h5 (lower limit) prior to delivery.
If a **preload** is required, the procedure is as follows:

- Measure the diameter of the guide shaft.
- Choose a dummy shaft whose diameter is smaller by the amount of the desired preload than the actual guide shaft and insert it.
- Reduce the clearance using the adjusting screw until a slight resistance is felt when the dummy shaft is turned.

Lubricating instructions

Lubricate only with shaft inserted; add lubricant until excess emerges.

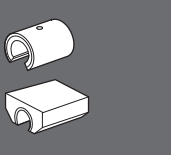

STAR – Radial Compact Sets

Radial Compact Sets, 1611- open type

Radial Compact Sets, 1613- open type, adjustable

Structural Design

- Hardened and ground bearing block made of anti-friction bearing steel
- Reinforced polyamide ball retainer
- Balls made of anti-friction bearing steel
- Two snap rings
- Fully sealed (with internal wiper-type seals and seal strip)

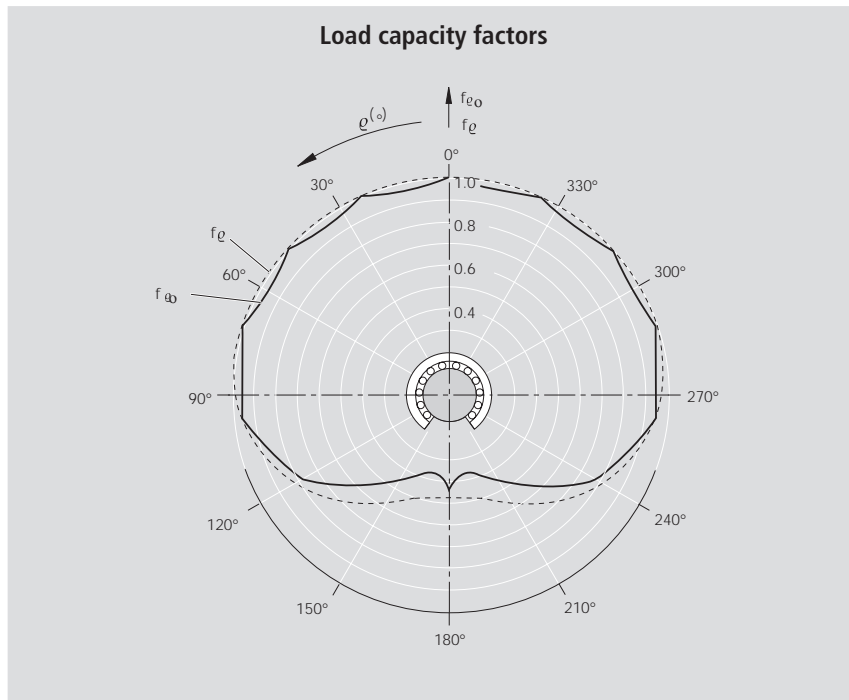

Ordering data



Shaft Ø d (mm)	Part numbers	Mass (kg)
30	1611-300-00	1.75
40	1611-400-00	3.5
50	1611-500-00	7.1
60	1611-600-00	11.9
80	1611-800-00	29.6



Shaft Ø d (mm)	Part numbers	Mass (kg)
30	1613-300-00	1.75
40	1613-400-00	3.5
50	1613-500-00	7.1
60	1613-600-00	11.9
80	1613-800-00	29.6

The figures for dynamic load-carrying capacity have been calculated assuming a nominal travel of 100,000 m. For a nominal travel of 50,000 m, the 'C' figures in the table must be multiplied by a factor of 1.26.

Dimensions

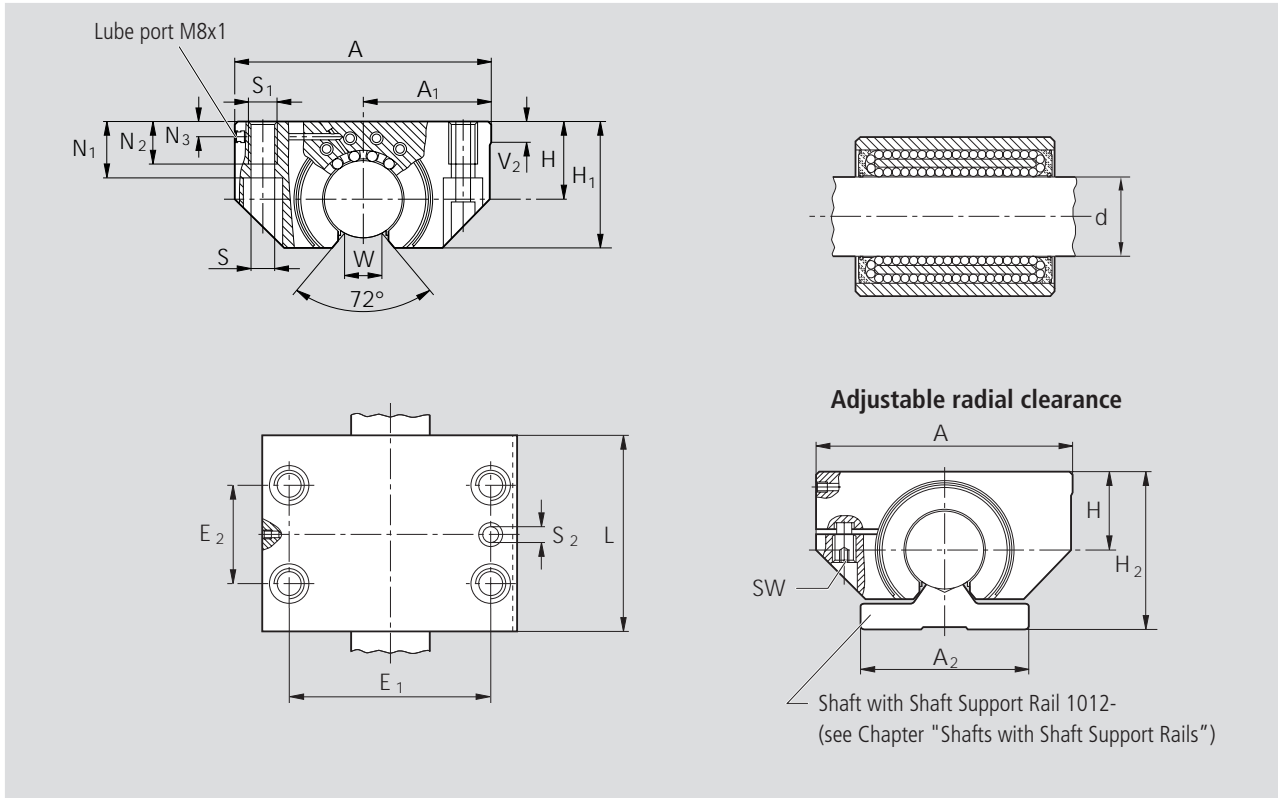

Ø d	Dimensions (mm)																		Radial clearance (µm)		Load capacities ⁴⁾		
	A	A ₁	A ₂	H ¹⁾	H ₁	H ₂	L	E ₁	E ₂	S	S ₁	S ₂ ²⁾	N ₁	N ₂	N ₃	V ₂	W ³⁾	SW	shaft h6	1611-	1613-	dyn.	stat.
		±0.008		±0.008																		C (N)	C ₀ (N)
30	100	50	68	32	53	65	75	76	40	10.5	M12	7.7	21	15	9	6	14	5		+10 -6	adjusted prior to delivery to zero clearance on h5 shaft (lower limit)	8500	9520
40	125	62.5	85	40	66	80	100	94	50	13.8	M16	9.7	27	18	11	6	19.5	6		+12 -7		13900	16000
50	160	80	105	50	81.5	100	125	122	65	17.5	M20	11.7	35	24	12	8	24.5	8		+12 -7		20800	24400
60	190	95	130	60	97	120	150	150	75	22	M27	13.7	42	32	13	16	29	10		+15 -9		29500	34100
80	260	130	170	80	130	160	200	205	100	26	M30	15.7	57	36	15	16	39	12		+15 -9		54800	61500

- 1) When screwed down, relative to shaft nominal dimension d.
- 2) Pre-drilled bores for locating pins.
- 3) Lower limit relative to shaft nominal dimension d.
- 4) The load capacities apply when the load is acting along the line $\varrho = 0^\circ$.

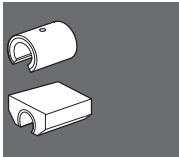

STAR – Torque-Resistant Linear Bushings

The Torque-Resistant Linear Bushing makes it possible to obtain axially and radially true linear motion with just one shaft. Its space-saving design makes it suitable for use in numerous jig and special-purpose machinery applications.

Torque-Resistant Linear Bushings

Torque-Resistant Linear Bushings are similar in their structural design to the already familiar Super Linear Bushings . The torque is transmitted between extra-deep ball races with special hardened steel load bearing plates in the linear bushings and ball guide grooves in the precision steel shaft. Two types are available: Type 1 with one ball guide groove and Type 2 with two ball guide grooves. The type required for any given application will depend on the magnitude of the torque to be transmitted.

Linear Sets with Torque-Resistant Linear Bushings

The version with a steel housing is extremely sturdy. The comparatively low weight of the high-strength aluminum housing is of great advantage wherever applications call for higher acceleration and faster positioning speeds. The aluminum version is lubricatable. This makes them ideal for use in many branches of mechanical and tool engineering and handling technology.

The advantages:

Compact block design

The Torque-Resistant Linear Bushing is completely enclosed in the compact housing to protect it against all external impacts.

Easy to mount

with only two mounting screws. No need to align two shafts in parallel. No reduction of service life due to out-of-parallelism.

High precision

and trouble-free running thanks to the high-strength housing design and integral Torque-Resistant Linear Bushing.

Zero-clearance guidance

The steel load bearing plates that transmit the torque are adjusted to zero clearance by means of the adjusting screws before the Linear Sets leave the factory.

Torque-Resistant Compact Linear Bushings

Torque-Resistant Compact Linear Bushings have the same basic structural design as Torque-Resistant Linear Bushings, the one difference being the adjusting screws and lock nuts. These are even smaller in order to reduce the overall dimensions still further to allow mounting in narrower sleeves.

Linear Sets with Torque-Resistant Compact Linear Bushings

Linear Sets with Torque-Resistant Compact Linear Bushings are self-contained units comprising a Torque-Resistant Compact Linear Bushing and a sleeve. When mounted in tandem they provide stability in applications with cocking loads, thus allowing higher permissible torque levels. A version with a flanged housing is also available.



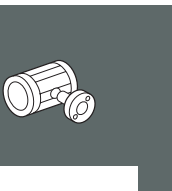

STAR – Torque-Resistant Linear Bushings Overview

Torque-Resistant Linear Bushings

Type 1

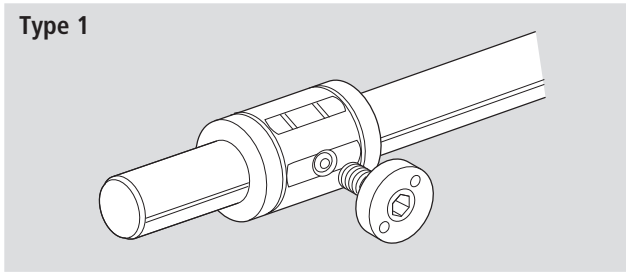

with one ball guide groove

Type 2

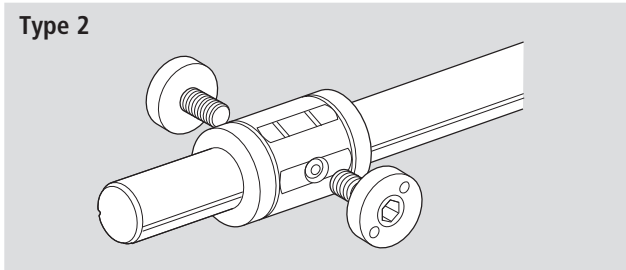

with two ball guide grooves

Torque-Resistant Compact Linear Bushing

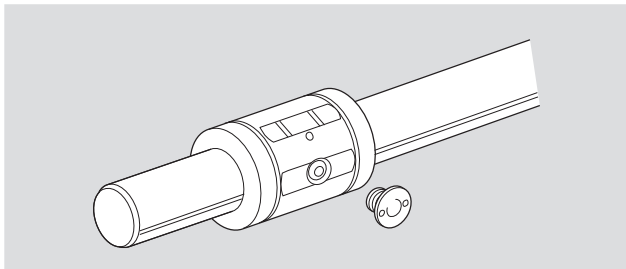

Technical Data

Please observe the general technical principles and mounting instructions at the beginning of this catalog as well as the additional technical data given below.

Operating temperature up to 100 °C

Reduced load capacity in short-stroke applications In short-stroke applications, the service life of the shafts is shorter than that of the Torque-Resistant Linear Bushings.

For this reason, the load capacities C listed in the tables must be multiplied by the factor f_w .

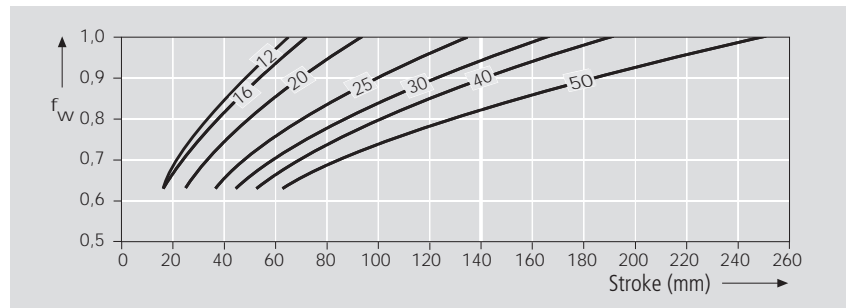

Load capacity and travel life

In applications subject to superimposed radial loads and torque, the equivalent total load must first be calculated for use in the travel life calculation.

$$L = F_R + \frac{C \cdot M}{M_t}$$

$$L = \left(\frac{C}{F}\right)^3 \cdot 10^5 \text{ m}$$

F = equivalent total load (N)

F_R = radial load (N)

C = dynamic load capacity

M = torque (Nm)

M_t = torque (catalog rating) (Nm)

L = travel life

In applications subject to torque only, travel life is calculated as follows:

$$L = \left(\frac{M_t}{M}\right)^3 \cdot 10^5 \text{ m}$$

M = torque (Nm)

M_t = torque (catalog rating) (Nm)

$M_1, M_2 \dots M_n$ = discrete torque steps (Nm)

$q_1, q_2 \dots q_n$ = percentage stroke covered under $M_1, M_2 \dots M_n$ (%)

$$M = \sqrt[3]{M_1^3 \cdot \frac{q_1}{100} + M_2^3 \cdot \frac{q_2}{100} + \dots + M_n^3 \cdot \frac{q_n}{100}}$$

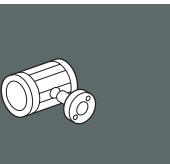

Straightness of shaft

- up to 1200 mm length: 0.1 mm
- at 2000 mm length: 0.2 mm

Stability against cocking loads

To ensure stability against cocking loads it is expedient to install two Torque-Resistant Linear Bushings.

In the case of Linear Sets, we recommend the Tandem version (with two Torque-Resistant Linear Bushings).

STAR – Torque-Resistant Linear Bushings

Mounting of Torque-Resistant Linear Bushings

Mounting procedure

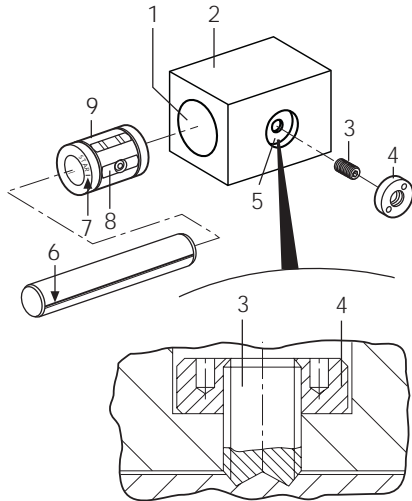

⚠ Linear Sets are ready-mounted and adjusted to zero clearance. If the shaft has been removed, it is necessary to loosen the adjusting screws and re-adjust the Torque-Resistant Linear Bushing.

- Chamfer and clean the bore (1) in the housing (2).
- Oil the adjusting screw (3).
- Check the lock nut (4) on the adjusting screw (3) for ease of movement.
- Check the adjusting screw (3) in the tapped hole (5) for ease of movement. Deburr thread runout, if necessary.
- Remove transport packing from the linear bushing.

⚠ Do not drive in linear bushings with a hammer!

- Insert linear bushing (9) in the housing (2) by hand.
- Align countersunk steel bearing plate (8) with the tapped hole (5) in the housing.
- Align one ball guide groove (6) with the marking (7) on the identification block of the linear bushing.
- Insert shaft, **taking care not to tilt it!**

Adjustment of adjusting screws

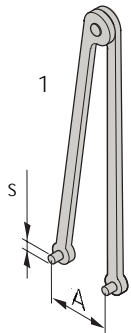

- Screw in adjusting screw until it meets with initial resistance.
- Move shaft to and fro, while simultaneously attempting to turn it in both directions. Tighten adjusting screw with hex. wrench.
- For type 1 (one ball guide groove), tighten adjusting screw to M_{GA} .
- For type 2 (two ball guide grooves), first tighten one adjusting screw to $M_{GA}/2$, then the other to M_{GA} .
- Secure adjusting screw with lock nut. Use face wrench (1). The adjusting screw must not turn when being secured with the lock nut. Tightening torque = M_{GK} .
- After mounting, the frictional drag F_R should be as shown in the table below. If the frictional drag varies significantly, loosen and re-adjust adjusting screws!
- **Do not remove shaft!**

Shaft diameter	(mm)	12	16	20	25	30	40	50	
Face wrench (1)	s	(mm)	2.5	2.5	3	3	3	3	
	A	(mm)	10	10	15	15	19.5	19.5	25
Tightening torque	adjusting screw M_{GA}	(Ncm)	8	11	30	45	70	100	180
	lock nut M_{GK}	(Ncm)	400	400	1500	1500	2000	2000	3000
Frictional drag F_R approx. (one linear bushing)	(N)	1.5	2	3	4.5	6	8	12	

Installation of seal

- Push seal onto the shaft, aligning the lip with the groove.
- Press seal into the mounting bore.

With each installed seal the frictional drag rises higher than the value F_R . If two seals are installed, it increases to roughly three times the value stated in the table.

Mounting of Torque-Resistant Compact Linear Bushings

Mounting procedure

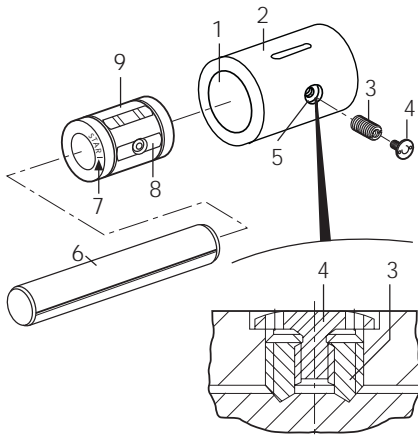

⚠ Linear Sets are ready-mounted and adjusted to zero clearance. If the shaft has been removed, it is necessary to loosen the adjusting screws and re-adjust the Torque-Resistant Compact Linear Bushing.

- Chamfer and clean the bore (1) in the housing (2).
- Oil the adjusting screw (3) and lock screw (4).
- Check the lock screw (4) in the adjusting screw (3) for ease of movement.
- Check the adjusting screw (3) in the tapped hole (5) for ease of movement. Deburr thread runout, if necessary.
- Remove transport packing from the linear bushing.

⚠ Do not drive in linear bushings with a hammer!

- Insert linear bushing (9) in the housing (2) by hand.
- Align countersunk steel bearing plate (8) with the tapped hole (5) in the housing.
- Align one ball guide groove (6) with the marking (7) on the identification block of the linear bushing.
- Insert shaft, **taking care not to tilt it!**

Adjustment of adjusting screws

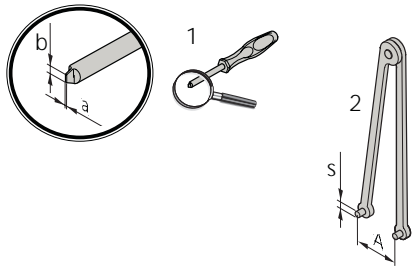

- Screw in adjusting screw until it meets with initial resistance.
- Move shaft to and fro, while simultaneously attempting to turn it in both directions. Tighten adjusting screw with screwdriver (1).
- For shaft diameters 12 and 16, tighten adjusting screw to M_{GA} .
- For shaft diameters 20 to 50, first tighten one adjusting screw to $M_{GA}/2$, then the other to M_{GA} .
- Using a face wrench (2), insert lock screw into the adjusting screw and tighten to tightening torque M_{GK} .
- After mounting, the frictional drag F_R should be as shown in the table below. If the frictional drag varies significantly, loosen and re-adjust adjusting screws!
- **Do not remove shaft!**

Shaft diameter		(mm)	12	16	20	25	30	40	50
Screw driver (1)	a	(mm)	0.8	0.8	1	1	1.2	1.2	1.6
	b	(mm)	5	5	8	8	10	10	14
Face wrench(2)	s	(mm)	1.5	1.5	2	2	2.5	2.5	3
	A	(mm)	5.5	5.5	8	8	10	10	13
Tightening torque	adjusting screw	M_{GA} (Ncm)	8	11	30	45	70	100	180
	lock screw	M_{GK} (Ncm)	110	110	180	380	800	800	1300
Frictional drag F_R approx. (one linear bushing)		(N)	1.5	2	3.8	5.6	7.5	10	15

Installation of seal

- Push seal onto the shaft, aligning the lip with the groove.
- Press seal into the mounting bore.

With each installed seal the frictional drag rises higher than the value F_R . If two seals are installed, it increases to roughly three times the value stated in the table.

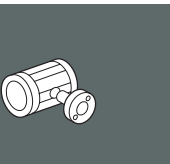

STAR – Torque-Resistant Linear Bushings

Torque-Resistant Linear Bushings, 0696-0..-

Type 1: one ball guide groove

Torque-Resistant Linear Bushings, 0696-3..-

Type 2: two ball guide grooves

Structural design

- Plastic ball retainer and outer sleeve
- Hardened steel load bearing plates
- Balls made of anti-friction bearing steel
- Precision Steel Shaft with ball guide groove
- Hardened steel adjusting screw
- Steel lock nut

Ordering data



Shaft Ø d (mm)	Part numbers Torque-Resistant Linear Bushing with shaft					
	standard length as per table	shaft length 900 mm	shaft length 1200 mm	shaft length 2000 mm	shaft to specified length ¹⁾	customized shaft
12	0696-012-80	0696-012-85	0696-012-87	0696-012-88	0696-012-89	0696-012-86
16	0696-016-80	0696-016-85	0696-016-87	0696-016-88	0696-016-89	0696-016-86
20	0696-020-80	0696-020-85	0696-020-87	0696-020-88	0696-020-89	0696-020-86
25	0696-025-80	0696-025-85	0696-025-87	0696-025-88	0696-025-89	0696-025-86
30	0696-030-80	0696-030-85	0696-030-87	0696-030-88	0696-030-89	0696-030-86
40	0696-040-80	0696-040-85	0696-040-87	0696-040-88	0696-040-89	0696-040-86
50	0696-050-80	0696-050-85	0696-050-87	0696-050-88	0696-050-89	0696-050-86

Part numbers for Torque-Resistant Linear Bushing without shaft: 0696-0..-00



Shaft Ø d (mm)	Part numbers Torque-Resistant Linear Bushing with shaft					
	standard length as per table	shaft length 900 mm	shaft length 1200 mm	shaft length 2000 mm	shaft to specified length ¹⁾	customized shaft
20	0696-320-80	0696-320-85	0696-320-87	0696-320-88	0696-320-89	0696-320-86
25	0696-325-80	0696-325-85	0696-325-87	0696-325-88	0696-325-89	0696-325-86
30	0696-330-80	0696-330-85	0696-330-87	0696-330-88	0696-330-89	0696-330-86
40	0696-340-80	0696-340-85	0696-340-87	0696-340-88	0696-340-89	0696-340-86
50	0696-350-80	0696-350-85	0696-350-87	0696-350-88	0696-350-89	0696-350-86

Part numbers for Torque-Resistant Linear Bushing without shaft: 0696-3..-00

¹⁾ Also available with tubular shaft: 0696-...-69 or with corrosion-resistant steel shaft to DIN 17230 / EN 10088: 0696-...-79.



Shaft Ø d (mm)	Part numbers	
	seal Type 1	seal Type 2
12	1331-112-00	–
16	1331-116-00	–
20	1331-120-00	1331-320-00
25	1331-125-00	1331-325-00
30	1331-130-00	1331-330-00
40	1331-140-00	1331-340-00
50	1331-150-00	1331-350-00

The seal must be ordered separately.

Dimensions

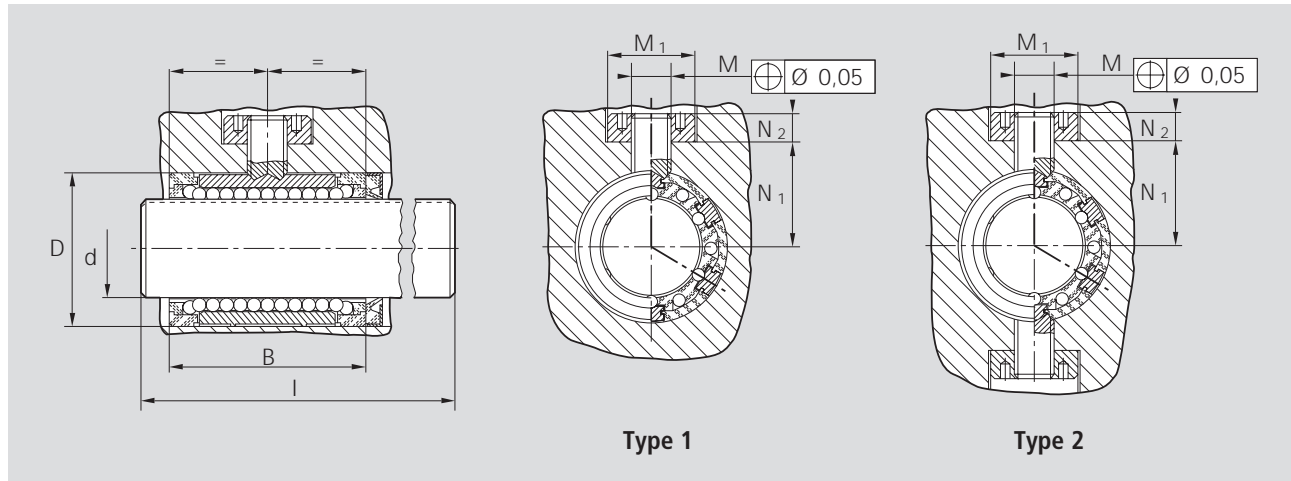

Ø d		Dimensions (mm)							Standard shaft l (mm)	Torque M_t		Load capacities ²⁾		Mass	
		Type 1	Type 2	D ¹⁾	B	M	M ₁	N ₁ +0.1		N ₂	Type 1 (Nm)	Type 2 (Nm)	C (N)	C ₀ (N)	linear bushing (kg)
12	–	22	32	M6x0.5	14	15.5	5	400	2	–	640	420	0.026	0.89	
16	–	26	36	M6x0.5	14	19.5	5	400	3.3	–	780	530	0.032	1.57	
20	20	32	45	M10x1	22	21.5	8	500	7.5	12	1550	1050	0.064	2.45	
25	25	40	58	M10x1	22	28.5	8	500	15	24	3030	2180	0.135	3.80	
30	30	47	68	M12x1	26	32	9.5	600	23	37	3680	2790	0.210	5.50	
40	40	62	80	M12x1	26	44	9.5	600	53	86	6320	4350	0.390	9.80	
50	50	75	100	M16x1.5	34	52	12.5	600	103	167	9250	6470	0.680	15.30	

¹⁾ Recommended mounting bore: D⁵⁷

²⁾ The load capacities stated are minimum values as the position and direction of load cannot always be precisely defined.

Seal with metal case

Ø d	Dimensions (mm)	
	D ³⁾	b
12	22	3
16	26	3
20	32	4
25	40	4
30	47	5
40	62	5
50	75	6

³⁾ The outer diameter D is about 0.1 mm oversize. No retaining elements required.

The figures for dynamic load-carrying capacity have been calculated assuming a nominal travel of 100,000 m. For a nominal travel of 50,000 m, the 'C' figures in the table must be multiplied by a factor of 1.26.

STAR – Torque-Resistant Compact Linear Bushings

Torque-Resistant Compact Linear Bushings, 0720-

Structural design

- Plastic ball retainer and outer sleeve
- Hardened steel load bearing plates
- Balls made of anti-friction bearing steel
- Precision Steel Shaft with ball guide groove
- Hardened steel adjusting screw
- Steel lock screw

One ball guide groove for shaft diameter d = 12 and 16 mm

Two ball guide grooves for shaft diameter d = 20 mm and over

Ordering data



Shaft Ø d (mm)	Part numbers Torque-Resistant Compact Linear Bushing with shaft					
	standard length as per table	shaft length 900 mm	shaft length 1200 mm	shaft length 2000 mm	shaft to specified length ¹⁾	customized shaft
12	0720-012-80	0720-012-85	0720-012-87	0720-012-88	0720-012-89	0720-012-86
16	0720-016-80	0720-016-85	0720-016-87	0720-016-88	0720-016-89	0720-016-86
20	0720-320-80	0720-320-85	0720-320-87	0720-320-88	0720-320-89	0720-320-86
25	0720-325-80	0720-325-85	0720-325-87	0720-325-88	0720-325-89	0720-325-86
30	0720-330-80	0720-330-85	0720-330-87	0720-330-88	0720-330-89	0720-330-86
40	0720-340-80	0720-340-85	0720-340-87	0720-340-88	0720-340-89	0720-340-86
50	0720-350-80	0720-350-85	0720-350-87	0720-350-88	0720-350-89	0720-350-86

Part numbers for Torque-Resistant Compact Linear Bushing without shaft:

Size Ø 12 and 16: 0720-0..-00
Size Ø 20 to 50: 0720-3..-00

¹⁾ Also available with tubular shaft: 0720-...-69 or with corrosion-resistant steel shaft to DIN 17230 / EN 10088: 0720-...-79.

separate seals



Shaft Ø d (mm)	Part numbers
12	1331-112-00
16	1331-116-00
20	1331-320-00
25	1331-325-00
30	1331-330-00
40	1331-340-00
50	1331-350-00

The seal must be ordered separately.

Dimensions

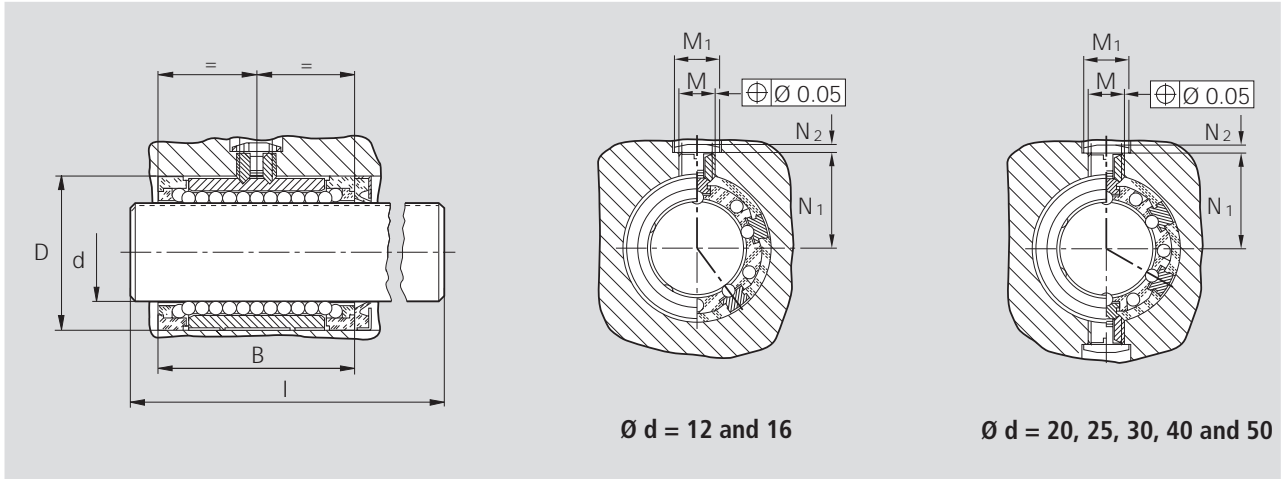

Ø d	Dimensions (mm)						Standard shaft l (mm)	Torque M_t (Nm)	Load capacities ²⁾		Mass	
	D ¹⁾	B	M	M ₁	N ₁ +0.1	N ₂			dyn. C (N)	stat. C ₀ (N)	linear bushing (kg)	shaft (kg/m)
12	22	32	M6x0.5	8	14.4	1.3	400	2	640	420	0.026	0.89
16	26	36	M6x0.5	8	16.4	1.3	400	3.3	780	530	0.032	1.57
20	32	45	M10x1	12.5	21.8	1.9	500	12	1550	1050	0.071	2.45
25	40	58	M10x1	12.5	25.8	1.9	500	24	3030	2180	0.130	3.80
30	47	68	M12x1	15	29.7	2.5	600	37	3680	2790	0.200	5.50
40	62	80	M12x1	15	37.2	2.5	600	86	6320	4350	0.380	9.80
50	75	100	M16x1.5	20	46.7	3	600	167	9250	6470	0.620	15.30

¹⁾ Recommended mounting bore: D^{K6}

²⁾ The load capacities stated are minimum values as the position and direction of load cannot always be precisely defined.

Seal with metal case

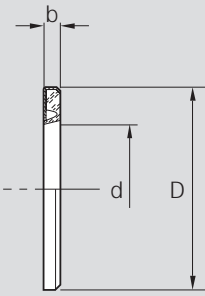

Ø d	Dimensions (mm)	
	D ³⁾	b
12	22	3
16	26	3
20	32	4
25	40	4
30	47	5
40	62	5
50	75	6

³⁾ The outer diameter D is about 0.1 mm oversize. No retaining elements required.

The figures for dynamic load-carrying capacity have been calculated assuming a nominal travel of 100,000 m. For a nominal travel of 50,000 m, the 'C' figures in the table must be multiplied by a factor of 1.26.

STAR – Linear Sets with Torque-Resistant Linear Bushings

Overview/Mounting Instructions

Linear Sets with Torque-Resistant Linear Bushings, aluminum version

Type 1: one ball guide groove

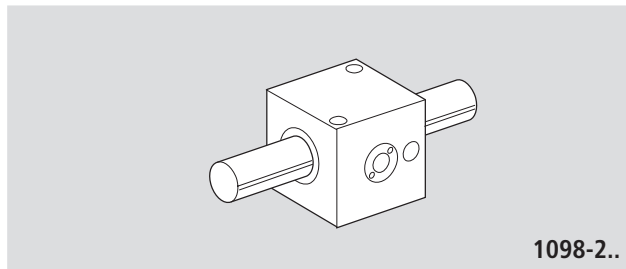

Type 2: two ball guide grooves

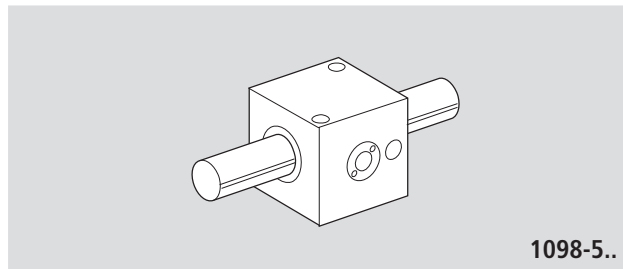

Tandem Linear Set

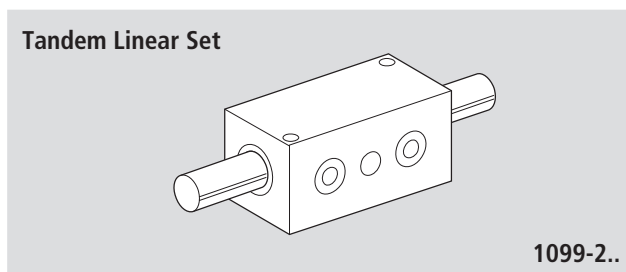

Tandem Linear Set

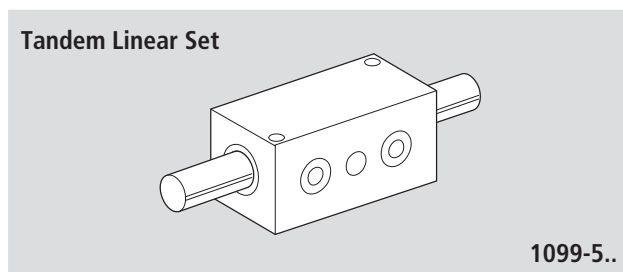

Linear Sets with Torque-Resistant Linear Bushings, steel version

Type 1: one ball guide groove

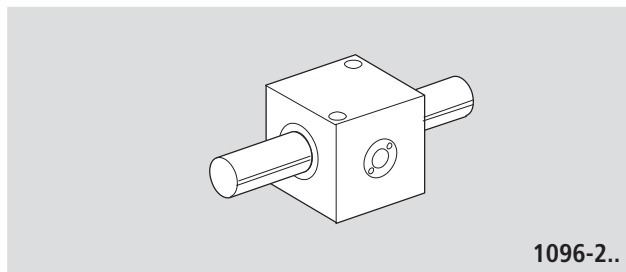

Type 2: two ball guide grooves

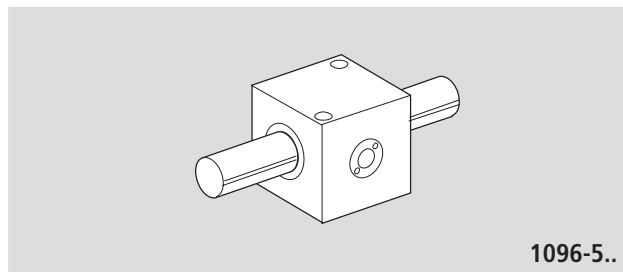

Tandem Linear Set

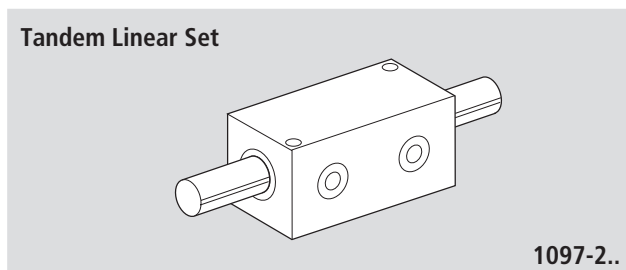

Tandem Linear Set

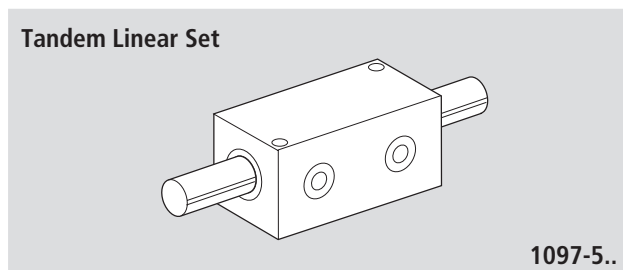

Linear Sets with Torque-Resistant Compact Linear Bushings, sleeve design

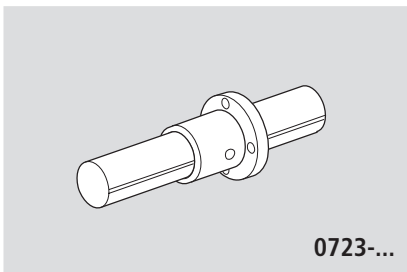
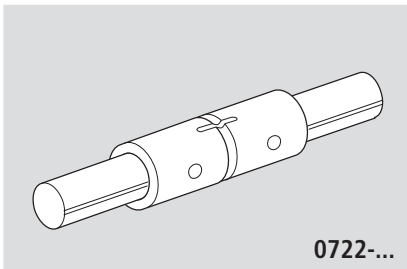
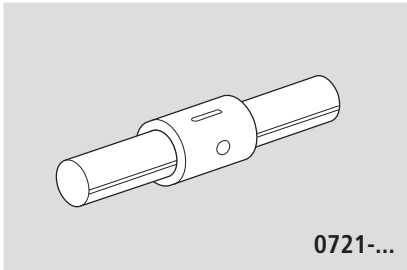

Mounting procedure



Linear Sets are ready-mounted and adjusted to zero clearance. If the shaft has been removed, it is necessary to loosen the adjusting screws and re-adjust the Torque-Resistant Linear Bushing.

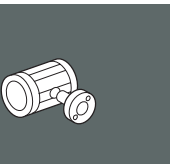

STAR – Linear Sets incorporating one Torque-Resistant Linear Bushing

Linear Sets - aluminum, 1098-2.-

Type 1: one ball guide groove

Linear Sets - aluminum, 1098-5.-

Type 2: two ball guide grooves

Structural design

- Precision Housing, lightweight series, (aluminum)
- Torque-Resistant Linear Bushing
- Precision Steel Shaft with ball guide groove
- Torque-transmitting steel load bearing plates adjusted to zero clearance before leaving the factory
- External seals
- Stability against cocking loads: see Linear Sets, Tandem version
- 1 or 2 ball guide grooves
- Lubricatable

Ordering data



Shaft Ø d (mm)	Part numbers Linear Set with Torque-Resistant Linear Bushing and shaft					
	standard length as per table	shaft length 900 mm	shaft length 1200 mm	shaft length 2000 mm	shaft to specified length ¹⁾	customized shaft
12	1098-212-80	1098-212-85	1098-212-87	1098-212-88	1098-212-89	1098-212-86
16	1098-216-80	1098-216-85	1098-216-87	1098-216-88	1098-216-89	1098-216-86
20	1098-220-80	1098-220-85	1098-220-87	1098-220-88	1098-220-89	1098-220-86
25	1098-225-80	1098-225-85	1098-225-87	1098-225-88	1098-225-89	1098-225-86
30	1098-230-80	1098-230-85	1098-230-87	1098-230-88	1098-230-89	1098-230-86
40	1098-240-80	1098-240-85	1098-240-87	1098-240-88	1098-240-89	1098-240-86
50	1098-250-80	1098-250-85	1098-250-87	1098-250-88	1098-250-89	1098-250-86



Shaft Ø d (mm)	Part numbers Linear Set with Torque-Resistant Linear Bushing and shaft					
	standard length as per table	shaft length 900 mm	shaft length 1200 mm	shaft length 2000 mm	shaft to specified length ¹⁾	customized shaft
20	1098-520-80	1098-520-85	1098-520-87	1098-520-88	1098-520-89	1098-520-86
25	1098-525-80	1098-525-85	1098-525-87	1098-525-88	1098-525-89	1098-525-86
30	1098-530-80	1098-530-85	1098-530-87	1098-530-88	1098-530-89	1098-530-86
40	1098-540-80	1098-540-85	1098-540-87	1098-540-88	1098-540-89	1098-540-86
50	1098-550-80	1098-550-85	1098-550-87	1098-550-88	1098-550-89	1098-550-86

¹⁾ Also available with tubular shaft: 1098-...-69 or with corrosion-resistant steel shaft to DIN 17230 / EN 10088: 1098-...-79.

Dimensions

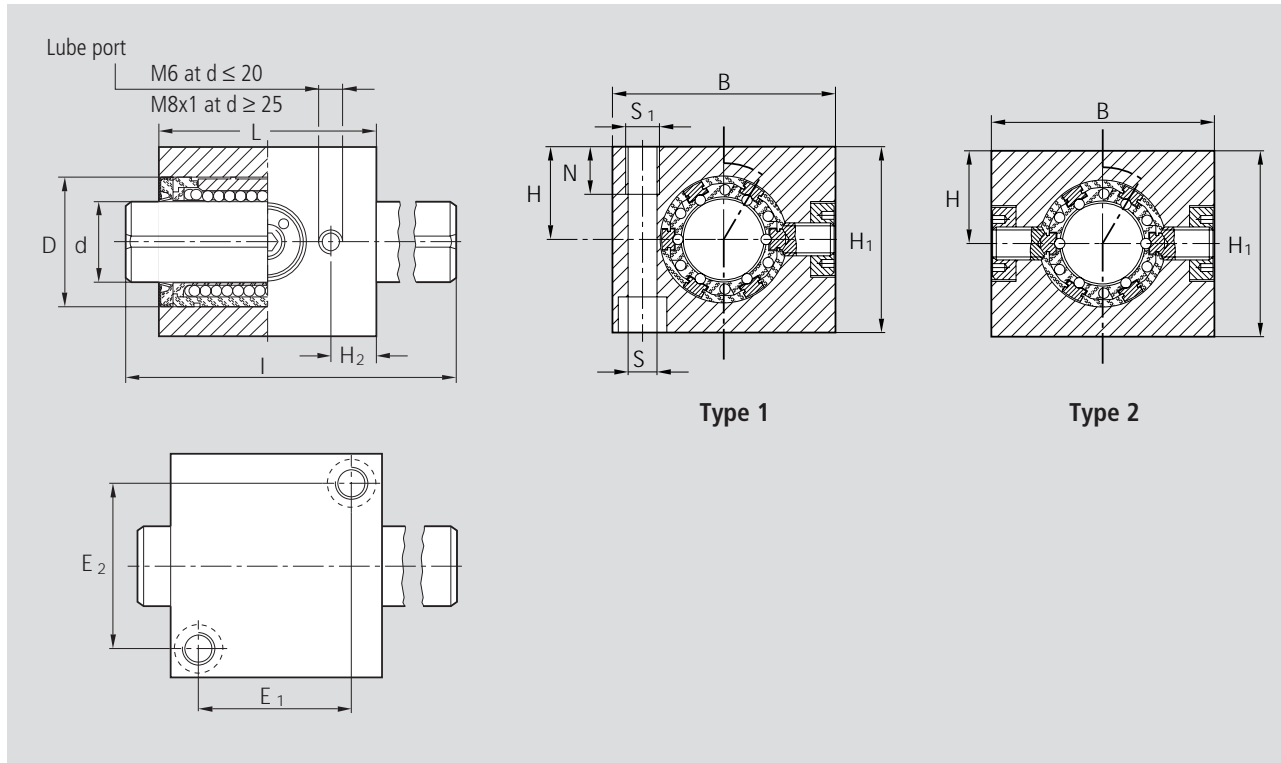

Ø d		Dimensions (mm)											Standard shaft l	Torque M_t		Load capacities ³⁾		Mass	
		Type 1	Type 2	B	H ₁	H ¹⁾ +0.013 -0.022	H ₂	L	D	E ₁	E ₂	S ²⁾		S ₁	N	Type 1	Type 2	dyn. C	stat. C ₀
12	–	42	35	18	8.5	40	22	28	30	5.3	M6	12	400	2	–	640	420	0.15	0.89
16	–	50	42	22	10	44	26	30	36	5.3	M6	12	400	3.3	–	780	530	0.22	1.57
20	20	60	50	25	11	55	32	39	44	6.4	M8	12	500	7.5	12	1550	1050	0.42	2.45
25	25	74	60	30	15.5	68	40	48	54	8.4	M10	15	500	15	24	3030	2180	0.7	3.80
30	30	84	70	35	16.5	80	47	58	62	10.5	M12	18	600	23	37	3680	2790	1.1	5.50
40	40	108	90	45	18.5	92	62	64	80	13.5	M16	20	600	53	86	6320	4350	2.1	9.80
50	50	130	105	50	22.5	114	75	84	100	13.5	M16	20	600	103	167	9250	6470	3.5	15.30

¹⁾ If two or more Linear Sets are mounted on the same shaft, they are leveled to the same dimension H by grinding after mounting. Dimension H is then 0.5 mm smaller.

²⁾ Mounting screws to ISO 4762-8.8.

³⁾ The load capacities stated are minimum values as the position and direction of load cannot always be precisely defined.

Lubricating instructions: Lubricate only when shaft inserted, add lubricant through lube port until excess emerges.

The figures for dynamic load-carrying capacity have been calculated assuming a nominal travel of 100,000 m. For a nominal travel of 50,000 m, the 'C' figures in the table must be multiplied by a factor of 1.26.

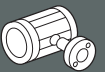

STAR – Linear Sets with Torque-Resistant Linear Bushings

Tandem version

Linear Sets – aluminum, 1099-2..-

Type 1: one ball guide groove

Linear Sets – aluminum, 1099-5..-

Type 2: two ball guide grooves

Structural design

- Precision Tandem Housing, lightweight series, (aluminum)
- Two Torque-Resistant Linear Bushings
- Precision Steel Shaft with ball guide groove
- Torque-transmitting steel load bearing plates adjusted to zero clearance before leaving the factory
- External seals
- Stability against cocking loads
- 1 or 2 ball guide grooves
- Lubricatable

Ordering data

Type 1: one ball guide groove



Shaft Ø d (mm)	Part numbers Linear Set with Torque-Resistant Linear Bushing and shaft					
	standard length as per table	shaft length 900 mm	shaft length 1200 mm	shaft length 2000 mm	shaft to specified length ¹⁾	customized shaft
12	1099-212-80	1099-212-85	1099-212-87	1099-212-88	1099-212-89	1099-212-86
16	1099-216-80	1099-216-85	1099-216-87	1099-216-88	1099-216-89	1099-216-86
20	1099-220-80	1099-220-85	1099-220-87	1099-220-88	1099-220-89	1099-220-86
25	1099-225-80	1099-225-85	1099-225-87	1099-225-88	1099-225-89	1099-225-86
30	1099-230-80	1099-230-85	1099-230-87	1099-230-88	1099-230-89	1099-230-86
40	1099-240-80	1099-240-85	1099-240-87	1099-240-88	1099-240-89	1099-240-86
50	1099-250-80	1099-250-85	1099-250-87	1099-250-88	1099-250-89	1099-250-86

Type 2: two ball guide grooves



Shaft Ø d (mm)	Part numbers Linear Set with Torque-Resistant Linear Bushing and shaft					
	standard length as per table	shaft length 900 mm	shaft length 1200 mm	shaft length 2000 mm	shaft to specified length ¹⁾	customized shaft
20	1099-520-80	1099-520-85	1099-520-87	1099-520-88	1099-520-89	1099-520-86
25	1099-525-80	1099-525-85	1099-525-87	1099-525-88	1099-525-89	1099-525-86
30	1099-530-80	1099-530-85	1099-530-87	1099-530-88	1099-530-89	1099-530-86
40	1099-540-80	1099-540-85	1099-540-87	1099-540-88	1099-540-89	1099-540-86
50	1099-550-80	1099-550-85	1099-550-87	1099-550-88	1099-550-89	1099-550-86

¹⁾ Also available with tubular shaft: 1099-...-69 or with corrosion-resistant steel shaft to DIN 17230 / EN 10088: 1099-...-79.

Dimensions

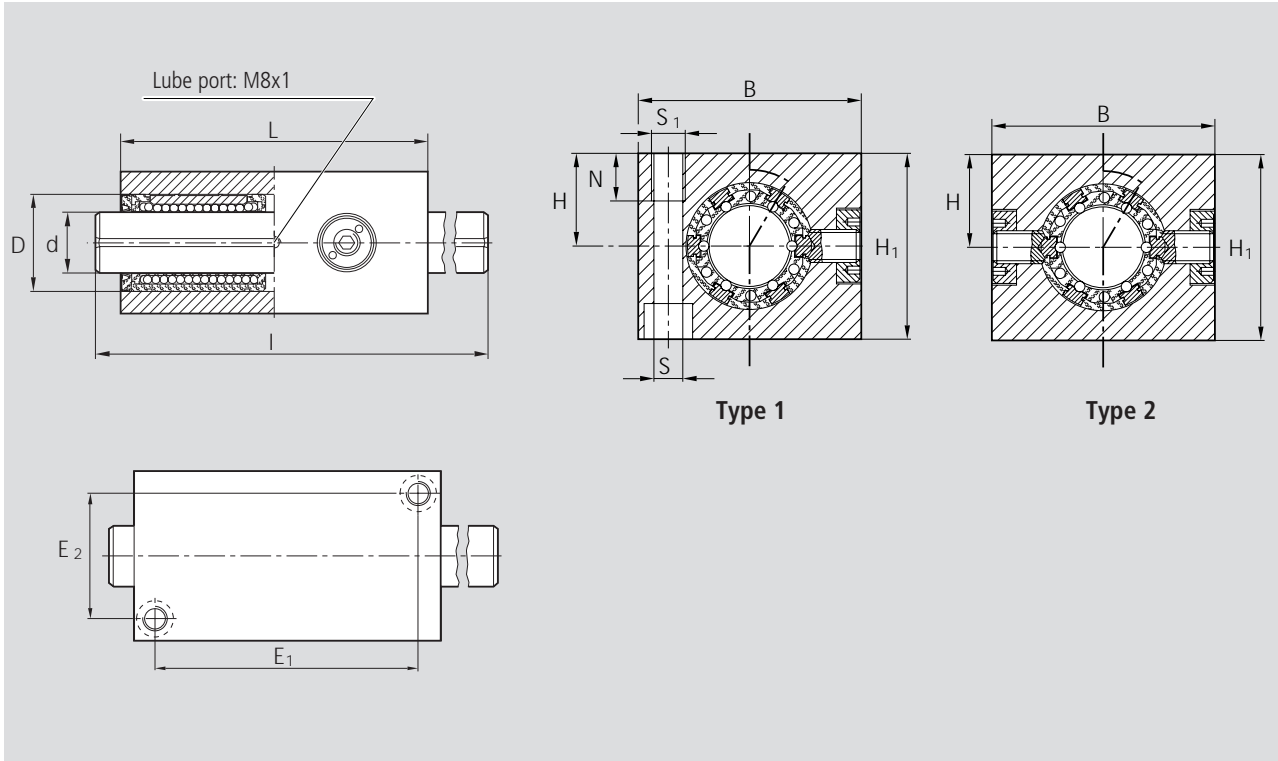

Ø d		Dimensions (mm)										Standard shaft I (mm)	Torque M_t		Load capacities ³⁾		Mass	
		Type 1	Type 2	B	H ₁	H ¹⁾ +0.013 -0.022	L	D	E ₁	E ₂	S ²⁾		S ₁	N	Type 1 (Nm)	Type 2 (Nm)	dyn. C (N)	stat. C ₀ (N)
12	-	42	35	18	76	22	64	30	5.3	M6	12	400	3.2	-	1040	840	0.29	0.89
16	-	50	42	22	84	26	70	36	5.3	M6	12	400	5.5	-	1260	1060	0.43	1.57
20	20	60	50	25	104	32	88	44	6.4	M8	12	500	12	20	2500	2100	0.8	2.45
25	25	74	60	30	130	40	110	54	8.4	M10	15	500	24	40	4900	4360	1.5	3.80
30	30	84	70	35	152	47	130	62	10.5	M12	18	600	37	60	6000	5580	2.2	5.50
40	40	108	90	45	176	62	148	80	13.5	M16	20	600	86	140	10200	8700	4.0	9.80
50	50	130	105	50	224	75	194	100	13.5	M16	20	600	167	272	15000	12940	6.9	15.30

¹⁾ If two or more Linear Sets are mounted on the same shaft, they are leveled to the same dimension H by grinding after mounting. Dimension H is then 0.5 mm smaller.

²⁾ Mounting screws to ISO 4762-8.8.

³⁾ Load capacity, when both linear bushings are subject to equal loading.

The load capacities stated are minimum values as the position and direction of load cannot always be precisely defined.

Lubricating instructions: Lubricate only when shaft inserted, add lubricant through lube port until excess emerges.

The figures for dynamic load-carrying capacity have been calculated assuming a nominal travel of 100,000 m. For a nominal travel of 50,000 m, the 'C' figures in the table must be multiplied by a factor of 1.26.



STAR – Linear Sets incorporating one Torque-Resistant Linear Bushing

Linear Sets – steel, 1096-2..-

Type 1: one ball guide groove

Linear Sets – steel, 1096-5..-

Type 2: two ball guide grooves

Structural design

- Precision Housing (steel)
- Torque-Resistant Linear Bushing
- Precision Steel Shaft with ball guide groove
- Torque-transmitting steel load bearing plates adjusted to zero clearance before leaving the factory
- External seals
- Stability against cocking loads: see Linear Sets, Tandem version
- 1 or 2 ball guide grooves

Ordering data

Type 1: one ball guide groove



Shaft Ø d (mm)	Part numbers Linear Set with Torque-Resistant Linear Bushing and shaft					
	standard length as per table	shaft length 900 mm	shaft length 1200 mm	shaft length 2000 mm	shaft to specified length ¹⁾	customized shaft
12	1096-212-80	1096-212-85	1096-212-87	1096-212-88	1096-212-89	1096-212-86
16	1096-216-80	1096-216-85	1096-216-87	1096-216-88	1096-216-89	1096-216-86
20	1096-220-80	1096-220-85	1096-220-87	1096-220-88	1096-220-89	1096-220-86
25	1096-225-80	1096-225-85	1096-225-87	1096-225-88	1096-225-89	1096-225-86
30	1096-230-80	1096-230-85	1096-230-87	1096-230-88	1096-230-89	1096-230-86
40	1096-240-80	1096-240-85	1096-240-87	1096-240-88	1096-240-89	1096-240-86
50	1096-250-80	1096-250-85	1096-250-87	1096-250-88	1096-250-89	1096-250-86

Type 2: two ball guide grooves



Shaft Ø d (mm)	Part numbers Linear Set with Torque-Resistant Linear Bushing and shaft					
	standard length as per table	shaft length 900 mm	shaft length 1200 mm	shaft length 2000 mm	shaft to specified length ¹⁾	customized shaft
20	1096-520-80	1096-520-85	1096-520-87	1096-520-88	1096-520-89	1096-520-86
25	1096-525-80	1096-525-85	1096-525-87	1096-525-88	1096-525-89	1096-525-86
30	1096-530-80	1096-530-85	1096-530-87	1096-530-88	1096-530-89	1096-530-86
40	1096-540-80	1096-540-85	1096-540-87	1096-540-88	1096-540-89	1096-540-86
50	1096-550-80	1096-550-85	1096-550-87	1096-550-88	1096-550-89	1096-550-86

¹⁾ Also available with tubular shaft: 1096-...-69 or with corrosion-resistant steel shaft to DIN 17230 / EN 10088: 1096-...-79.

Dimensions

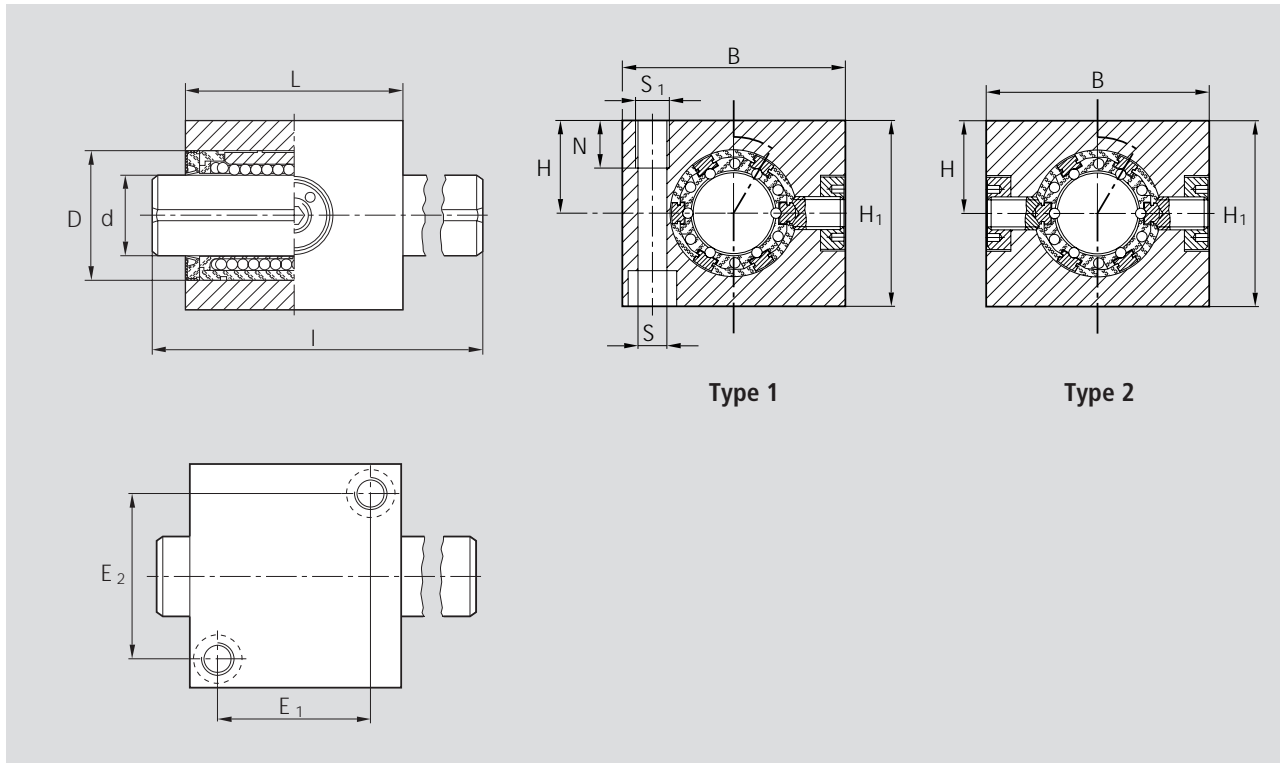

Ø d		Dimensions (mm)										Standard shaft l (mm)	Torque M _t		Load capacities ³⁾		Mass	
		Type 1	Type 2	B	H ₁	H ¹⁾ +0.013 -0.022	L	D	E ₁	E ₂	S ²⁾		S ₁	N	Type 1 (Nm)	Type 2 (Nm)	C (N)	stat. C ₀ (N)
12	-	42	35	18	40	22	28	30	5.3	M6	12	400	2	-	640	420	0.35	0.89
16	-	50	42	22	44	26	30	36	5.3	M6	12	400	3.3	-	780	530	0.55	1.57
20	20	60	50	25	55	32	39	44	6.4	M8	12	500	7.5	12	1550	1050	1.0	2.45
25	25	74	60	30	68	40	48	54	8.4	M10	15	500	15	24	3030	2180	1.5	3.80
30	30	84	70	35	80	47	58	62	10.5	M12	18	600	23	37	3680	2790	2.7	5.50
40	40	108	90	45	92	62	64	80	13.5	M16	20	600	53	86	6320	4350	5.0	9.80
50	50	130	105	50	114	75	84	100	13.5	M16	20	600	103	167	9250	6470	8.7	15.30

- 1) If two or more Linear Sets are mounted on the same shaft, they are leveled to the same dimension H by grinding after mounting. Dimension H is then 0.5 mm smaller.
- 2) Mounting screws to ISO 4762-8.8.
- 3) The load capacities stated are minimum values as the position and direction of load cannot always be precisely defined.

The figures for dynamic load-carrying capacity have been calculated assuming a nominal travel of 100,000 m. For a nominal travel of 50,000 m, the 'C' figures in the table must be multiplied by a factor of 1.26.



STAR – Linear Sets with Torque-Resistant Linear Bushings

Tandem version

Linear Sets – steel, 1097-2..-

Type 1: one ball guide groove

Linear Sets – steel, 1097-5..-

Type 2: two ball guide grooves

Structural design

- Precision Tandem Housing (steel)
- Two Torque-Resistant Linear Bushings
- Precision Steel Shaft with ball guide groove
- Torque-transmitting steel load bearing plates adjusted to zero clearance before leaving the factory
- External seals
- Stability against cocking loads
- 1 or 2 ball guide grooves

Ordering data

Type 1: one ball guide groove



Shaft Ø d (mm)	Part numbers Linear Set with Torque-Resistant Linear Bushing and shaft					
	standard length as per table	shaft length 900 mm	shaft length 1200 mm	shaft length 2000 mm	shaft to specified length ¹⁾	customized shaft
12	1097-212-80	1097-212-85	1097-212-87	1097-212-88	1097-212-89	1097-212-86
16	1097-216-80	1097-216-85	1097-216-87	1097-216-88	1097-216-89	1097-216-86
20	1097-220-80	1097-220-85	1097-220-87	1097-220-88	1096-220-89	1097-220-86
25	1097-225-80	1097-225-85	1097-225-87	1097-225-88	1097-225-89	1097-225-86
30	1097-230-80	1097-230-85	1097-230-87	1097-230-88	1097-230-89	1097-230-86
40	1097-240-80	1097-240-85	1097-240-87	1097-240-88	1097-240-89	1097-240-86
50	1097-250-80	1097-250-85	1097-250-87	1097-250-88	1097-250-89	1097-250-86

Type 2: two ball guide grooves



Shaft Ø d (mm)	Part numbers Linear Set with Torque-Resistant Linear Bushing and shaft					
	standard length as per table	shaft length 900 mm	shaft length 1200 mm	shaft length 2000 mm	shaft to specified length ¹⁾	customized shaft
20	1097-520-80	1097-520-85	1097-520-87	1097-520-88	1097-520-89	1097-520-86
25	1097-525-80	1097-525-85	1097-525-87	1097-525-88	1097-525-89	1097-525-86
30	1097-530-80	1097-530-85	1097-530-87	1097-530-88	1097-530-89	1097-530-86
40	1097-540-80	1097-540-85	1097-540-87	1097-540-88	1097-540-89	1097-540-86
50	1097-550-80	1097-550-85	1097-550-87	1097-550-88	1097-550-89	1097-550-86

¹⁾ Also available with tubular shaft: 1097-...-69 or
with corrosion-resistant steel shaft to DIN 17230 / EN 10088: 1097-...-79.

Dimensions

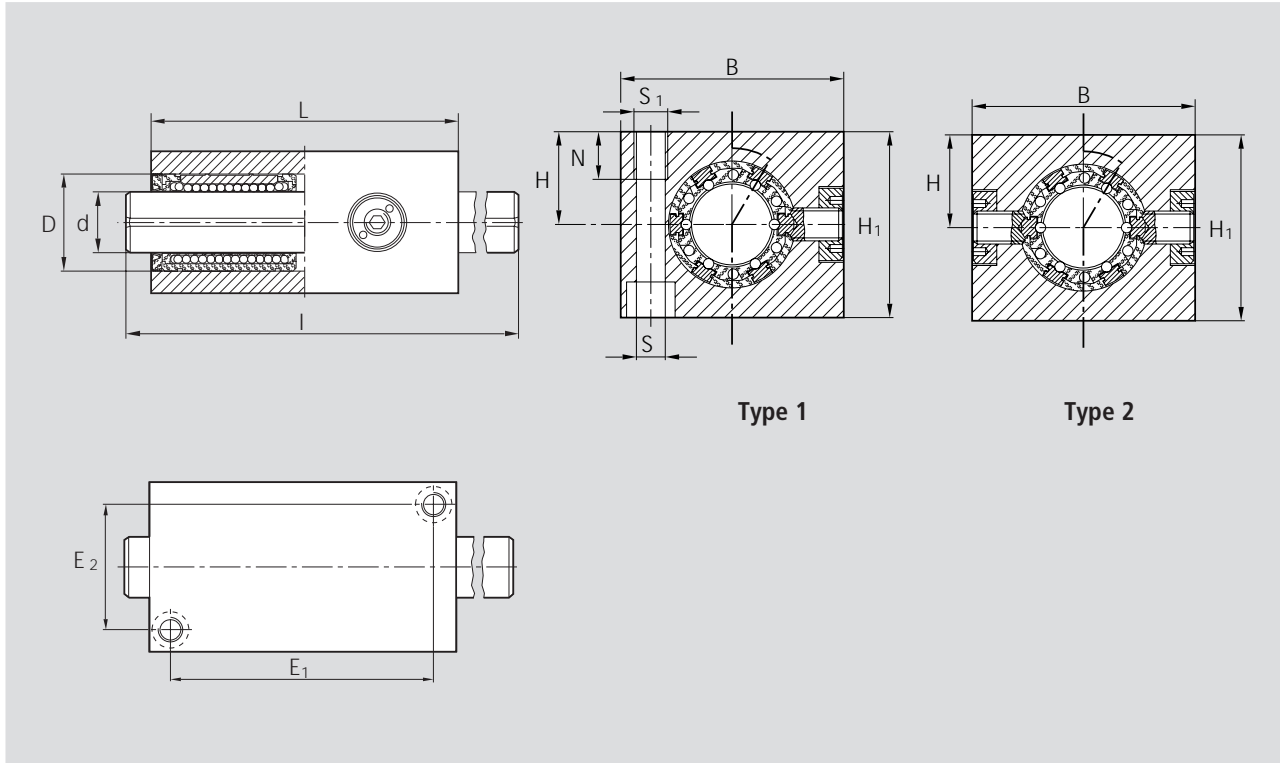

Ø d		Dimensions (mm)										Standard shaft l (mm)	Torque M_t		Load capacities ³⁾		Mass	
		Type 1	Type 2	B	H ₁	H ¹⁾ +0.013 -0.022	L	D	E ₁	E ₂	S ²⁾		S ₁	N	Type 1 (Nm)	Type 2 (Nm)	dyn. C (N)	stat. C ₀ (N)
12	-	42	35	18	76	22	64	30	5.3	M6	12	400	3.2	-	1040	840	0.7	0.89
16	-	50	42	22	84	26	70	36	5.3	M6	12	400	5.5	-	1260	1060	1.0	1.57
20	20	60	50	25	104	32	88	44	6.4	M8	12	500	12	20	2500	2100	1.9	2.45
25	25	74	60	30	130	40	110	54	8.4	M10	15	500	24	40	4900	4360	3.5	3.80
30	30	84	70	35	152	47	130	62	10.5	M12	18	600	37	60	6000	5580	5.2	5.50
40	40	108	90	45	176	62	148	80	13.5	M16	20	600	86	140	10200	8700	9.8	9.80
50	50	130	105	50	224	75	194	100	13.5	M16	20	600	167	272	15000	12940	17.0	15.30

¹⁾ If two or more Linear Sets are mounted on the same shaft, they are leveled to the same dimension H by grinding after mounting. Dimension H is then 0.5 mm smaller.

²⁾ Mounting screws to ISO 4762-8.8.

³⁾ Load capacity, when both linear bushings are subject to equal loading.

The load capacities stated are minimum values as the position and direction of load cannot always be precisely defined.

The figures for dynamic load-carrying capacity have been calculated assuming a nominal travel of 100,000 m. For a nominal travel of 50,000 m, the 'C' figures in the table must be multiplied by a factor of 1.26.

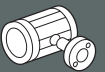

STAR – Linear Sets with Torque-Resistant Compact Linear Bushings

Sleeve Design

- Recommendations for mounting, arrangement of lubrication channels and bores as well as retention
- Recommended mounting bore: D^{H6} (D^{J6})

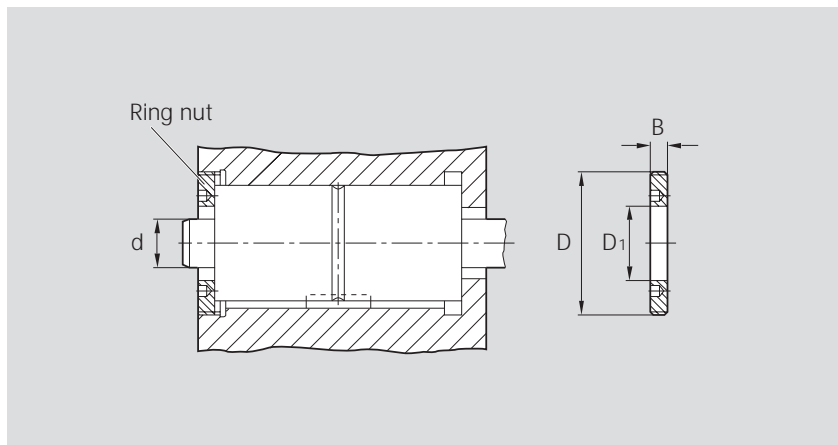
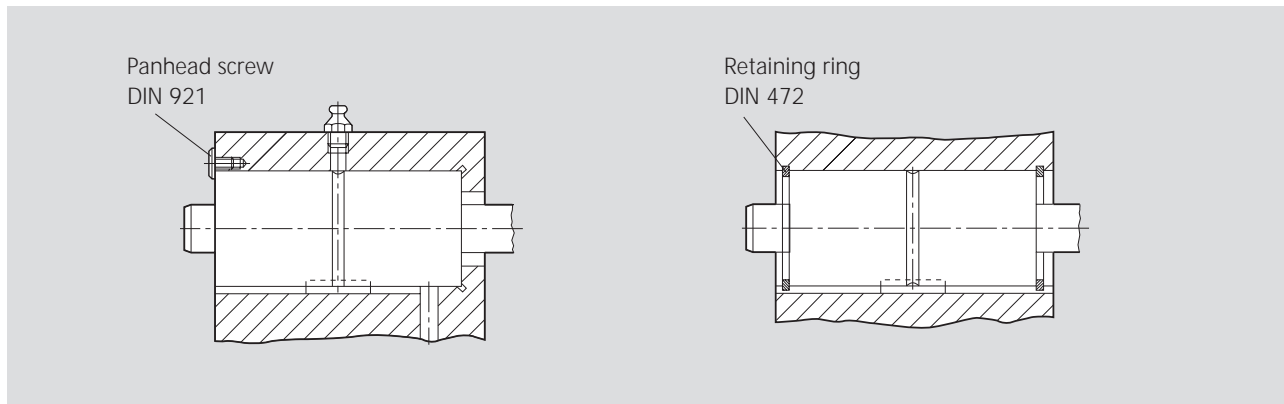

Shaft $\varnothing d$ (mm)	Ring nut			
	Part numbers	Dimensions (mm)		
		D	D_1	B
12	1507-1-4003	M40x1.5	22	8
16	1507-2-4004	M45x1.5	28	8
20	1507-3-4005	M55x1.5	34	10
25	1507-4-4006	M70x1.5	42	12
30	1507-5-4007	M78x2	52	15
40	1507-6-4009	M92x2	65	16
50	1507-7-4011	M112x2	82	18

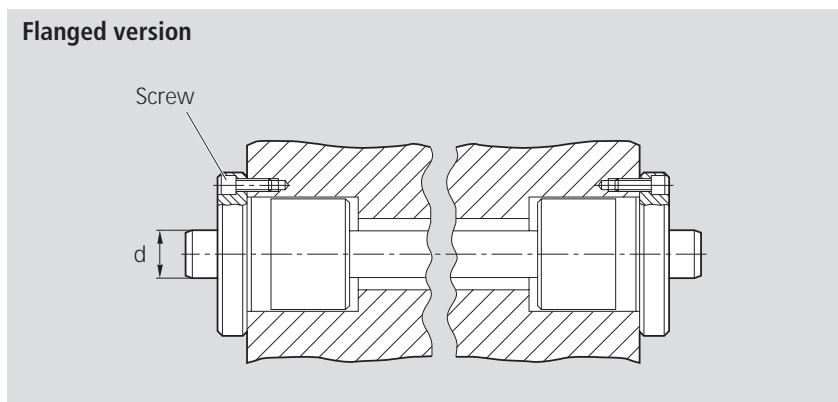

Shaft $\varnothing d$ (mm)	Screw
	ISO 4762-8.8
12	M4x16
16	M4x16
20	M5x16
25	M6x20
30	M8x25
40	M8x25
50	M10x30

Lubrication

- Lubrication for version with one Torque-Resistant Compact Linear Bushing
 - Lubricate only when shaft inserted. Add lubricant through lube port diam. 3.9 until excess emerges.
- Lubrication for Tandem version
 - Lubricate only when shaft inserted. Add lubricant through the centrally located lube groove on the outer diameter until excess emerges.
- Lubrication for Flanged version
 - Lubricate only when shaft inserted. Add lubricant through the recessed funnel-shaped lube port on the end face until excess emerges.

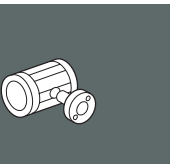

STAR – Linear Sets incorporating one Torque-Resistant Compact Linear Bushing

Linear Sets, 0721- Sleeve design

Structural design

- Space-saving steel sleeve
- Torque-Resistant Compact Linear Bushing
- Precision Steel Shaft with ball guide groove
- Lubricatable
- Torque-transmitting steel load bearing plates adjusted to zero clearance before leaving factory
- External seals
- Stability against cocking loads: see Linear Sets (sleeve design), Tandem version
- Keyway for torque transmission

One ball guide groove for shaft diameter d = 12 and 16 mm

Two ball guide grooves for shaft diameter d = 20 mm and over

Ordering data



Shaft Ø d (mm)	Part numbers					
	Linear Set with standard length as per table	Linear Set with Torque-Resistant Compact Linear Bushing and shaft				
		shaft length 900 mm	shaft length 1200 mm	shaft length 2000 mm	shaft to specified length ¹⁾	customized shaft
12	0721-212-80	0721-212-85	0721-212-87	0721-212-88	0721-212-89	0721-212-86
16	0721-216-80	0721-216-85	0721-216-87	0721-216-88	0721-216-89	0721-216-86
20	0721-520-80	0721-520-85	0721-520-87	0721-520-88	0721-520-89	0721-520-86
25	0721-525-80	0721-525-85	0721-525-87	0721-525-88	0721-525-89	0721-525-86
30	0721-530-80	0721-530-85	0721-530-87	0721-530-88	0721-530-89	0721-530-86
40	0721-540-80	0721-540-85	0721-540-87	0721-540-88	0721-540-89	0721-540-86
50	0721-550-80	0721-550-85	0721-550-87	0721-550-88	0721-550-89	0721-550-86

¹⁾ Also available with tubular shaft: 0721-...-69 or with corrosion-resistant steel shaft to DIN 17230 / EN 10088: 0721-...-79.

The figures for dynamic load-carrying capacity have been calculated assuming a nominal travel of 100,000 m. For a nominal travel of 50,000 m, the 'C' figures in the table must be multiplied by a factor of 1.26.

Dimensions

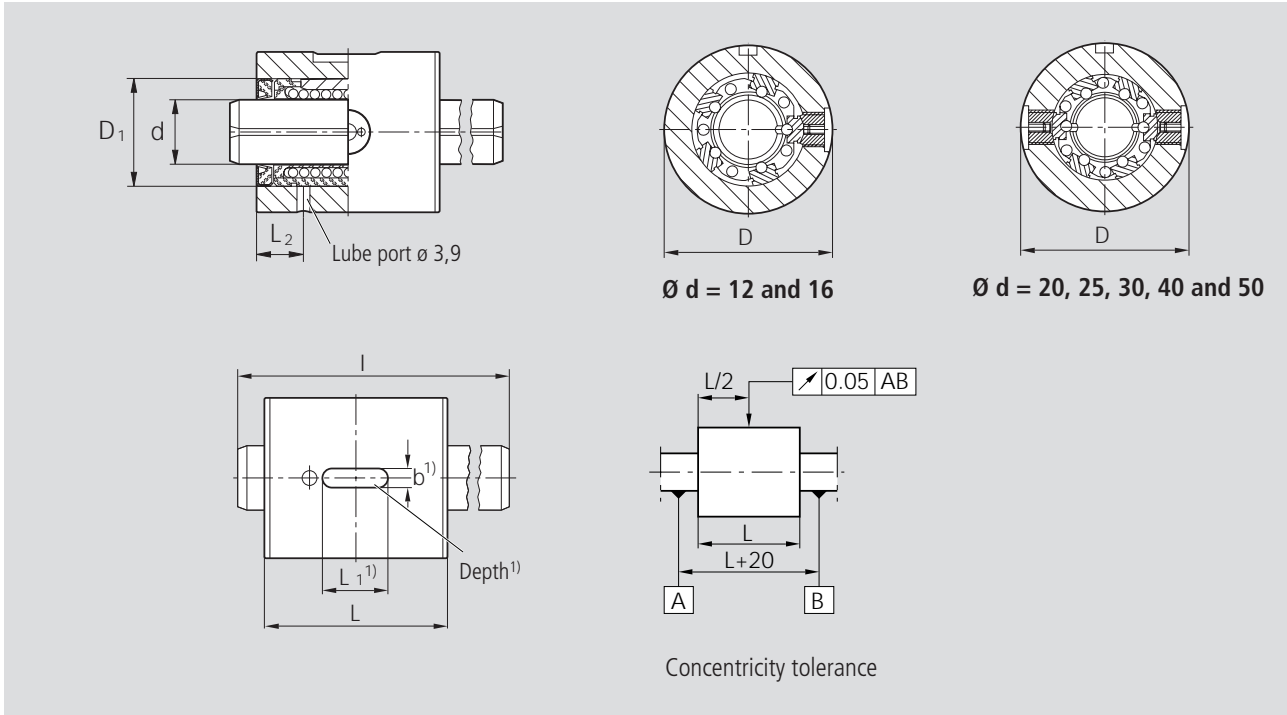

¹⁾ For Key A... DIN 6885

$\varnothing d$	Dimensions (mm)							Standard shaft l (mm)	Torque M_t (Nm)	Load capacities ²⁾		Mass	
	D h6	L h11	D_1	L_1	b p9	t	L_2			dyn. C (N)	stat. C_0 (N)	without shaft (kg)	shaft (kg/m)
12	32	40	22	14	5	3	11	400	2	640	420	0.16	0.89
16	36	44	26	16	5	3	12	400	3.3	780	530	0.20	1.57
20	48	55	32	20	5	3	14	500	12	1550	1050	0.50	2.45
25	56	68	40	25	6	3.5	15.5	500	24	3030	2180	0.80	3.80
30	65	80	47	28	6	3.5	16.5	600	37	3680	2790	1.20	5.50
40	80	92	62	32	8	4	18.5	600	86	6320	4350	1.80	9.80
50	100	114	75	40	8	4	22.5	600	167	9250	6470	3.70	15.30

²⁾ The load capacities stated are minimum values as the position and direction of load cannot always be precisely defined.

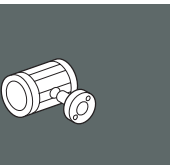

STAR – Linear Sets with Torque-Resistant Compact Linear Bushings Tandem version

Linear Sets, 0722- Sleeve design

Structural design

- Space-saving steel sleeve
- Two Torque-Resistant Compact Linear Bushings
- Precision Steel Shaft with ball guide groove
- Torque-transmitting steel load bearing plates adjusted to zero clearance before leaving factory
- External seals
- Stability against cocking loads
- Keyway for torque transmission
- Lubricatable

**One ball guide groove for
shaft diameter d = 12 and 16 mm**

**Two ball guide grooves for
shaft diameter d = 20 mm and over**

Ordering data



Shaft Ø d (mm)	Part numbers					
	Linear Set with Torque-Resistant Compact Linear Bushing and shaft					
	standard length as per table	shaft length 900 mm	shaft length 1200 mm	shaft length 2000 mm	shaft to specified length ¹⁾	customized shaft
12	0722-212-80	0722-212-85	0722-212-87	0722-212-88	0722-212-89	0722-212-86
16	0722-216-80	0722-216-85	0722-216-87	0722-216-88	0722-216-89	0722-216-86
20	0722-520-80	0722-520-85	0722-520-87	0722-520-88	0722-520-89	0722-520-86
25	0722-525-80	0722-525-85	0722-525-87	0722-525-88	0722-525-89	0722-525-86
30	0722-530-80	0722-530-85	0722-530-87	0722-530-88	0722-530-89	0722-530-86
40	0722-540-80	0722-540-85	0722-540-87	0722-540-88	0722-540-89	0722-540-86
50	0722-550-80	0722-550-85	0722-550-87	0722-550-88	0722-550-89	0722-550-86

¹⁾ Also available with tubular shaft: 0722-...-69 or
with corrosion-resistant steel shaft to DIN 17230 / EN 10088: 0722-...-79.

The figures for dynamic load-carrying capacity have been calculated assuming a nominal travel of 100,000 m.
For a nominal travel of 50,000 m, the 'C' figures in the table must be multiplied by a factor of 1.26.

Dimensions

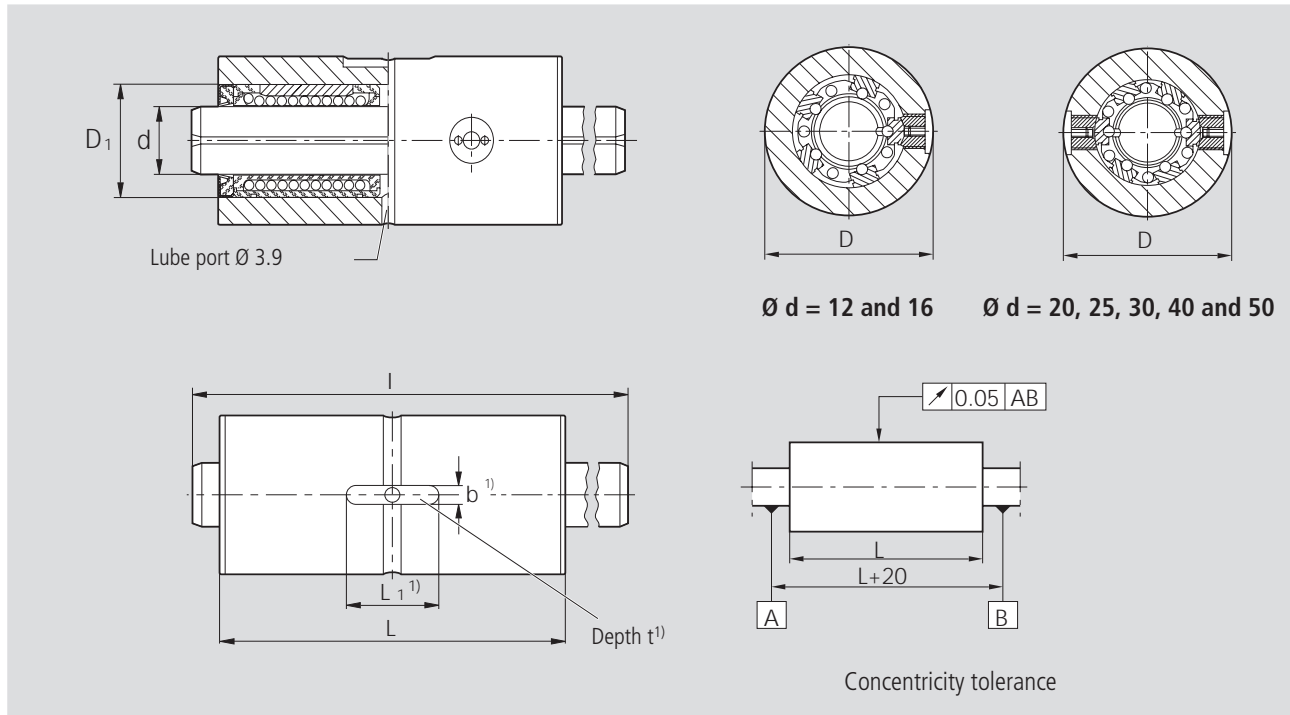

¹⁾ For Key A... DIN 6885

$\varnothing d$	Dimensions (mm)						Standard shaft l (mm)	Torque M_t (Nm)	Load capacities ²⁾		Mass	
	D h6	L h11	D_1	L_1	b p9	t			dyn. C (N)	stat. C_0 (N)	without shaft (kg)	shaft (kg/m)
12	32	76	22	20	5	3	400	3.2	1040	840	0.32	0.89
16	36	84	26	22	5	3	400	5.5	1260	1060	0.40	1.57
20	48	104	32	28	5	3	500	20	2500	2100	0.95	2.45
25	56	130	40	36	6	3.5	500	40	4900	4360	1.50	3.80
30	65	152	47	40	6	3.5	600	60	6000	5580	2.30	5.50
40	80	176	62	45	8	4	600	140	10200	8700	3.50	9.80
50	100	224	75	63	8	4	600	272	15000	12940	7.30	15.30

²⁾ Load capacity, when both linear bushings are subject to equal loading.
The load capacities stated are minimum values as the position and direction of load cannot always be precisely defined.

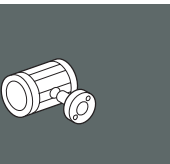

STAR – Linear Sets incorporating one Torque-Resistant Compact Linear Bushing

Linear Sets, 0723- Sleeve design, flanged version

Structural design

- Flanged steel sleeve
- Torque-Resistant Compact Linear Bushing
- Precision Steel Shaft with ball guide groove
- Torque-transmitting steel load bearing plates adjusted to zero clearance before leaving factory
- External seals
- Stability against cocking loads: installation of two Linear Sets (see also "Retention options - Linear Sets (sleeve design)")
- Lubricatable

One ball guide groove for shaft diameter d = 12 and 16 mm

Two ball guide grooves for shaft diameter d = 20 mm and over

Ordering data



Shaft Ø d (mm)	Part numbers Linear Set with Torque-Resistant Compact Linear Bushing and shaft					
	standard length as per table	shaft length 900 mm	shaft length 1200 mm	shaft length 2000 mm	shaft to specified length ¹⁾	customized shaft
12	0723-212-80	0723-212-85	0723-212-87	0723-212-88	0723-212-89	0723-212-86
16	0723-216-80	0723-216-85	0723-216-87	0723-216-88	0723-216-89	0723-216-86
20	0723-520-80	0723-520-85	0723-520-87	0723-520-88	0723-520-89	0723-520-86
25	0723-525-80	0723-525-85	0723-525-87	0723-525-88	0723-525-89	0723-525-86
30	0723-530-80	0723-530-85	0723-530-87	0723-530-88	0723-530-89	0723-530-86
40	0723-540-80	0723-540-85	0723-540-87	0723-540-88	0723-540-89	0723-540-86
50	0723-550-80	0723-550-85	0723-550-87	0723-550-88	0723-550-89	0723-550-86

¹⁾ Also available with tubular shaft: 0723-...-69 or with corrosion-resistant steel shaft to DIN 17230 / EN 10088: 0723-...-79.

The figures for dynamic load-carrying capacity have been calculated assuming a nominal travel of 100,000 m. For a nominal travel of 50,000 m, the 'C' figures in the table must be multiplied by a factor of 1.26.

Dimensions

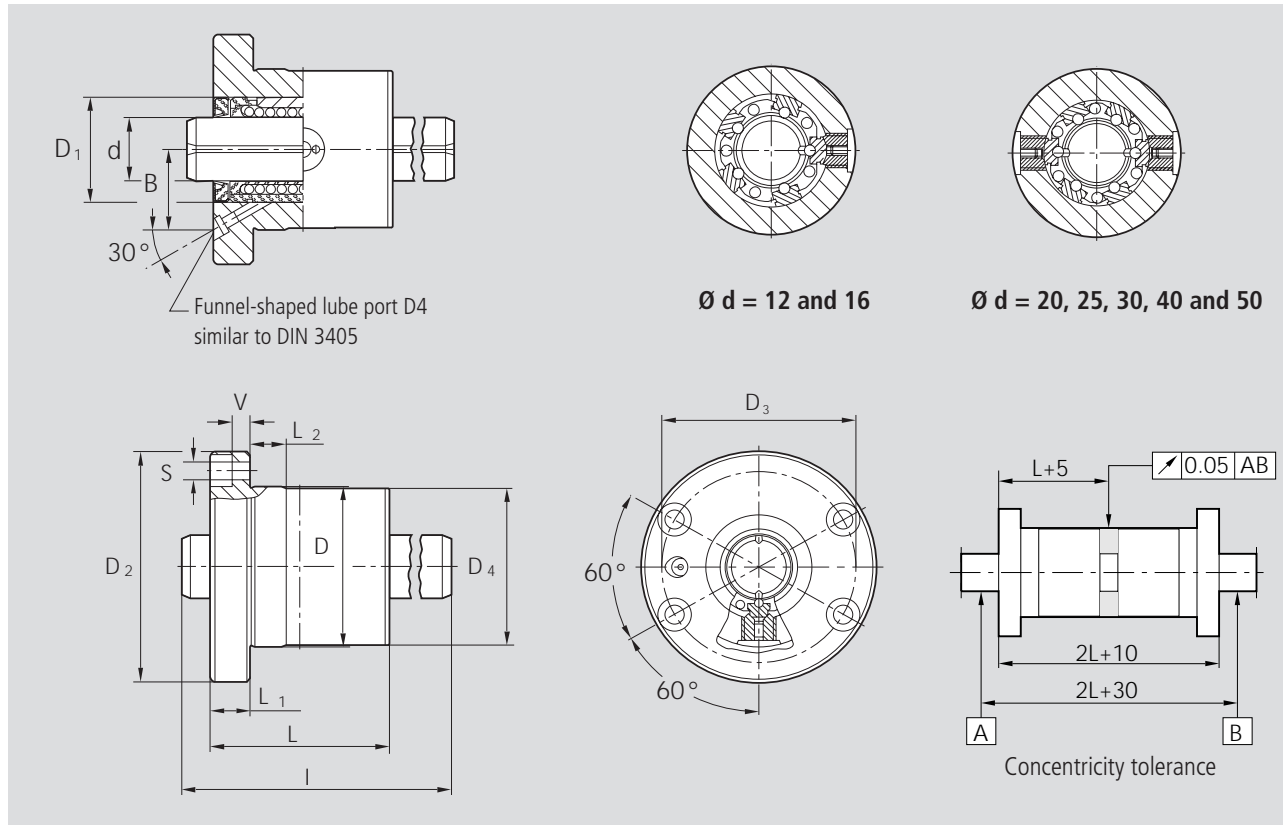

Ød	Dimensions (mm)											Standard shaft I (mm)	Torque M_t (Nm)	Load capacities ²⁾		Mass	
	D h6	D ₄ -0.1 -0.3	D ₁	D ₂	L h11	L ₁ -0.2	L ₂	D ₃	S ¹⁾	V	B			dyn. C (N)	stat. C ₀ (N)	without shaft (kg)	shaft (kg/m)
12	32	32	22	50	40	10	10	40	4.5	4.5	17.4	400	2	640	420	0.25	0.89
16	36	36	26	54	44	10	10	44	4.5	4.5	20	400	3.3	780	530	0.30	1.57
20	48	48	32	70	55	12	10	58	5.5	5	24	500	12	1550	1050	0.70	2.45
25	56	56	40	82	68	14	10	68	6.6	5.5	29	500	24	3030	2180	1.10	3.80
30	65	65	47	98	80	18	10	80	9	7	33	600	37	3680	2790	1.75	5.50
40	80	80	62	114	92	18	16	95	9	7	41.7	600	86	6320	4350	2.50	9.80
50	100	100	75	140	114	22	16	118	11	8.5	50.5	600	167	9250	6470	4.85	15.30

¹⁾ Mounting screws to ISO 4762-8.8.

²⁾ The load capacities stated are minimum values as the position and direction of load cannot always be precisely defined.

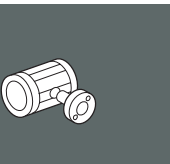

STAR – Linear Bushings for Combined Linear and Rotary Motion

Linear Bushings for Combined Linear and Rotary Motion, 0663- with deep groove ball bearings, series 618

Linear Bushings for Combined Linear and Rotary Motion, 0664- with deep groove ball bearings, series 60

Structural Design

- Maintenance-free and sealed with shields (series 60)

Sizes 12 to 40

- Segmental Linear Bushing
- Steel sleeve
- External wiper seals
- Pressed-on deep groove ball bearings

Sizes 5, 8, 50, 60 and 80

- Standard Linear Bushing
- Internal wiper seals
- Pressed-on deep groove ball bearings

Ordering data

with series 618 deep groove ball bearings (sizes 12 to 40)



(Sizes 5, 8, 50, 60 and 80)



with series 60 deep groove ball bearings



Shaft Ø d (mm)	Part numbers with series 618 deep groove ball bearings	Mass (kg)
5	0663-205-00	0.02
8	0663-208-00	0.06
12	0663-212-00	0.08
16	0663-216-00	0.11
20	0663-220-00	0.15
25	0663-225-00	0.17
30	0663-230-00	0.35
40	0663-240-00	0.49
50	0663-250-00	1.29
60	0663-260-00	2.39
80	0663-280-00	5.35

Shaft Ø d (mm)	Part numbers with series 60 deep groove ball bearings	Mass (kg)
5	0664-205-00	0.03
8	0664-208-00	0.11
12	0664-212-00	0.14
16	0664-216-00	0.20
20	0664-220-00	0.27
25	0664-225-00	0.32
30	0664-230-00	0.56
40	0664-240-00	0.87
50	0664-250-00	1.78
60	0664-260-00	3.26

Dimensions

with series 618 deep groove ball bearings

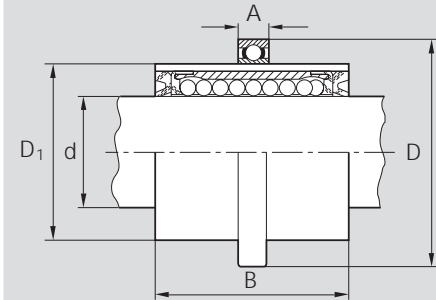

Ø d	Dimensions (mm)				Load capacities ³⁾ (N)	
	D	D ₁	A	B	dyn. C	stat. C ₀
5	21	12 ¹⁾	5	22	180	140
8 ²⁾	32	20	7	25	320	240
12	37	25	7	30	480	420
16	42	30	7	34	720	620
20	47	35	7	38	1020	870
25	52	40	7	45	1630	1360
30	65	50	7	54	2390	1960
40	78	60	10	66	3870	3270
50	95	75 ¹⁾	10	100	8260	6470
60	115	90 ¹⁾	13	125	11500	9160
80	150	120 ¹⁾	16	165	21000	16300

with series 60 deep groove ball bearings

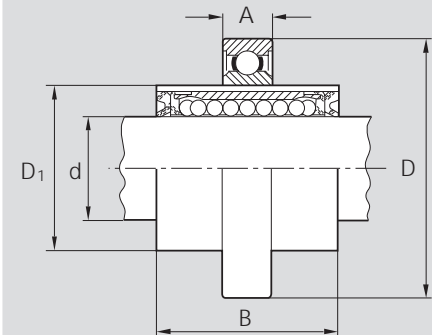

Ø d	Dimensions (mm)				Load capacities ³⁾ (N)	
	D	D ₁	A	B	dyn. C	stat. C ₀
5	28	12 ¹⁾	8	22	180	140
8 ²⁾	42	20	12	25	320	240
12	47	25	12	30	480	420
16	55	30	13	34	720	620
20	62	35	14	38	1020	870
25	68	40	15	45	1630	1360
30	80	50	16	54	2390	1960
40	95	60	18	66	3870	3270
50	115	75 ¹⁾	20	100	8260	6470
60	140	90 ¹⁾	24	125	11500	9160

The figures for dynamic load-carrying capacity have been calculated assuming a nominal travel of 100,000 m. For a nominal travel of 50,000 m, the 'C' figures in the tables opposite must be multiplied by a factor of 1.26.

¹⁾ Oversize

²⁾ A spacer sleeve is located between the ball bearing and the Standard Linear Bushing.

³⁾ The figures given for load capacity are minimum values as the position and load direction cannot be precisely defined.

Sealing:

The linear bushings are sealed at both ends.

Series 0663:

If the deep groove ball bearings are to be sealed with shaft seals, please send for Table 06/060-00.

Series 0664:

In all sizes the deep groove ball bearings are maintenance-free with shields at both ends.

Recommended tolerances

Series 0663 und 0664:

Shaft: d_{h6}
Housing bore D^{K6} or D^{K7}

Other tolerance zones may be selected for special purposes (refer to the anti-friction bearing manufacturer's mounting recommendations).



STAR – Linear Bushings for Combined Linear and Rotary Motion

Linear Bushings for Combined Linear and Rotary Motion, 0665-
with needle roller bearings, without wiper seal

Linear Bushings for Combined Linear and Rotary Motion, 0667-
with needle roller bearings, with wiper seal

Structural Design

- Standard Linear Bushing (closed type)
- Needle roller bearings
- Steel spacer rings
- Retaining rings

Ordering data



Shaft Ø d (mm)	Part numbers		Mass (kg)
	with two seals	without seals	
5	0667-005-00	0665-005-00	0.02
8	0667-008-00	0665-008-00	0.04
12	0667-012-00	0665-012-00	0.08
16	0667-016-00	0665-016-00	0.10
20	0667-020-00	0665-020-00	0.20
25	0667-025-00	0665-025-00	0.34
30	0667-030-00	0665-030-00	0.56
40	0667-040-00	0665-040-00	1.39
50	0667-050-00	0665-050-00	2.18
60	0667-060-00	0665-060-00	4.14
80	0667-080-00	0665-080-00	7.11

The figures for dynamic load-carrying capacity have been calculated assuming a nominal travel of 100,000 m. For a nominal travel of 50,000 m, the 'C' figures in the tables must be multiplied by a factor of 1.26.

Dimensions

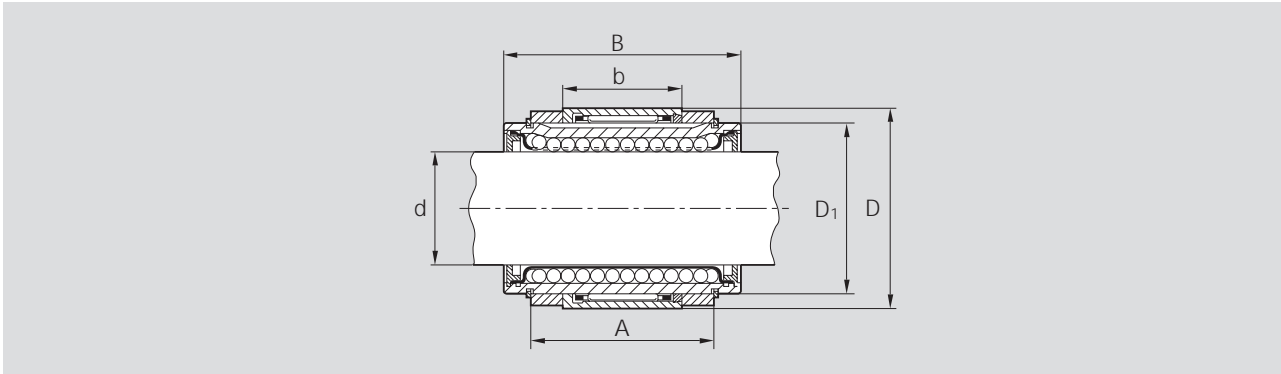

Ø d	Dimensions (mm)					Load capacities ⁴⁾ (N)	
	D ₁	B	D	b	A	dyn. C	stat. C ₀
5 ¹⁾	12	22	19	12	12	180	140
8 ¹⁾	16	25	24	13	14.1	320	240
12	22	32	30	16	20	420	280
16	26	36	34	20	22.1	580	440
20	32	45	42	20	28	1170	860
25	40	58	50	30	40	2080	1560
30	47	68	57	30	48	2820	2230
40 ²⁾	62.1 ³⁾	80	80	56	56	5170	3810
50 ²⁾	75	100	92	70	73.1	8260	6470
60 ²⁾	90	125	110	70	95	11500	9160
80 ²⁾	120	165	140	81.6	125	21000	16300

¹⁾ With plastic ball retainer.

²⁾ Contrary to the illustration, these sizes have two needle roller bearings.

³⁾ The basic body is a special version of the closed Standard Linear Bushing.

⁴⁾ The figures given for load capacity are minimum values as the position and load direction cannot be precisely defined.

Recommended tolerances:

Shaft d_{h6}

Housing bore D^{K6} or D^{K7}

Other tolerance zones may be selected for special purposes

(refer to the anti-friction bearing manufacturer's mounting recommendations).



STAR – Precision Steel Shafts

STAR Precision Steel Shafts come in various tolerance grades, as solid or tubular shafts, in heat-treatable or corrosion-resistant steel, with hard chrome plating or STAR-Resist coating, and in metric or inch sizes.

They are induction hardened and centerless ground.

Besides their use as guide shafts for linear bushings, STAR Precision Steel Shafts have proven successful in numerous other applications, for example as rollers, pistons or axles.

We supply STAR Precision Steel Shafts to your requirements: cut to length and chamfered at both ends, machined to your drawing or description, or in unmachined mill-cut lengths.

For shipment, STAR Precision Steel Shafts are coated with an anti-corrosion film and packed in wooden crates, cardboard boxes, railroad containers, etc., according to the size and quantity involved.

You can rely on competent advice and rapid service from the headquarters and regional sales offices in Germany as well as subsidiaries and agencies in over 60 countries all around the world.

STAR Precision Steel Shafts offer you the right solution for any requirement.





STAR – Precision Steel Shafts

Overview

Metric sizes

Shaft Ø d (mm)	Part numbers Solid shafts					
	Heat-treatable steel		X46Cr13		X90CrMoV18	
	h6	h7	h6	h7	h6	h7
5	1000-005-00	1000-005-01	1000-005-30	1000-005-31		
6	1000-006-00	1000-006-01	1000-006-30	1000-006-31		
8	1000-008-00	1000-008-01	1000-008-30	1000-008-31		
10	1000-010-00	1000-010-01	1000-010-30	1000-010-31		
12	1000-012-00	1000-012-01	1000-012-30	1000-012-31	1000-012-20	1000-012-21
14	1000-014-00	1000-014-01				
15	1000-015-00	1000-015-01				
16	1000-016-00	1000-016-01	1000-016-30	1000-016-31	1000-016-20	1000-016-21
18	1000-018-00	1000-018-01				
19	1000-019-00	1000-019-01				
20	1000-020-00	1000-020-01	1000-020-30	1000-020-31	1000-020-20	1000-020-21
22	1000-022-00	1000-022-01				
24	1000-024-00	1000-024-01				
25	1000-025-00	1000-025-01	1000-025-30	1000-025-31	1000-025-20	1000-025-21
30	1000-030-00	1000-030-01	1000-030-30	1000-030-31	1000-030-20	1000-030-21
32	1000-032-00	1000-032-01				
35	1000-035-00	1000-035-01				
38	1000-038-00	1000-038-01				
40	1000-040-00	1000-040-01	1000-040-30	1000-040-31	1000-040-20	1000-040-21
45	1000-045-00	1000-045-01				
50	1000-050-00	1000-050-01	1000-050-30	1000-050-31	1000-050-20	1000-050-21
55	1000-055-00	1000-055-01				
60	1000-060-00	1000-060-01	1000-060-30	1000-060-31	1000-060-20	1000-060-21
70	1000-070-00	1000-070-01				
80	1000-080-00	1000-080-01	1000-080-30	1000-080-31	1000-080-20	1000-080-21
100	1000-100-00	1000-100-01				
110	1000-110-00	1000-110-01				

Inch sizes

Shaft Ø d (inch)	Part numbers Solid shafts					
	Heat-treatable steel				X90CrMoV18	
	Class "L"	Class "S"			Class "L"	Class "S"
1/4"	1000-804-08	1000-804-09				
3/8"	1000-806-08	1000-806-09				
1/2"	1000-808-08	1000-808-09			1000-808-28	1000-808-29
5/8"	1000-810-08	1000-810-09				
3/4"	1000-812-08	1000-812-09			1000-812-28	1000-812-29
1"	1000-816-08	1000-816-09			1000-816-28	1000-816-29
1 1/4"	1000-820-08	1000-820-09				
1 1/2"	1000-824-08	1000-824-09			1000-824-28	1000-824-29
2"	1000-832-08	1000-832-09				

Shaft Ø d (mm)	Part numbers					
	Star Resist h6	Solid shaft		Tubular shaft		hard chrome plated h7
		hard chrome plated		heat-treatable steel		
		h6	h7	h6	h7	
5	1000-005-70					
6						
8	1000-008-70					
10	1000-010-70					
12	1000-012-70	1000-012-60	1000-012-61			
14						
15						
16	1000-016-70	1000-016-60	1000-016-61			
18						
19						
20	1000-020-70	1000-020-60	1000-020-61			
22						
24						
25	1000-025-70	1000-025-60	1000-025-61	1001-025-10	1001-025-11	1001-025-41
30	1000-030-70	1000-030-60	1000-030-61	1001-030-10	1001-030-11	1001-030-41
32						
35						
38						
40	1000-040-70	1000-040-60	1000-040-61	1001-040-10	1001-040-11	1001-040-41
45						
50	1000-050-70	1000-050-60	1000-050-61	1001-050-10	1001-050-11	1001-050-41
55						
60		1000-060-60	1000-060-61	1001-060-10	1001-060-11	1001-060-41
70						
80		1000-080-60	1000-080-61	1001-080-10	1001-080-11	1001-080-41
100				1001-100-10	1001-100-11	
110						



STAR – Precision Steel Shafts

Technical Data

Dimensional accuracy and tolerance zones

The diameters of Precision Steel Shafts are accurate to within the tolerance zones h6 and h7. Details on the dimensional accuracy of the shafts are compiled in the tables on the right. The tolerance for the diameter of soft-annealed shaft sections may go slightly beyond the tolerance zones quoted.

On request, Precision Steel Shafts may also be supplied in tolerance zone h5 (standard diameters 30 to 80 only).

For special diameter tolerances, please consult us.

Straightness

Because of the length of the shafts, it would be uneconomical to use the straightness measurement method specified in DIN ISO 1101 section 14.1. Instead of direct measurement for straightness, the shafts are tested for runout tolerance as described in DIN ISO 1101 section 14.13.1. See "Measurement of straightness".

Tolerances for metric-size steel shafts

Nominal diameter (mm)	over up to	3	6	10	18	30	50	80
		6	10	18	30	50	80	120
Tolerance for diameter	h6	(μm)	0	0	0	0	0	0
	h7	(μm)	-8	-9	-11	-13	-16	-19
Roundness	h6	(μm)	0	0	0	0	0	0
	h7	(μm)	-12	-15	-18	-21	-25	-30
Taper, Convexity, Concavity	h6	(μm)	4	4	5	6	7	8
	h7	(μm)	5	6	8	9	11	13
Straightness	h6	(μm)	5	6	8	9	11	13
	h7	(μm)	8	9	11	13	16	19
Straightness	($\mu\text{m}/\text{m}$)	75	60	50	50	50	50	50
Measured value $t_1^{1)}$	($\mu\text{m}/\text{m}$)	150	120	100	100	100	100	100
Surface roughness C.L.A.(R_a) ²⁾	(μm)	0.32	0.32	0.32	0.32	0.32	0.32	0.32

¹⁾ Dial gauge reading during straightness measurement. For lengths of less than 1 m the lowest possible value is 40 μm . This corresponds to a straightness tolerance of 20 μm .

²⁾ Applies to shafts made of heat-treatable or anti-friction bearing steel only. Please contact us for surface finish and surface roughness (R_a) tolerances for hard chrome plated and corrosion-resistant steel shafts.

Tolerances for inch-size steel shafts

Shaft \varnothing d		Class "L"		Class "S" ³⁾	
(Inch)	(mm)	(Inch)	(mm)	(Inch)	(mm)
$1/4$	6.35	-0.0005 -0.0010	-0.013 -0.025	-0.0010 -0.0015	-0.025 -0.038
$3/8$	9.525	-0.0005 -0.0010	-0.013 -0.025	-0.0010 -0.0015	-0.025 -0.038
$1/2$	12.70	-0.0005 -0.0010	-0.013 -0.025	-0.0010 -0.0015	-0.025 -0.038
$5/8$	15.875	-0.0005 -0.0010	-0.013 -0.025	-0.0010 -0.0015	-0.025 -0.038
$3/4$	19.05	-0.0005 -0.0010	-0.013 -0.025	-0.0010 -0.0015	-0.025 -0.038
1	25.40	-0.0005 -0.0010	-0.013 -0.025	-0.0010 -0.0015	-0.025 -0.038
$1 1/4$	31.75	-0.0005 -0.0010	-0.013 -0.025	-0.0010 -0.0015	-0.025 -0.038
$1 1/2$	38.1	-0.0006 -0.0011	-0.015 -0.028	-0.0011 -0.0016	-0.028 -0.041
2	50.8	-0.0006 -0.0013	-0.015 -0.033	-0.0013 -0.0020	-0.033 -0.051

³⁾ Class "S" by special request only.

Measurement of straightness

Measurements are performed at points equidistant between the support points and the overhanging ends of the shaft. The measured values are then halved and the resulting value t_1 gives the straightness.

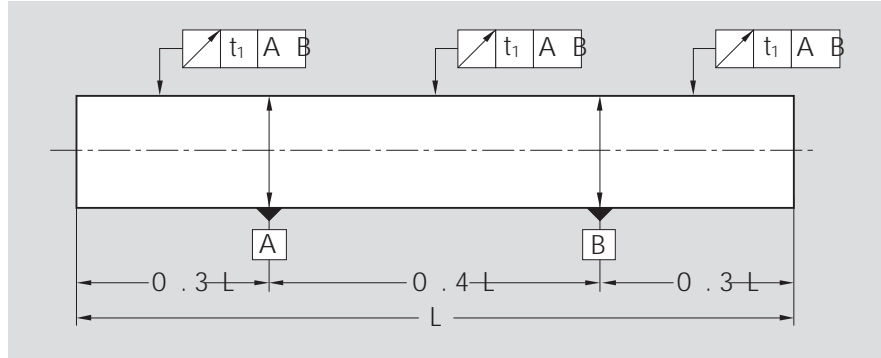

Measurement of roundness

The figure shows the roundness of a raw shaft compared with that of a finished Precision Steel Shaft.

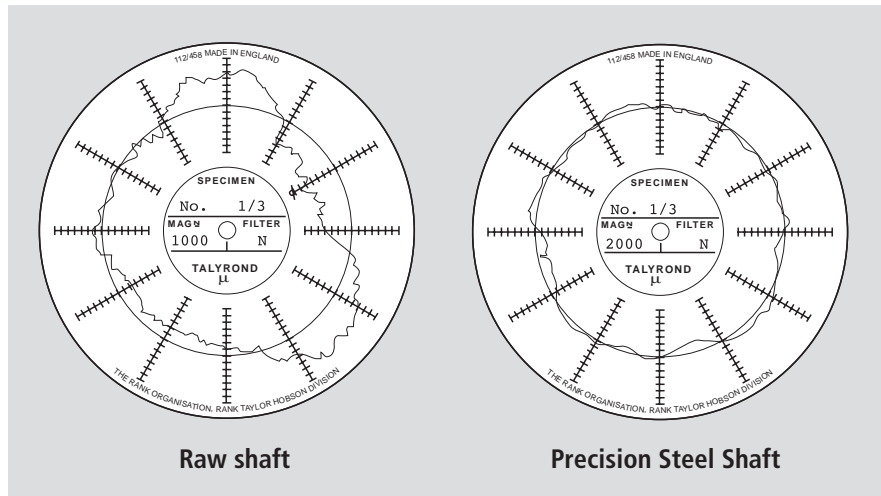

Shaft hardness

The surface of the shaft is induction-hardened to a depth of at least 0.4 up to 3.2 mm, depending on the shaft diameter. Surface hardness and depth of hardness are extremely uniform, both in the axial and in the circumferential direction. This is the reason for the excellent dimensional consistency and the long service life of Precision Steel Shafts.

The photographs opposite show a longitudinal and a transverse section through a hardened and ground Precision Steel Shaft. The hardened surface zone has been made visible by caustic etching.

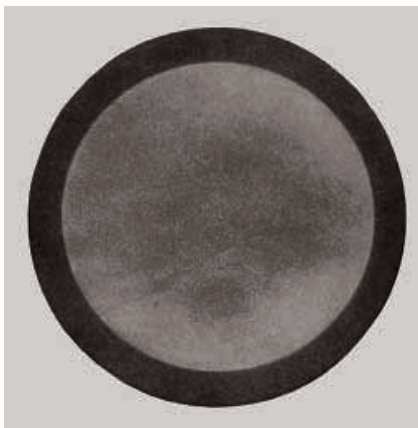

Shaft \varnothing d	(mm)	over up to	3	10	18	30	50	80
Depth of hardness ¹⁾	(mm)	min.	0.4	0.6	0.9	1.5	2.2	3.2

¹⁾ Please contact us to obtain the depth of hardness for corrosion-resistant steel shafts.

STAR – Precision Steel Shafts

Technical Data

Minimum hardness

Solid and tubular shafts → HRC 60

Corrosion-resistant steel shafts → HRC 53 to DIN 17230 / EN 10088

The figure opposite shows the micro-structure in the surface zone of a shaft cross section (magnification approx. 10x). The hardened outer layer of martensite and the smooth transition to the tough inner core structure are clearly visible.



Induction-hardened surface zone
Structure: martensite
hardness ≥ HRC 60 (Rockwell C)

Transitional structure:
martensite
troostite
pearlite

Core structure:
pearlite and ferrite

Shaft deflection

When steel shafts are used as linear motion guideways for linear bushings it is important that the shaft deflection occurring under load is kept within certain limits, as otherwise the proper functioning and the service life of the assembly could be impaired¹⁾.

To facilitate the determination of shaft deflection by calculation, we have compiled the most common load cases together with the associated deflection equations in the table below.

The equations for calculation of the inclination of the shaft in the linear bushing (tan α) can also be taken from this table.

Case No.	Loading conditions	Deflection equation	Shaft inclination in linear bushings
1		$f_1 = \frac{F \cdot a^3}{6 \cdot E \cdot J} \cdot \left(2 - \frac{3 \cdot a}{l}\right)$ $f_{m1} = \frac{F \cdot a^2}{24 \cdot E \cdot J} \cdot (3l - 4a)$	$\tan \alpha_{(x=a)} = \frac{F \cdot a^2 \cdot b}{2 \cdot E \cdot J \cdot l}$
2		$f_2 = \frac{F \cdot l^3}{2 \cdot E \cdot J} \cdot \frac{a^2}{l^2} \cdot \left(1 - \frac{4}{3} \cdot \frac{a}{l}\right)$ $f_{m2} = \frac{F \cdot l^3}{8 \cdot E \cdot J} \cdot \frac{a}{l} \cdot \left(1 - \frac{4}{3} \cdot \frac{a^2}{l^2}\right)$	$\tan \alpha_{(x=a)} = \frac{F \cdot a \cdot b}{2 \cdot E \cdot J}$
3		$f_3 = \frac{F \cdot l^3}{3 \cdot E \cdot J} \cdot \frac{a^3 \cdot b^3}{l^3 \cdot l^3}$ $f_{m3} = \frac{2 \cdot F \cdot l^3}{3 \cdot E \cdot J} \cdot \frac{a^3}{l^3} \cdot \frac{b^2}{l^2} \cdot \left(\frac{l}{l+2a}\right)^2$	$\tan \alpha_{(x=b)} = \frac{F \cdot a^2 \cdot b^2}{2 \cdot E \cdot J \cdot l^2} \cdot \left(1 - \frac{2 \cdot b}{l}\right)$
4		$f_4 = \frac{F \cdot l^3}{3 \cdot E \cdot J} \cdot \frac{a^2 \cdot b^2}{l^2 \cdot l^2}$ $f_{m4} = f_4 \cdot \frac{l+b}{3 \cdot b} \cdot \sqrt{\frac{l+b}{3 \cdot a}}$	$\tan \alpha_{(x=b)} = \frac{F \cdot a}{6 \cdot E \cdot J \cdot l} \cdot (3b^2 - l^2 + a^2)$
5		$f_5 = \frac{5 \cdot F \cdot l^3}{384 \cdot E \cdot J}$	$\tan \alpha_{(x=0)} = \frac{F \cdot l^2}{24 \cdot E \cdot J}$

¹⁾ There will be no loss of load-carrying capacity or service life in Super Linear Bushings and provided the shaft deflection does not exceed 30' (tan 30' = 0.0087).

The table gives the values for the maximum permissible shaft inclination ($\tan \alpha_{\max}$) for each size of Standard Linear Bushing.

At $\tan \alpha = \tan \alpha_{\max}$ the permissible static load capacity is approx. $0.4 C_0$.

Shaft		Shaft	
$\varnothing d$ (mm)	$\tan \alpha_{\max}$	$\varnothing d$ (mm)	$\tan \alpha_{\max}$
5	$12.3 \cdot 10^{-4}$	30	$6.4 \cdot 10^{-4}$
8	$10.0 \cdot 10^{-4}$	40	$7.3 \cdot 10^{-4}$
12	$10.1 \cdot 10^{-4}$	50	$6.3 \cdot 10^{-4}$
16	$8.5 \cdot 10^{-4}$	60	$5.7 \cdot 10^{-4}$
20	$8.5 \cdot 10^{-4}$	80	$5.7 \cdot 10^{-4}$
25	$7.2 \cdot 10^{-4}$		

Values for E x J and mass for steel shafts

Solid shafts						
$\varnothing d$ (mm)	E x J (N x mm ²)	Mass (kg/m)	$\varnothing d$		E x J (N x mm ²)	Mass (kg/m)
			(Inches)	(mm)		
5	$6.44 \cdot 10^6$	0.15	1/4	6.35	$1.68 \cdot 10^7$	0.25
8	$4.22 \cdot 10^7$	0.39	3/8	9.525	$8.48 \cdot 10^7$	0.56
10	$1.03 \cdot 10^8$	0.61	1/2	12.7	$2.68 \cdot 10^8$	0.99
12	$2.14 \cdot 10^8$	0.88	5/8	15.875	$6.55 \cdot 10^8$	1.54
16	$6.76 \cdot 10^8$	1.57	3/4	19.05	$1.36 \cdot 10^9$	2.22
20	$1.65 \cdot 10^9$	2.45	1	25.4	$4.29 \cdot 10^9$	3.95
25	$4.03 \cdot 10^9$	3.83	1 1/4	31.75	$1.05 \cdot 10^{10}$	6.18
30	$8.35 \cdot 10^9$	5.51	1 1/2	38.1	$2.17 \cdot 10^{10}$	8.89
40	$2.64 \cdot 10^{10}$	9.80	2	50.8	$6.87 \cdot 10^{10}$	15.81
50	$6.44 \cdot 10^{10}$	15.32				
60	$1.34 \cdot 10^{11}$	22.05				
80	$4.22 \cdot 10^{11}$	39.21				

Tubular shafts			
$\varnothing d$		E x J (N x mm ²)	Mass (kg/m)
outer \varnothing (mm)	inner \varnothing (mm)		
25	14	$3.63 \cdot 10^9$	2.63
30	19	$7.01 \cdot 10^9$	3.30
40	26.5	$2.13 \cdot 10^{10}$	5.50
50	29.6	$5.65 \cdot 10^{10}$	9.95
60	36.5	$1.15 \cdot 10^{11}$	13.89
80	57.4	$3.10 \cdot 10^{11}$	19.02

STAR – Precision Steel Shafts

Diameters and Lengths

Mill-cut lengths

Longer shafts than those quoted can also be supplied on request. These shafts are made up of shaft sections of precisely measured length joined end-to-end (see section on "Composite shafts" below).

Type of shaft	Diameter (mm)	Mill-cut length ¹⁾ (m)
Solid shafts ²⁾	< 20 (except 12 and 16) 12, 16 and ≥ 20	3.5 up to 4.0 5.7 up to 5.9
Tubular shafts	25 up to 100	4 up to 5.9 ³⁾
Corrosion-resistant steel shafts	5 up to 20 > 20 up to 80	3.5 up to 4.0 5.7 up to 5.9

- 1) The first 50 mm at each end of mill-cut lengths may deviate slightly from the nominal diameter.
- 2) Solid shafts of lengths up to 8 m and diameter 20 and over are available on request.
- 3) Depending on size.

Composite shafts

Plug-and-socket joints

We can supply composite shafts for applications requiring a shaft longer than the mill-cut lengths available. The shaft sections are joined together by a spigot-and-recess arrangement, one section having a locating plug and the other a mating hole (see figure below). The joined shaft must rest on a full-length, continuous support rail or must at least be supported at regular intervals with one of the supports located at the joint between the shaft sections (see "Shaft Support Rails").

The shafts must be axially tensioned against each other at the time the shaft assembly is screwed to the shaft support rail. This is to prevent a gap opening at the joint when the shaft assembly is loaded in service.

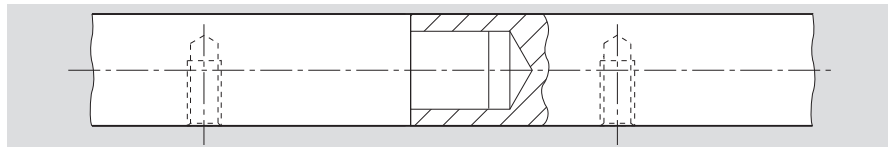

Shafts with threaded joints (does not apply to corrosion-resistant steel shafts)

At the customer's request, the plug can be threaded and the mating hole tapped (see figure below). Line-up markings are then provided at the ends of the mating shaft sections to facilitate vertical alignment of the radial holes for attachment of the coupled shaft assembly to the shaft support rail.

All machining and marking operations are carried out on the shaft sections after they have been hardened and ground. Since it will not be possible to re-grind the finished joint, extreme care is taken in the machining of the centering arrangement to ensure precision mating of the shaft sections.

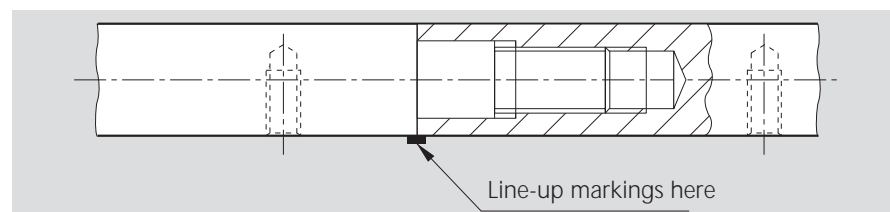

Shaft Machining

Steel shafts intended for use as linear motion guideways for Linear Bushings must be chamfered at the ends to prevent damage to the ball retainers or wipers when the linear bushing is being pushed onto the shaft.

The figure and the table give the dimensions of the chamfers required. Linear bushings with seals must not be pushed over sharp edges in the shaft (e.g. retaining ring grooves), as this would damage the seal lips.

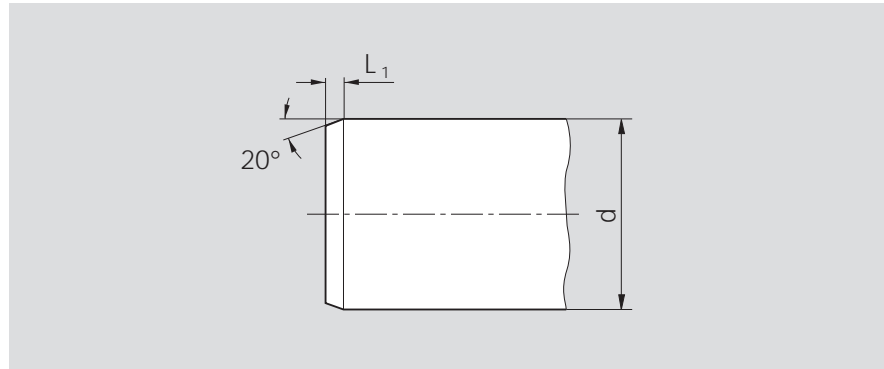

Shaft	Ø d (mm)	5	8	10	12	16	20	25	30	40	50	60	80
Length of chamfer	L ₁ (mm)	1.5	1.5	1.5	2	2	2	2	2	3	3	3	3

Hardened and ground steel shafts in mill-cut lengths are always in stock. These can be cut to any desired length and machined to give them any of the following:

- reduced-diameter ends
- male or female threads
- countersinks
- radial or axial holes
- recesses
- or other specially-machined features.

Length tolerances for cut-to-size shafts

Dimensions in mm	
Length	Tolerance
up to 400	±0.5
over 400 up to 1000	±0.8
over 1000 up to 2000	±1.2
over 2000 up to 4000	±2.0
over 4000 up to 6000	±3.0
over 6000 up to 8000	±3.5

Steel shafts with closer length tolerances can also be supplied against a surcharge.



STAR – Precision Steel Shafts

Shaft Machining

Standard shaft ends

Machining of shaft ends has been standardized at STAR.

The expertise acquired over the years in special shaft machining techniques offers you the following benefits:

- **rapid processing,**
- **lower costs.**

If you would like your shafts machined to any of the examples given below, we recommend that you

- copy the drawing,
- enter the dimensions and tolerances, and
- indicate whether you would like only one or both shaft ends to be so machined.

When selecting tolerances, please avoid any overdetermination.

Attach the annotated drawing to your order.

Shaft ends with retaining ring groove to DIN 471

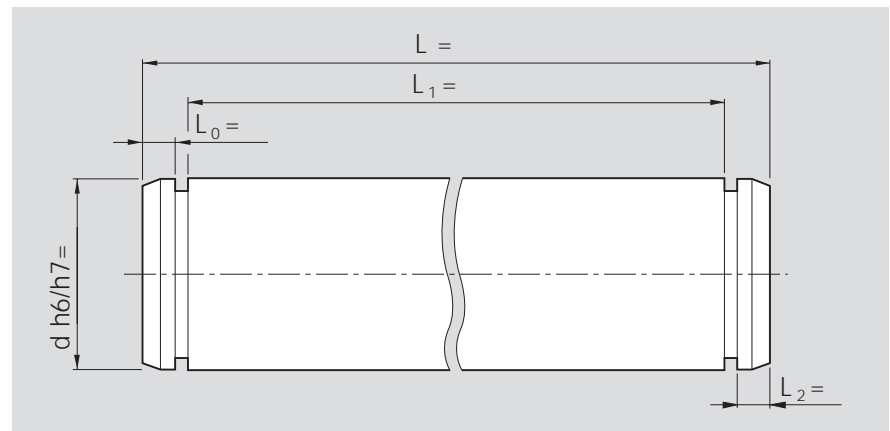

Shaft ends with 90° cutout

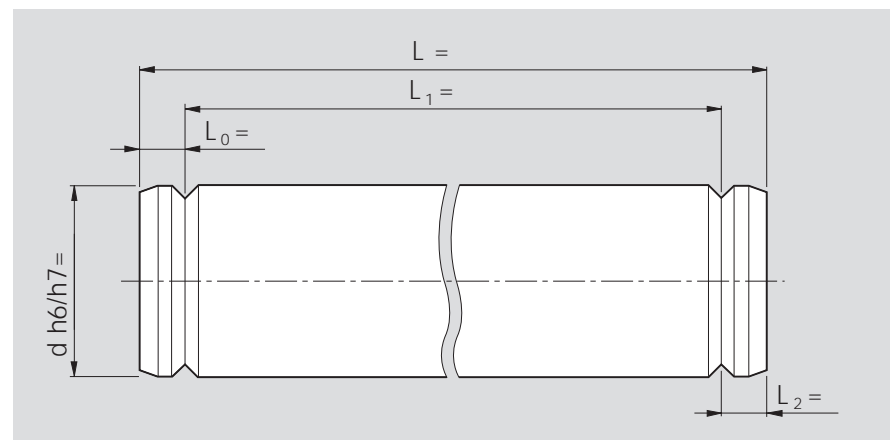

Shaft ends with 90° countersink

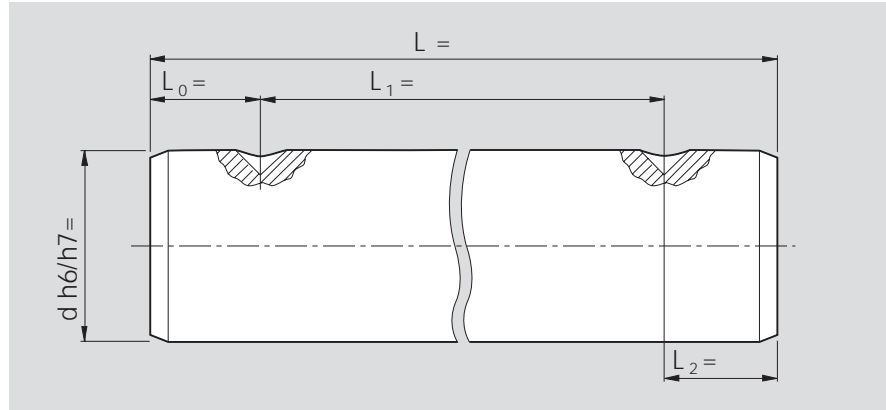

Shaft ends with single flat (both ends)

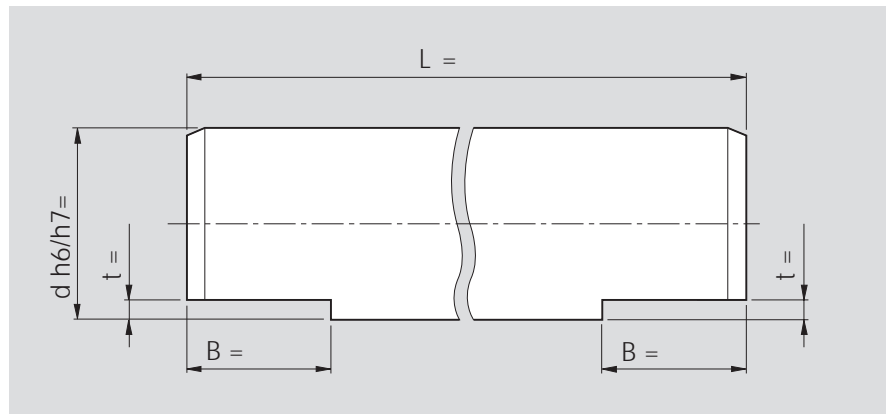

Shaft ends with outer flats (one end)

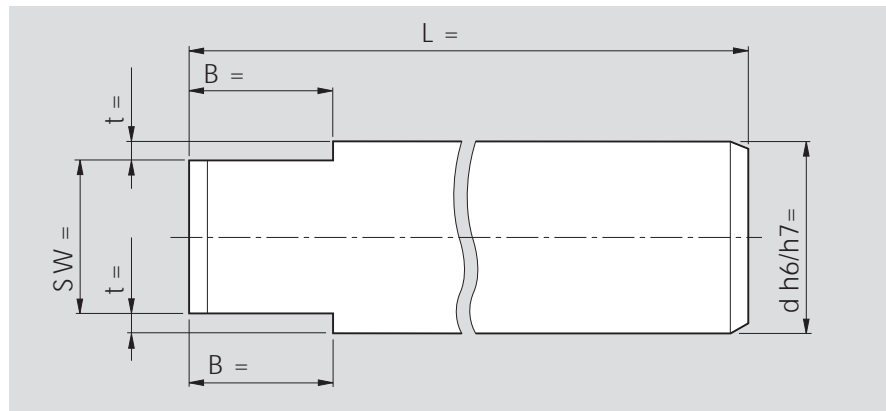

STAR – Precision Steel Shafts

Shaft Machining

Shaft ends with grooves (both ends)

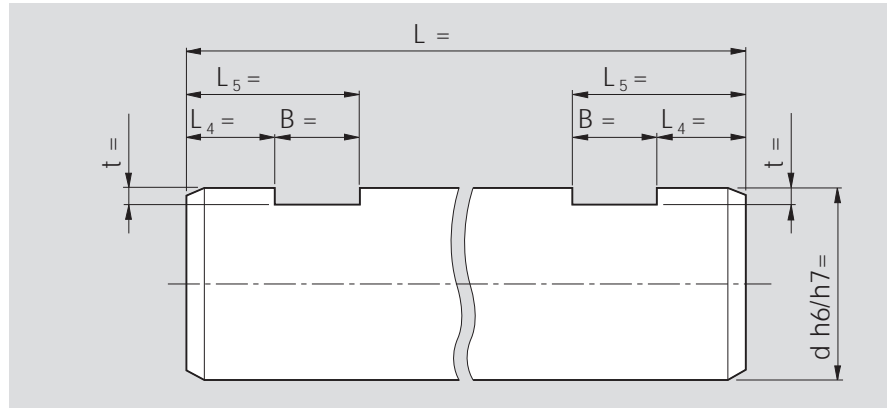

Shaft ends with inner flats (one end)

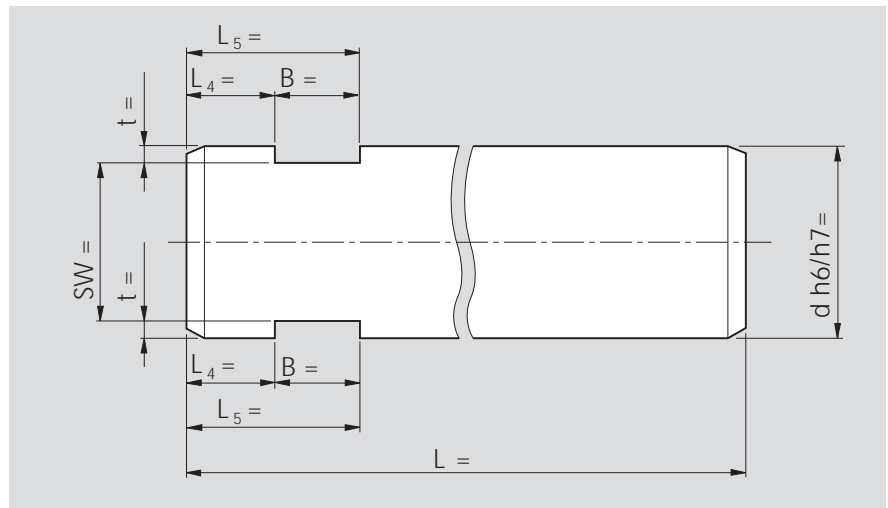

Shaft ends with holes tapped to pitch circle (both ends)

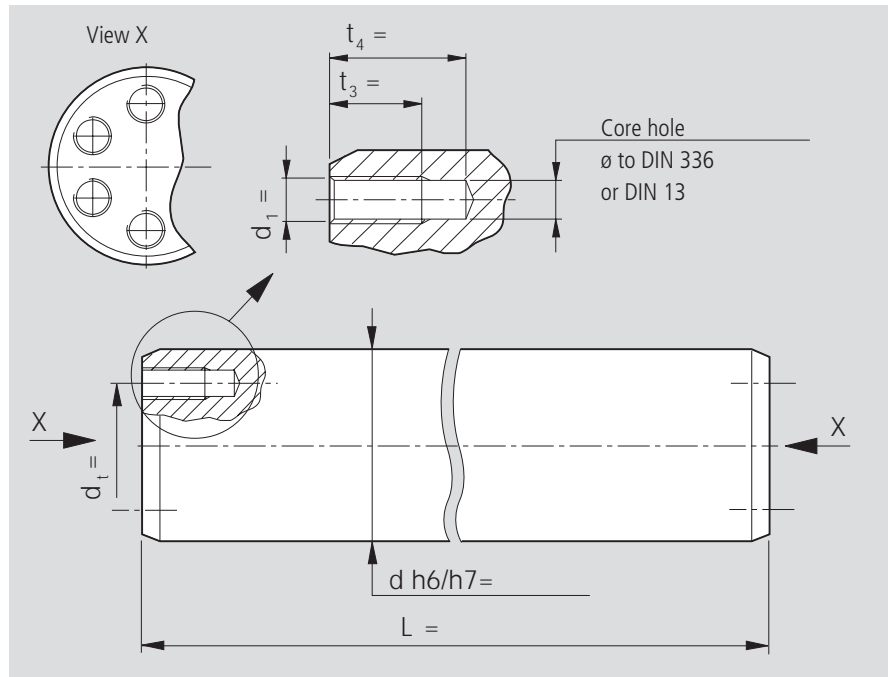

Shaft ends with spigot (both ends)

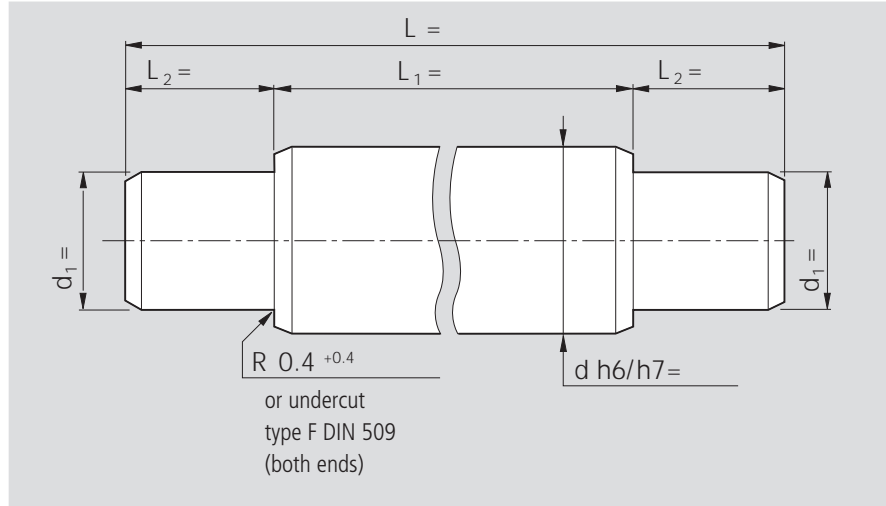

Shaft ends with threaded spigot (both ends)

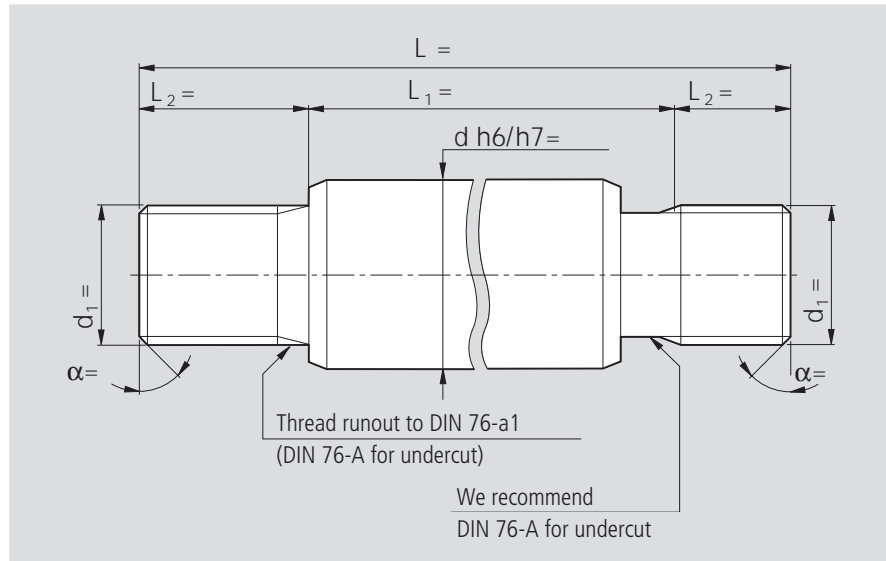

Shaft ends with spigot and threaded spigot (both ends)

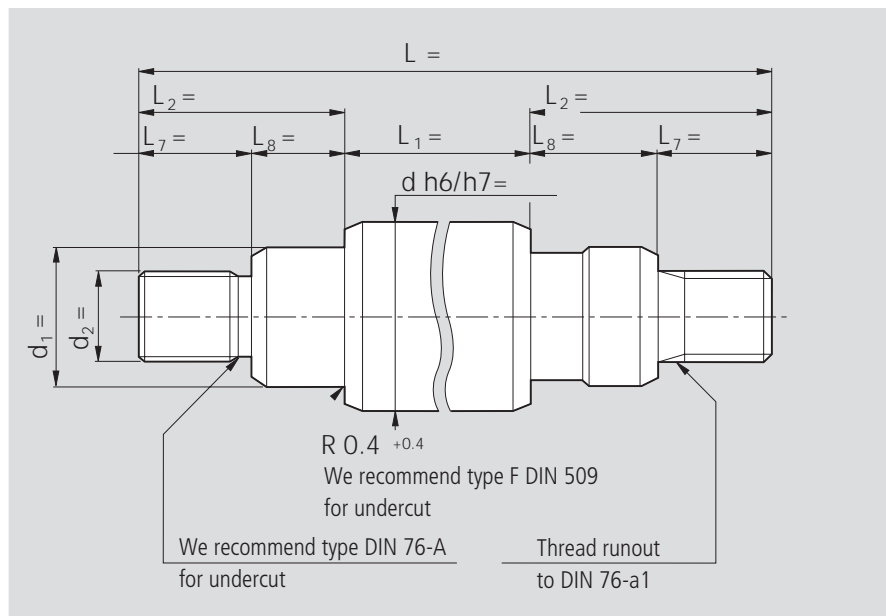

STAR – Precision Steel Shafts

Shaft Machining

Shaft ends with tapped hole and centering bore to DIN 332-D

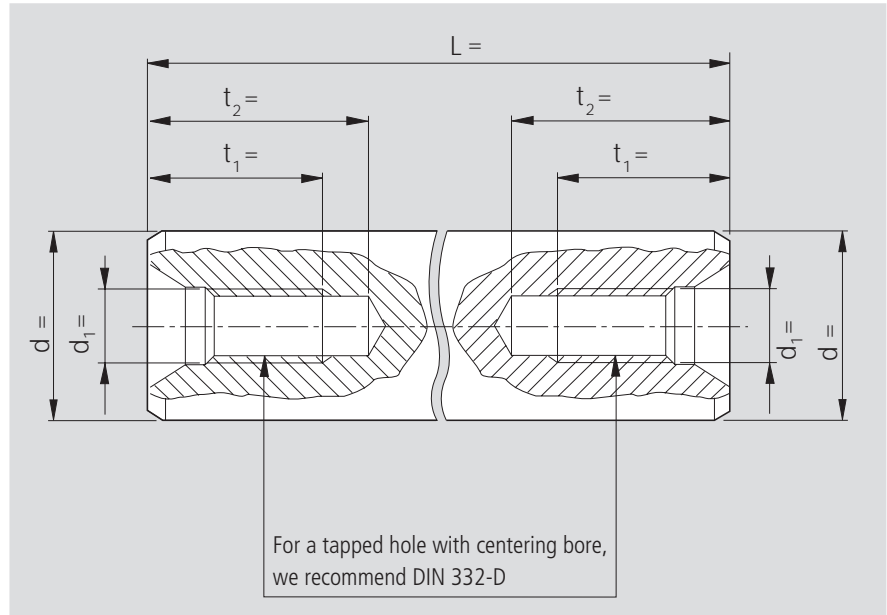

Shaft ends with tapped hole

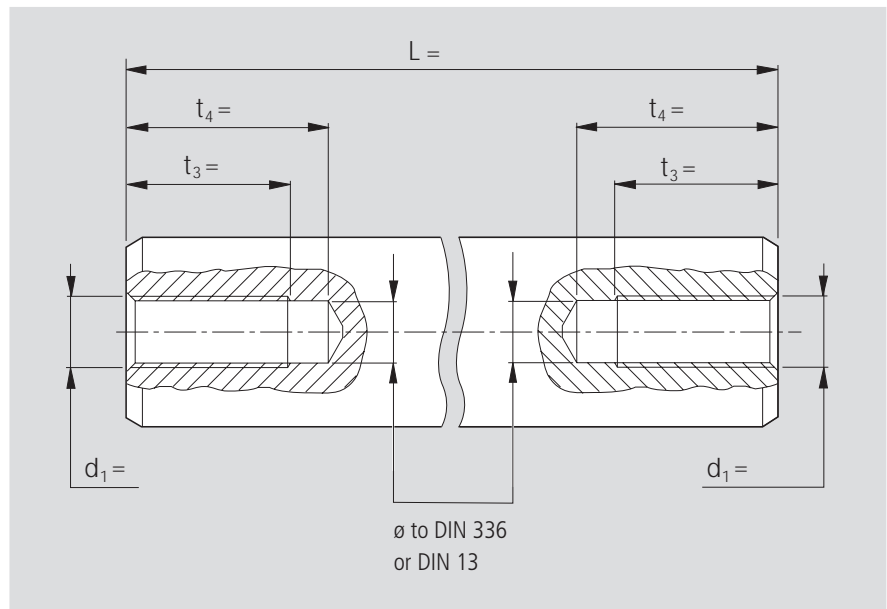

Shafts with radial holes, drilled or drilled and tapped

Shafts that have to be supported require radial holes for attachment of the shaft supports. The radial holes are drilled into the steel shafts after hardening and grinding.

The diameter, depth and spacing of the holes depend on the diameter of the shaft. Refer to the table in the sections "Shaft Support Rails for Standard and Super Linear Bushings" and "Shaft Support Rails for Radial Linear Bushings" for standard dimensions.

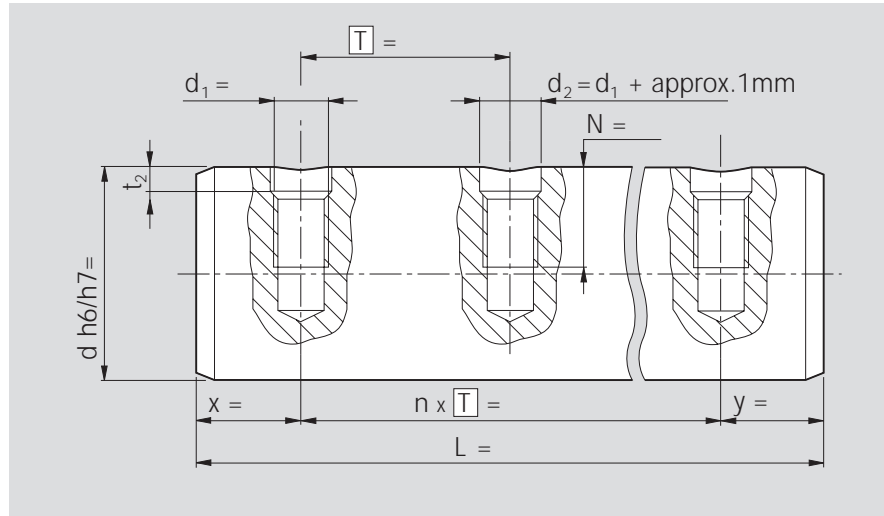

Recommended values for boring of clearing holes in the hardened surface zone

Shaft Ø d (mm)	Dimensions (mm)		Shaft Ø d (mm)	Dimensions (mm)	
	d ₁	t ₂		d ₁	t ₂
12	M4	2.5	50	M12	4.0
16	M5	2.5	50	M14	4.5
20	M6	3.0	50	M16	5.0
25	M8	3.0	60	M14	5.5
30	M10	3.5	60	M20	6.5
40	M10	4.0	80	M16	5.5
40	M12	4.5	80	M24	6.5

Values for corrosion-resistant steel shafts on request

For matching Shaft Support Rails, see the related chapter.

Steel Shafts can also be delivered with ready-mounted Shaft Support Rails as standard.

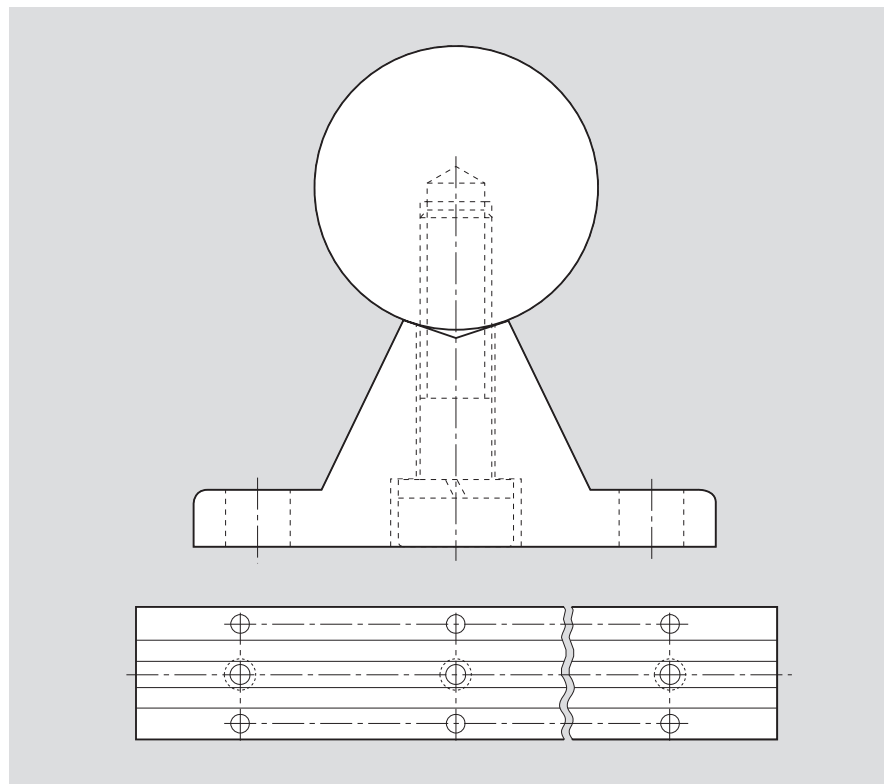

STAR – Precision Steel Shafts

Ordering Data

Solid shafts made of heat-treatable steel, metric sizes

When a shaft forms an integral part of an anti-friction bearing system, the materials used have to satisfy exacting requirements.

STAR offers the optimum shaft material for each diameter range. The materials we use have a much higher carbon content compared to frequently used mass-produced steels, which has a very positive influence on the achievable surface hardness and provides better resistance to aging.

The exceptionally uniform surface hardness and hardening depth of STAR shafts, combined with an excellent degree of purity, homogeneous microstructure and defined grain sizes, ensure particularly long service life under rolling loads.

Available diameters (mm)

5, 6, 8, 10, 12, 14, 15, 16, 18, 20, 22, 24, 25, 30, 32, 35, 38, 40, 45, 50, 55, 60, 70, 80, 100, 110

Ø d (mm)	Lengths (m)
5-10, 14, 15, 18	approx. 3.5 to 4.0
12, 16, 20-110	approx. 5.7 to 5.9

Solid shafts from 20 mm in diameter and up to 8 m in length on request.

Greater overall lengths are composed of sections joined end-to-end.

STAR Linear Bushings can roll over joints without any problems.

Materials	Hardness
Cf 53, Cf 60, Ck 67	min. 60 HRC

Part numbers

Tolerance h6	1000-xxx-00
Tolerance h7	1000-xxx-01

xxx = diameter in mm

Ordering example:

For a solid shaft of heat-treatable steel, 25 mm diameter, 460 mm length, tolerance quality h7

Part No. 1000-025-01, 460 mm

Solid shafts made of corrosion-resistant steel

to DIN 17230 / EN 10088

The correct choice for applications requiring high corrosion resistance in a clean environment, e.g. in the food industry, semiconductor manufacture and medical engineering. X 90 CrMoV 18 differs from X 46 Cr 13 in that it is additionally resistant to lactic acid.

Materials	Available diameters (mm)
X 46 Cr 13	5, 6, 8, 10, 12, 16, 20, 25, 30, 40, 50, 60, 80
X 90 CrMoV 18	12, 16, 20, 25, 30, 40, 50, 60, 80

Ø d (mm)	Lengths (m)
5-20	approx. 3.5 to 4.0
25-80	approx. 5.7 to 5.9

Greater overall lengths are composed of sections joined end-to-end.

STAR Linear Bushings can roll over joints without any problems.

Materials	Hardness
X 46 Cr 13	min. 54 HRC
X 90 CrMoV 18	min. 55 HRC

Part numbers

X 46 Cr 13		X 90 CrMoV 18	
Tolerance h6	1000-0xx-30	Tolerance h6	1000-0xx-20
Tolerance h7	1000-0xx-31	Tolerance h7	1000-0xx-21

xx = diameter in mm

Ordering example: For a solid shaft of corrosion-resistant steel X 46 Cr 13, 16 mm diameter, 350 mm length, tolerance quality h6

Part No. 1000-016-30, 350 mm

Solid shafts, hard chrome plated

Optimum anti-corrosion protection for applications in chemically aggressive environments, or for particularly attractive visual effect.

Available diameters (mm)
12, 16, 20, 25, 30, 40, 50, 60, 80

Ø d (mm)	Lengths (m)
12-20	approx. 3.5 to 4.0
25-80	approx. 5.7 to 5.9

Greater overall lengths are composed of sections joined end-to-end. STAR Linear Bushings can roll over joints without any problems.

Materials	Hardness
Cf 53, Cf 60, Ck 67	min. 60 HRC (approx. 700 HV)
Chrome plating (thickness approx. 10 µm)	approx. 1000 HV

Part numbers	
Tolerance h6	1000-0xx-60
Tolerance h7	1000-0xx-61

Ordering example:

For a solid shaft, hard chrome plated, 30 mm diameter, 480 mm length, tolerance quality h7
Part No. 1000-030-61, 480 mm

xx = diameter in mm

Solid shafts, with STAR-Resist coating

STAR-Resist provides inexpensive cathodic anti-corrosion protection for the steel base material through a zinc-iron coating with yellow chromating. The initial layer thickness of approx. 5 µm is compacted by rolling loads in the travel zone during the running-in cycles, thus canceling out the oversize. Cathodic action continues to protect the shaft from rusting even when the coating is slightly damaged.

Suitable for providing reliable anti-corrosion protection in applications involving a high level of humidity, changing climatic conditions with condensation, hand perspiration, or similar influences.

Not suitable for contact with food.

Available diameters (mm)
5, 8, 10, 12, 16, 20, 25, 30, 40, 50

The length of STAR-Resist-coated shafts is limited to around 3.5 m.

Greater overall lengths are composed of sections joined end-to-end. STAR Linear Bushings can roll over joints without any problems.

Materials	Hardness
Cf 53, Cf 60, Ck 67	min. 60 HRC

Part numbers	
Tolerance h6	1000-0xx-70
Tolerance h7	1000-0xx-71

xx = diameter in mm

Ordering example:

For a solid shaft, STAR-Resist-coated, 20 mm diameter, 450 mm length, tolerance quality h7
Part No. 1000-020-71, 450 mm

STAR – Precision Steel Shafts

Ordering Data

Tubular shafts made of heat-treatable steel

STAR Tubular Shafts can accommodate electric cables or carry liquid or gaseous media. Tubular shafts are also often used for weight-saving reasons. The material is seamlessly rolled, with the inner diameter left in the as-rolled condition.

Available diameters							
Outer diameter (mm)	25	30	40	50	60	80	100
Inner diameter (mm) (approx.)	14	19	26.5	29.6	36.5	57.4	65

Lengths: 5.5 to 5.9 m

Materials	Hardness
Ck 60	min. 60 HRC

Part numbers	
Tolerance h6	1001-xxx-10
Tolerance h7	1001-xxx-11

xxx = Outer diameter in mm

Ordering example:

For a tubular shaft, 80 mm diameter, 3600 mm length, tolerance quality h7

Part No. 1000-080-11, 3600 mm

Tubular shafts, hard chrome plated Tolerance h7

Available diameters (mm)						
Outer diameter	25	30	40	50	60	80
Inner diameter	14	19	26.5	29.6	36.5	57.4

Lengths:

5.5 to 5.9 m

Materials	Hardness
Ck 60	min. 60 HRC (approx. 700 HV)
Chrome plating (thickness approx. 10 µm)	approx. 1000 HV

Part number
1001-0xx-41

xx = Outer diameter in mm

Ordering example:

For a tubular shaft, hard chrome plated, 40 mm diameter, 2000 mm length, tolerance quality h7

Part No. 1001-040-41, 2000 mm

Solid shafts made of heat-treatable steel, inch sizes

Available diameters									
Ø (inch)	1/4	3/8	1/2	5/8	3/4	1	1 1/4	1 1/2	2
xx	04	06	08	10	12	16	20	24	32

Ø d (inch)	Lengths (m)
1/4 - 3/4	approx. 3.5 to 4.0
1 - 2	approx. 5.7 to 5.9

Greater overall lengths are composed of sections joined end-to-end. STAR Linear Bushings can roll over joints without any problems.

Materials	Hardness
Cf 53, Cf 60, Ck 67	min. 60 HRC

Part numbers	
Class "L"	1000-8xx-08
Class "S"	1000-8xx-09

xx: see table

Ordering example:

For a solid shaft of heat-treatable steel, 1/2 inch diameter, 800 mm length, class "S"

Part No. 1000-808-09, 800 mm

Solid shafts of corrosion-resistant steel to DIN 17230 / EN 10088, inch sizes

Available diameters				
Ø (inch)	1/2	3/4	1	1 1/2
xx	08	12	16	24

Ø d (inch)	Lengths (m)
1/2 - 3/4	approx. 3.5 to 4.0
1 - 1 1/2	approx. 5.7 to 5.9

Greater overall lengths are composed of sections joined end-to-end. STAR Linear Bushings can roll over joints without any problems.

Materials	Hardness
X 90 CrMoV 18 (resistant to lactic acid)	min. 55 HRC

Part numbers	
Class "L"	1000-8xx-28
Class "S" (on request)	1000-8xx-29

xx: see table

Ordering example:

For a solid shaft of corrosion-resistant steel X 90 CrMoV 18, 1 inch diameter, 2500 mm length, class "L"

Part No. 1000-816-28, 2500 mm

STAR – Shaft Support Rails

Shaft Support Rails are designed to support the shafts on which open-type Linear Bushings run to prevent them from bending under load.

Shaft Support Rails are delivered in ready-to-mount sections of high dimensional accuracy and are specially designed to give high rigidity. Their low overall height allows the construction of extra-compact linear motion assemblies.

Advantages

Shaft Support Rails

- prevent shaft deflection
- ensure efficient running of linear motion assemblies
- eliminate the need for users' own time-consuming and costly designs.

Shaft Support Rails are specially engineered sections manufactured mainly in standard lengths of 600 mm or 3000 mm. They can be mounted end to end for continuous shaft support or cut to any desired length for spaced support.

Ten different shaft support rails are available for shaft diameters from 12 to 80 mm. Intermediate shaft sizes can be mounted on the shaft support rail nearest in size to the shaft diameter. If in doubt, the next larger support rail should be used.

Shaft Support Rails are also (and in some cases exclusively) available with ready-mounted Precision Steel Shafts.



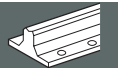
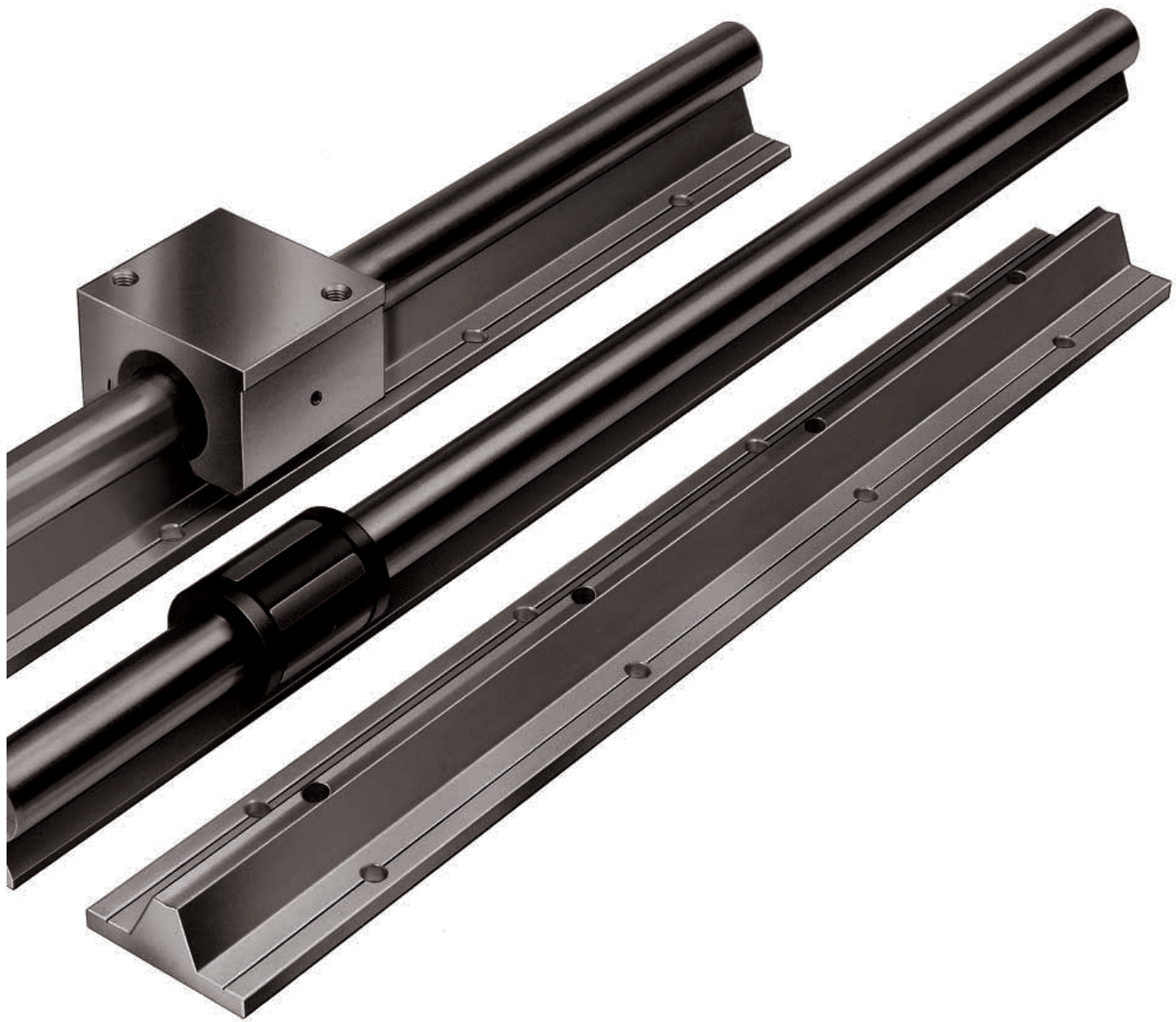

STAR – Shaft Support Rails with ready-mounted steel shafts

1. General

STAR can supply steel shafts ready-mounted on seven different types of shaft support rails. The individual support rails are arranged end to end underneath the corresponding shafts. Once the elements have been aligned and the linear motion assemblies screwed down onto a torsionally stiff, surface-machined base, the units will reflect the tolerances as given in the tables.

2. Part numbers

Type 1011 = Steel shaft with flanged aluminum shaft support rail, high-profile version
 1050-1...-..
 1050-2...-..

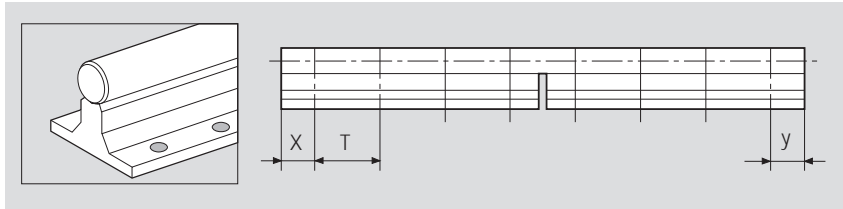

Type 1014 = Steel shaft with flanged aluminum shaft support rail, low-profile version
 1050-6...-..
 1050-7...-..

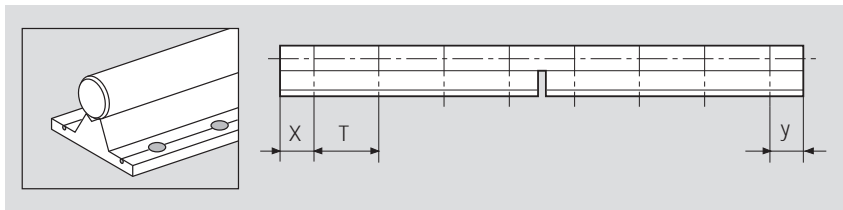

Type 1015 = Steel shaft with aluminum shaft support rail, for side mounting
 1054-1...-..
 1054-2...-..

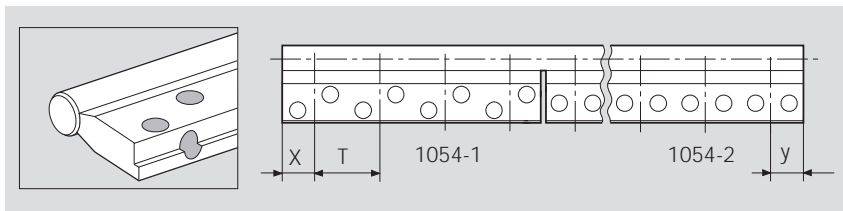

Type 1010 = Steel shaft with flanged aluminum shaft support rail, low-profile version, greater height tolerance, cost-effective (only available ready-mounted)

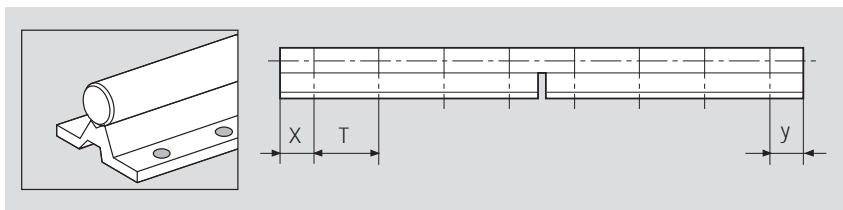

Type 1025 = Steel shaft with aluminum shaft support rail, for ALU-STAR Profile Systems, low-profile version

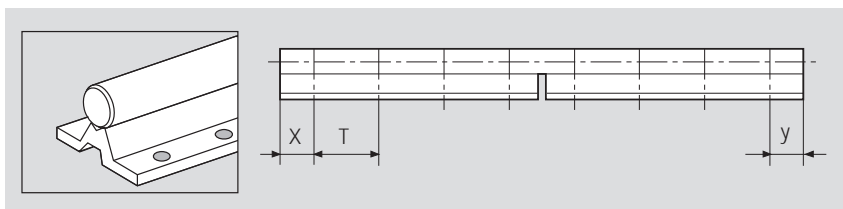

Type 1013 = Steel shaft with flangeless aluminum shaft support rail, greater height tolerance
(only available ready-mounted)

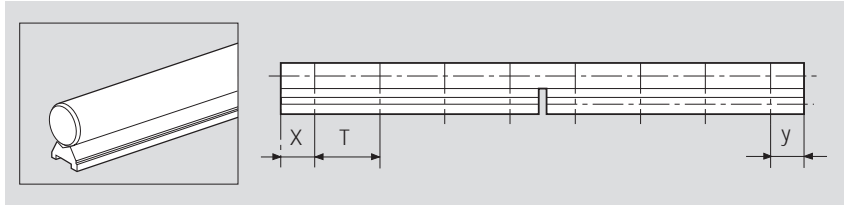

Type 1016 = Steel shaft with flangeless steel shaft support rail
(only available ready-mounted)

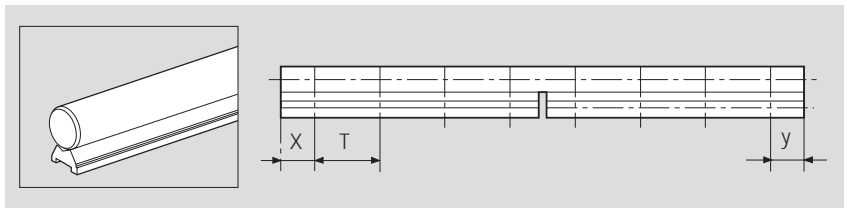

2.2 For use with Radial Linear Bushings

Type 1018 = Steel shaft with flanged steel shaft support rail
1052-1...-

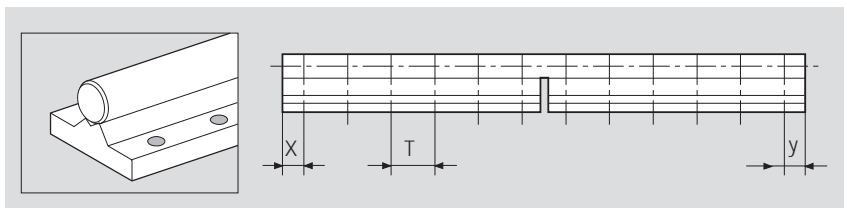

Type 1020 = Steel shaft with steel shaft support rail, for side mounting
1053-1...-

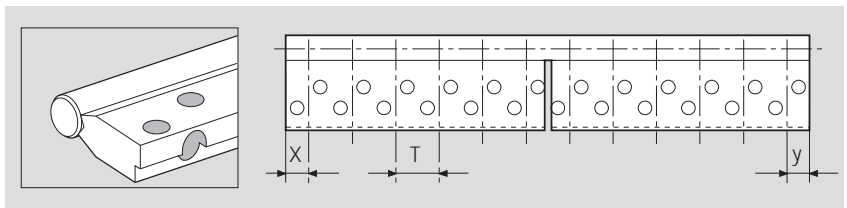

2.3 For use with Radial Compact Sets

Type 1012 = Steel shaft with special flanged steel shaft support rail for Radial Compact Sets
(only available ready-mounted)

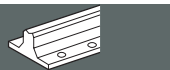
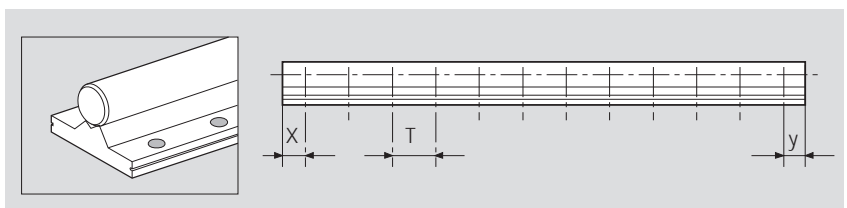

STAR – Shaft Support Rails with ready-mounted steel shafts

Design Hints, Ordering Data, Mounting

Design hints

a) Standardized Shaft Support Rails offer benefits:

Shaft Support Rails with hole spacing as specified in the catalog are always in stock. They are also more cost-effective as they are mass produced.

b) End spaces x and y

If the ordered shaft length is a whole multiple of the hole spacing dimension in a shaft support rail, the spaces at the ends of the rail will be half the pitch length (x and $y = T/2$). For other shaft lengths we make sure the holes are centered over the length ($x = y$). This is done by cutting off material at both ends of any overhanging shaft support rail. The end spaces x and y should not measure less than $0.2 \times T$.

If the customer has not supplied a drawing, our proposal and order confirmation will include the hole spacing we have determined for the steel shaft. This then gives the necessary location of the mounting holes in the machine bed. We recommend comparing this data with the machine design documents.

c) Extra-long and composite linear motion assemblies

A shaft section with mounted shaft support rail should not exceed 6 meters in length. Longer assemblies are composed of a number of sections fitted end to end by **plug-type** mounting. If the shaft sections are to be **screwed** together, the shaft support rails will have to be mounted at the customer's facility (see also section on "Composite Shafts"). The arrangement of joints in the shaft and the shaft support rail depends on the type of assembly. Basically, however, the joint in the shaft and the joint in shaft support rail must always be **staggered**.

Ordering data

To ensure prompt and smooth handling of your order, you can provide us with the required data according to the key given opposite.

An exact description of the required components or a drawing is also sufficient.

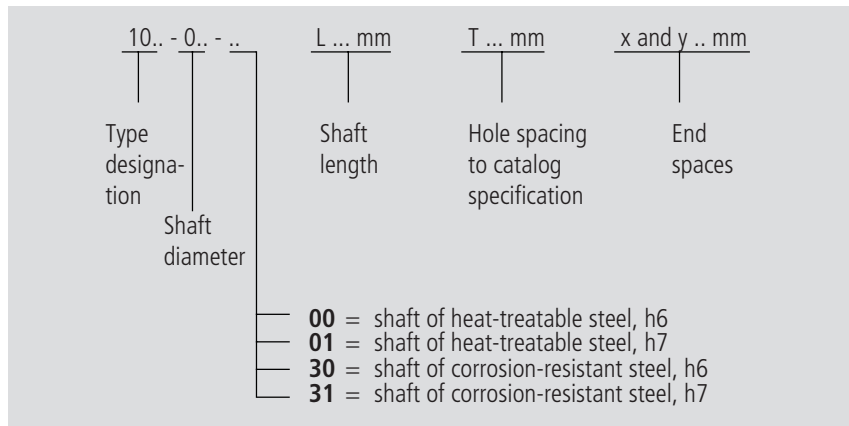

Examples of ordering text:

- a) For a shaft of heat-treatable steel, 30 mm diameter, 1200 mm length, tolerance quality h6, ready-mounted on shaft support rail 1050-630-00, the ordering data is: **1014-030-00 / L = 1200 / T = 150 / x and y = 75**
- b) For a shaft of corrosion-resistant steel, 40 mm diameter, 1100 mm length, tolerance quality h7, ready-mounted on shaft support rail 1050-140-00, the ordering data is: **1011-040-31 / L = 1100 / T = 200 / x and y = 50**

Mounting hint for flangeless shaft support rails

To facilitate mounting and in applications subject to major side loads, we recommend retention by means of a flat retaining strip or a wedge-profile as shown in the illustration below.

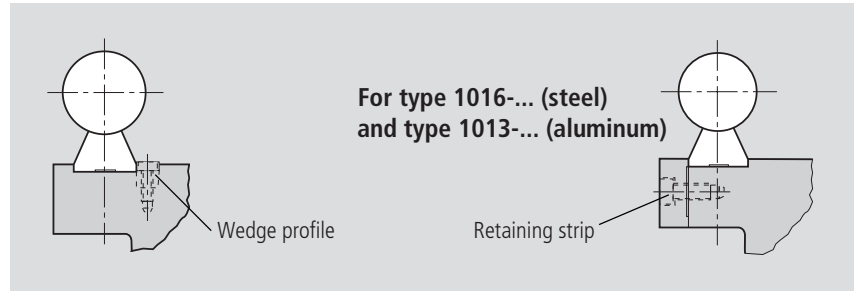

The shaft support rail must be carefully aligned for mounting as follows: push the first shaft and shaft support rail up against the fitting edge and screw down; then align the second shaft, preferably with the aid of a straightedge, and screw down. These elements are supplied only together with Precision Steel Shafts.

The maximum length of a support rail is 3000 mm; if longer lengths are required, the rails can be mounted end to end. The fitting edge allows easy alignment of the shaft support rails, thus avoiding any stressing of the linear bushings.

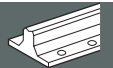
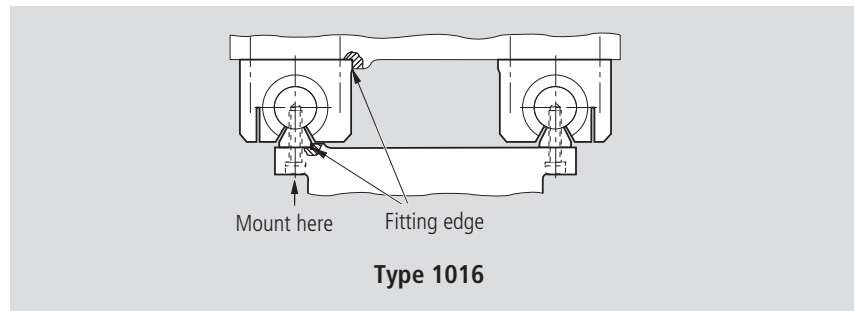

STAR – Shaft Support Rails with flange, high-profile version for open-type Standard and Super Linear Bushings

Shaft Support Rails, 1050-0..-00
without mounting holes for flange and shaft

Shaft Support Rails, 1050-1..-00
with mounting holes (spacing T_1) for higher side loads and higher precision

Shaft Support Rails, 1050-2..-00
with mounting holes (spacing T_2) for applications subject to general requirements

Material

- Aluminum

Ordering data



Shaft $\varnothing d$ (mm)	Part numbers	Mass (kg)
12	1050-.12-00	0.64
16	1050-.16-00	0.74
20	1050-.20-00	1.00
25	1050-.25-00	1.20
30	1050-.30-00	1.80
40	1050-.40-00	2.10
50	1050-.50-00	3.00
60	1050-.60-00	4.00
80	1050-.80-00	6.30

Also available with ready-mounted shaft (see chapter on "Shaft Support Rails with ready-mounted steel shafts")

Dimensions

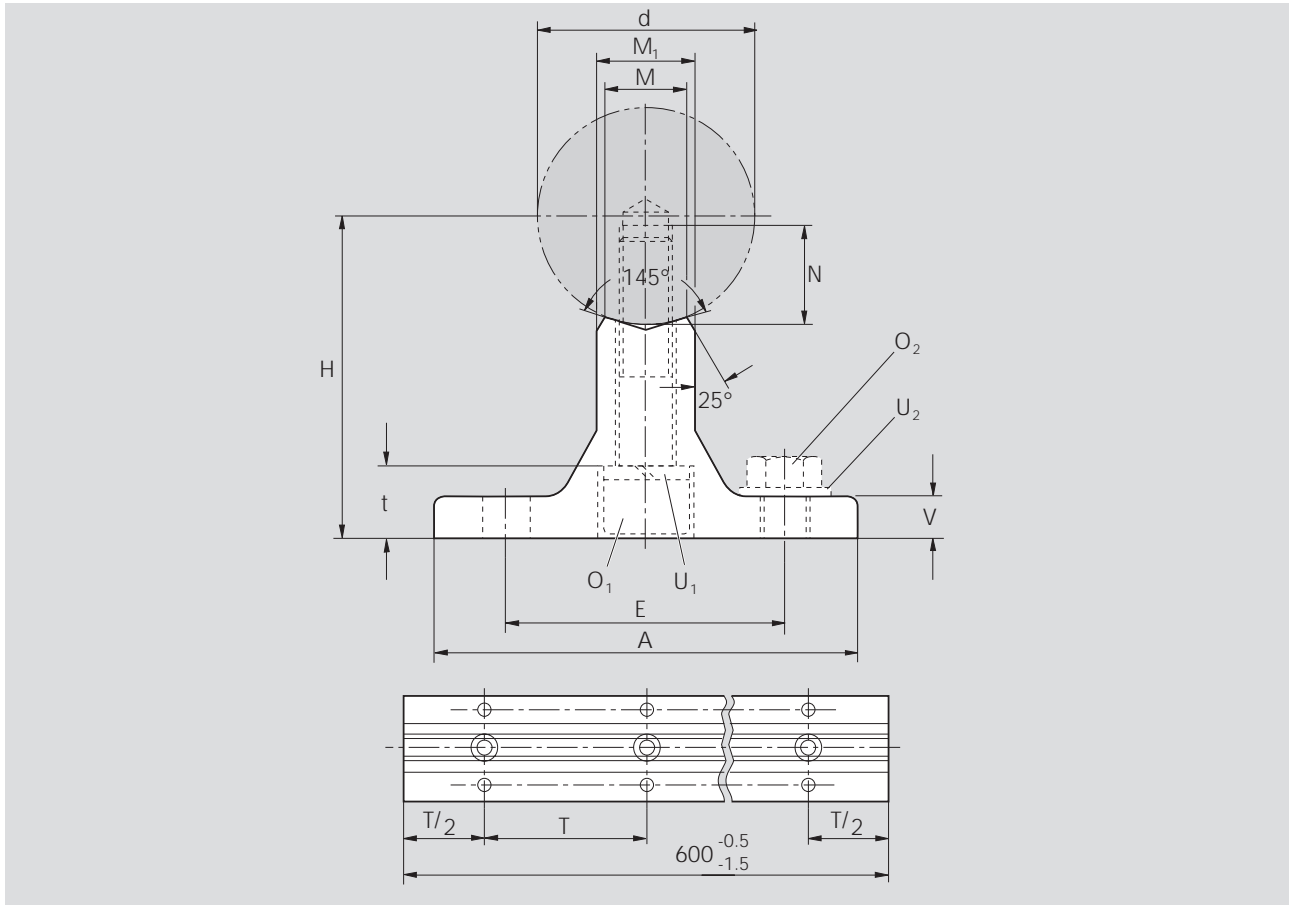

$\varnothing d$	$H^1)$ ± 0.01	Dimensions (mm)											Hole spacing ³⁾	
		A	V	M	M_1	O_1 ISO 4762-8.8	U_1 DIN 7980	N	E	t	$O_2^{2)}$ ISO 4762-8.8 or ISO 4017-8.8	U_2 DIN 125	T_1	T_2
12	28	43	5	5.8	9	M4x25	4	8	29	5.5	M4x12	4	75	120
16	30	48	5	7	10	M5x25	5	9	33	7	M5x16	5	100	150
20	38	56	6	8.3	11	M6x30	6	11	37	9.6	M6x16	6	100	150
25	42	60	6	10.8	14	M8x35	8	15	42	11	M6x16	6	120	200
30	53	74	8	11	14	M10x40	10	17	51	14	M8x25	8	150	200
40	60	78	8	15	18	M10x45	10	19	55	13.5	M8x25	8	200	300
50	75	90	10	19	22	M12x55	12	21	63	16	M10x30	10	200	300
60	80	100	12	25	30	M14x55	14	25	72	19	M10x30	10	300	–
80	100	125	14	34	42	M16x65	16	28	92	21.5	M12x35	12	300	–

Where extra-high precision and rigidity are required, the pitch of the center row of mounting holes (for attachment of the shaft) should be reduced to $0.5 T_1$.

¹⁾ Relative to nominal shaft dimension d , measured when screwed to base mounting surface.

²⁾ Applies only to fixing in tapped holes in steel or cast iron.

³⁾ T_1 : for applications in which the load acts transverse to the open portion of the bushing and load capacity is near the load rating limit, or where high dimensional accuracy is required.

T_2 : for applications subject to general requirements.

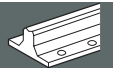

STAR – Shaft Support Rails with flange, low-profile version for open-type Standard and Super Linear Bushings

Shaft Support Rails, 1050-5..-00
without mounting holes

Shaft Support Rails, 1050-6..-00
hole spacing T₁

Shaft Support Rails, 1050-7..-00
hole spacing T₂

Material

- Aluminum

Advantages

- Low overall height
Used in conjunction with Linear Sets, these shaft support rails give linear motion assemblies with extremely low overall as-installed heights.
- High rigidity
The shaft bearing surface of the support rail is matched to the diameter of the mating-size shaft to ensure that the shaft bearing pressure acts at the optimum angle; together with the sturdy dimensions of the mounting screws, this guarantees high rigidity.

Ordering data

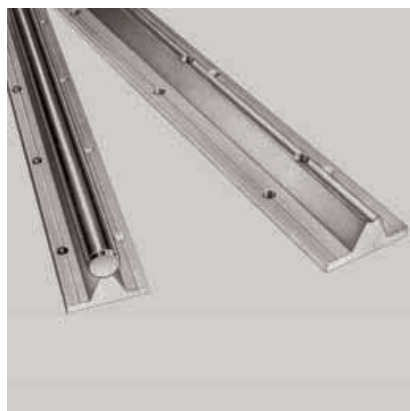

Shaft Ø d (mm)	Part numbers	Mass (kg)
12	1050-.12-00	0.52
16	1050-.16-00	0.64
20	1050-.20-00	0.90
25	1050-.25-00	1.08
30	1050-.30-00	1.43
40	1050-.40-00	1.81
50	1050-.50-00	2.45
60	1050-.60-00	3.16
80	1050-.80-00	4.86

Also available with ready-mounted shaft (see chapter on "Shaft Support Rails with ready-mounted steel shafts")

Dimensions

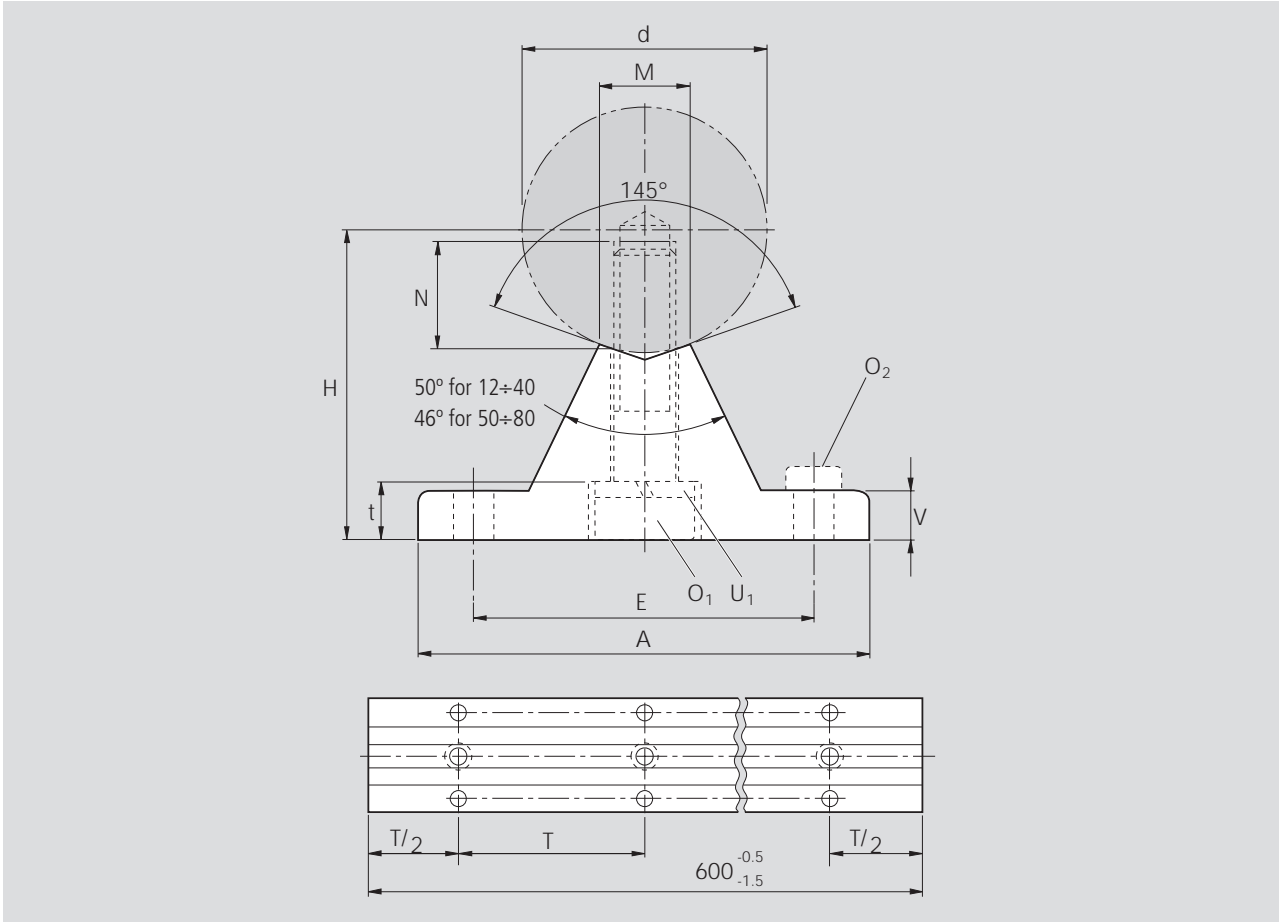

Ø d	H ¹⁾ ±0.01	Dimensions (mm)									Hole spacing ³⁾	
		A	V	M	O ₁ DIN6912-8.8	U ₁ DIN7980	N	E	t	O ₂ ²⁾ DIN6912-8.8	T ₁	T ₂
12	22	40	5	5.8	M4x20	4	8	29	4.5	M4x12	75	120
16	26	45	5	7	M5x20	5	9	33	7.6	M5x16	100	150
20	32	52	6	8.3	M6x25	6	11	37	8.6	M6x16	100	150
25	36	57	6	10.8	M8x30	8	15	42	9	M6x16	120	200
30	42	69	7	11	M10x35	10	17	51	10	M8x25	150	200
40	50	73	8	15	M10x40	10	19	55	9.5	M8x25	200	300
50	60	84	9	19	M12x45	12	21	63	11.5	M10x30	200	300
60	68	94	10	25	M14x50	14	25	72	13	M10x30	300	-
80	86	116	12	34	M16x60	16	28	92	15	M12x35	300	-

Where extra-high precision and rigidity are required, the pitch of the center row of mounting holes (for attachment of the shaft) should be reduced to 0.5 T₁.

¹⁾ Relative to nominal shaft dimension d, measured when screwed to base mounting surface.

²⁾ Applies only to fixing in tapped holes in steel or cast iron.

³⁾ T₁: for applications in which the load acts transverse to the open portion of the bushing and load capacity is near the load rating limit, or where high dimensional accuracy is required.

T₂: for applications subject to general requirements.

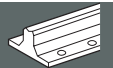

STAR – Shaft Support Rails side mounting for open-type Standard and Super Linear Bushings

Shaft Support Rails, 1054-1..-00

with fitting edge

for applications with stringent precision and rigidity requirements

Shaft Support Rails, 1054-2..-00

with fitting edge

for applications with general precision and rigidity requirements

Material

- Aluminum

Ordering data



Shaft Ø d (mm)	Part numbers	Mass (kg)
20	1054-120-00	1.0
25	1054-125-00	1.3
30	1054-130-00	1.9
40	1054-140-00	2.7
50	1054-150-00	3.7



Shaft Ø d (mm)	Part numbers	Mass (kg)
20	1054-220-00	1.1
25	1054-225-00	1.5
30	1054-230-00	2.1
40	1054-240-00	3.0
50	1054-250-00	4.2

Also available with ready-mounted shaft (see chapter on "Shaft Support Rails with ready-mounted steel shafts")

Dimensions

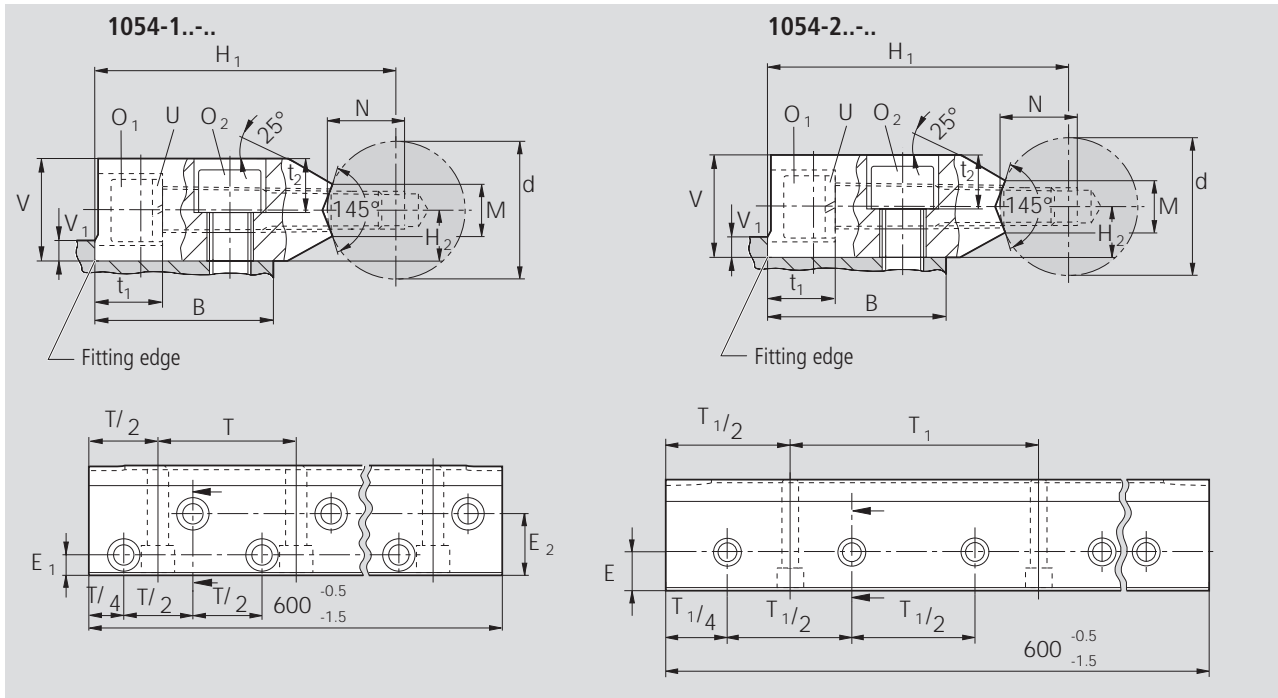

1054-1-...

Ø d	Dimensions (mm)														
	H ₁ ¹⁾ js6	H ₂ ¹⁾ ±0.012	V	M	E ₁ ±0.15	E ₂ ±0.15	T	t ₁	t ₂	V ₁ ²⁾ max.	B ²⁾	N	O ₁ ISO 4762-8.8	O ₂ ³⁾ ISO 4762-8.8	U DIN 7980
20	52	7.5	15	8.3	8	22	75	8.5	8.5	4	30	11	M6x45	M6x16	6
25	62	10	20	10.8	10	26	75	15	11	5.5	36	15	M8x50	M8x20	8
30	72	12.5	25	11	12	30	100	15.3	13.5	7	42	17	M10x60	M10x25	10
40	88	15	30	15	12	38	100	19	16	8.5	50	21	M12x70	M12x30	12
50	105	17.5	35	19	15	45	100	24	18.5	9	60	25	M14x80	M14x35	14

1054-2-...

Ø d	Dimensions (mm)													
	H ₁ ¹⁾ js6	H ₂ ¹⁾ ±0.012	V	M	E ±0.15	T ₁	t ₁	t ₂	V ₁ ²⁾ max.	B ²⁾	N	O ₁ ISO 4762-8.8	O ₂ ³⁾ ISO 4762-8.8	U DIN 7980
20	52	7.5	15	8.3	15	100	8.5	8.5	4	30	11	M6x45	M6x16	6
25	62	10	20	10.8	18	120	15	11	5.5	36	15	M8x50	M8x20	8
30	72	12.5	25	11	21	150	15.3	13.5	7	42	17	M10x60	M10x25	10
40	88	15	30	15	25	200	17.5	16	8.5	50	19	M10x70	M12x30	10
50	105	17.5	35	19	30	200	21.5	18.5	9	60	21	M12x80	M14x35	12

¹⁾ Relative to nominal shaft dimension d, measured when screwed to base mounting surface.

²⁾ Recommended design: make mating surface without fitting edge (V₁) and line up parallel via the shafts.

³⁾ Applies only to fixing in tapped holes in steel or cast iron.

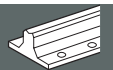

STAR – Shaft Support Rails with flange, low-profile version for open-type Standard and Super Linear Bushings

Shaft Support Rails, 1010- with Precision Steel Shaft

Material

- Support rail: aluminum
- Shaft: steel

Advantages

- Low overall height
Used in conjunction with Linear Sets, these shaft support rails make it possible to build linear motion guideways with an extremely low overall height.
- High rigidity
The shaft bearing surface of the support rail is matched to the diameter of the mating-size shaft to ensure that the shaft bearing pressure acts at the optimum angle; together with the sturdy mounting screws, this guarantees high rigidity.
- Cost-effective use
Greater height tolerances permit easy and cost-effective assembly of supported guideways.

Ordering data



Shaft Ø d (mm)	Part numbers	Mass with shaft (kg/m)
16	1010-016-..	2.5
20	1010-020-..	3.8
25	1010-025-..	5.4
30	1010-030-..	7.6
40	1010-040-..	12.6

available as of the year 2000

- 00 = shaft of heat-treatable steel, h6
- 01 = shaft of heat-treatable steel, h7
- 30 = shaft of corrosion-resistant steel, h6
- 31 = shaft of corrosion-resistant steel, h7

Ordering example:

For a shaft support rail with a shaft of heat-treatable steel, 30 mm diameter, 900 mm length, tolerance quality h7:

1010-030-01 / 900 mm.

Only available with ready-mounted shaft.

Dimensions

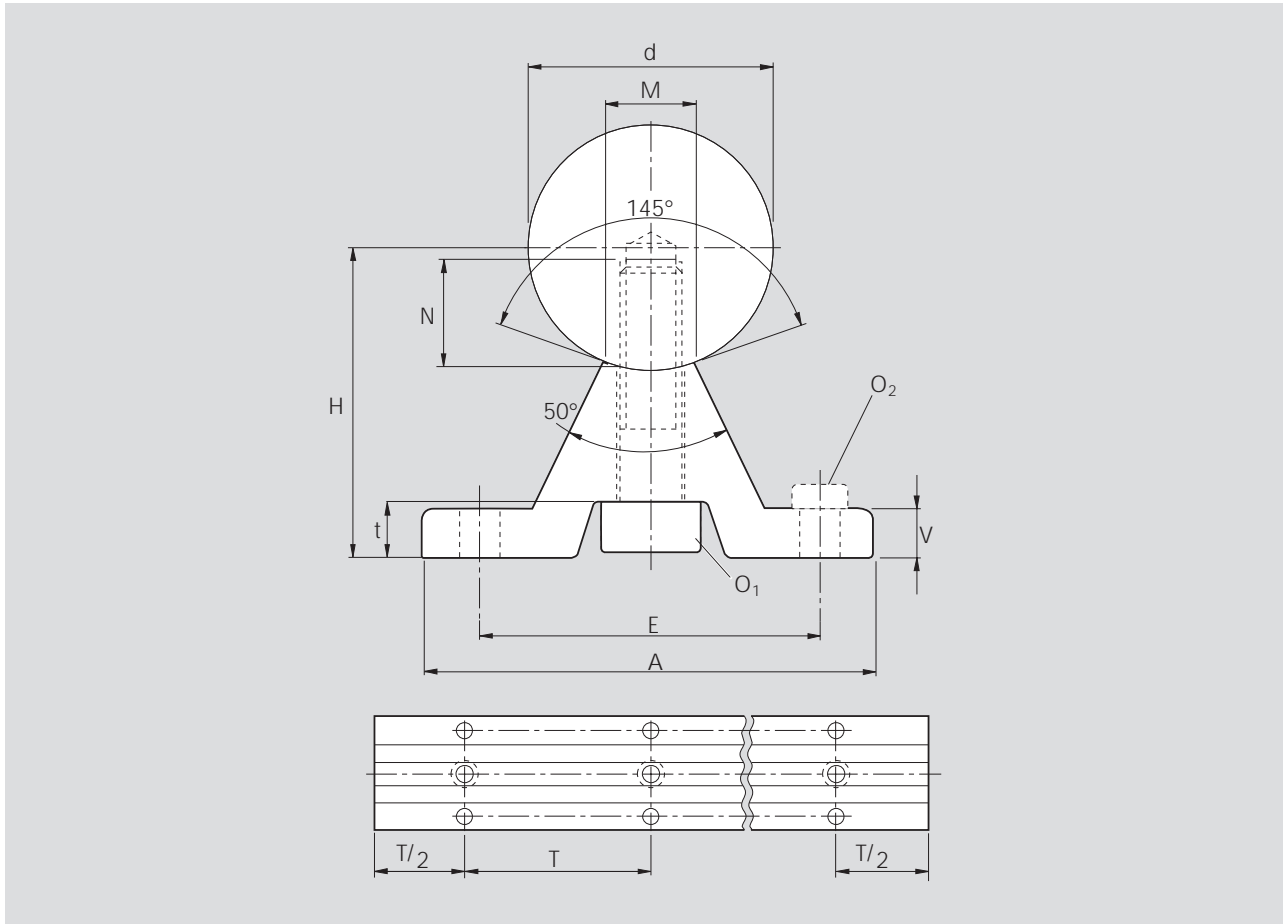

$\varnothing d$	H ¹⁾ ± 0.1	A	V	M	O ₁		E	t	O ₂ ²⁾		T
					DIN 6912-8.8				DIN 6912-8.8		
16	26	45	5	7	M5x20		9	33	6	M5x16	100
20	32	52	6	8.3	M6x25		11	37	7	M6x16	100
25	36	57	6	10.8	M8x30		15	42	7	M6x16	120
30	42	69	7	11	M10x35		17	51	7.5	M8x25	150
40	50	73	8	15	M10x40		19	55	7	M8x25	200

¹⁾ Measured with gauging shaft of nominal diameter d and length approx. 50 mm. Lengths up to 3000 mm with a parallelism of 0.1 mm on request.

²⁾ Applies only to fixing in tapped holes in steel or cast iron.

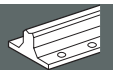

STAR – Shaft Support Rails for ALU-STAR Profile Systems for open-type Standard and Super Linear Bushings

Shaft Support Rails, 1025- with Precision Steel Shaft

Material

- Support rail: aluminum
- Shaft: steel

Advantages

- Fast and easy, modular assembly of linear bushings and shafts on profile systems

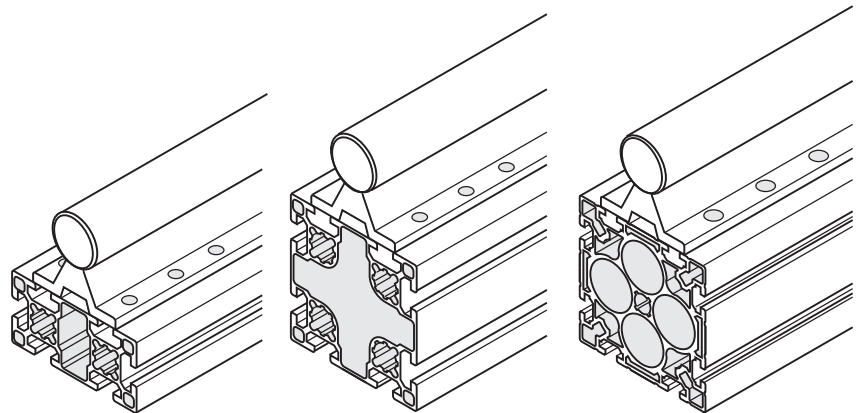

Ordering data

support rails, with shaft

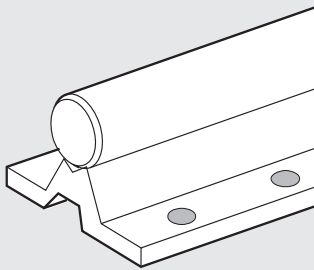

support rails, with drilled holes

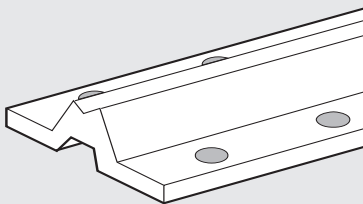

support rails, without drilled holes

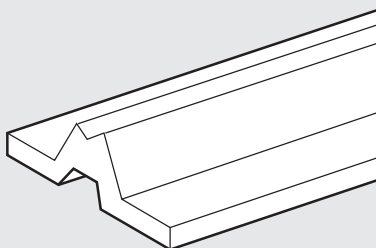

Shaft Ø d (mm)	Part numbers	Mass with shaft (kg/m)	Combinable with ALU-STAR Profile	
			profile width (mm)	groove spacing (mm)
20	1025-020-..	3.8	80	40
25	1025-025-..	5.4	80	40
30	1025-030-..	7.5	100	50

Support rails with drilled holes, with shaft ¹⁾

- 00 = shaft of heat-treatable steel, h6
- 01 = shaft of heat-treatable steel, h7
- 30 = shaft of corrosion-resistant steel, h6
- 31 = shaft of corrosion-resistant steel, h7

¹⁾ Shaft support rail and shaft are supplied unmounted.

Ordering example:

For a shaft support rail with a shaft of heat-treatable steel, 25 mm diameter, 900 mm length, tolerance quality h7:

1025-025-01 / 900 mm.

Shaft support rails with drilled holes, without shaft			
Shaft Ø d (mm)	Part numbers	Mass (kg/m)	Length (mm)
20	1039-820-00	1.3	2880 ^{-0.5} _{-1.5}
25	1039-825-00	1.6	2880 ^{-0.5} _{-1.5}
30	1039-830-00	2.0	2880 ^{-0.5} _{-1.5}

Shaft support rails without drilled holes, without shaft			
Shaft Ø d (mm)	Part numbers	Mass (kg/m)	Length (mm)
20	1039-520-00	1.3	3000 ^{-0.5} _{-1.5}
25	1039-525-00	1.6	3000 ^{-0.5} _{-1.5}
30	1039-530-00	2.1	3000 ^{-0.5} _{-1.5}

available as of the year 2000

Dimensions

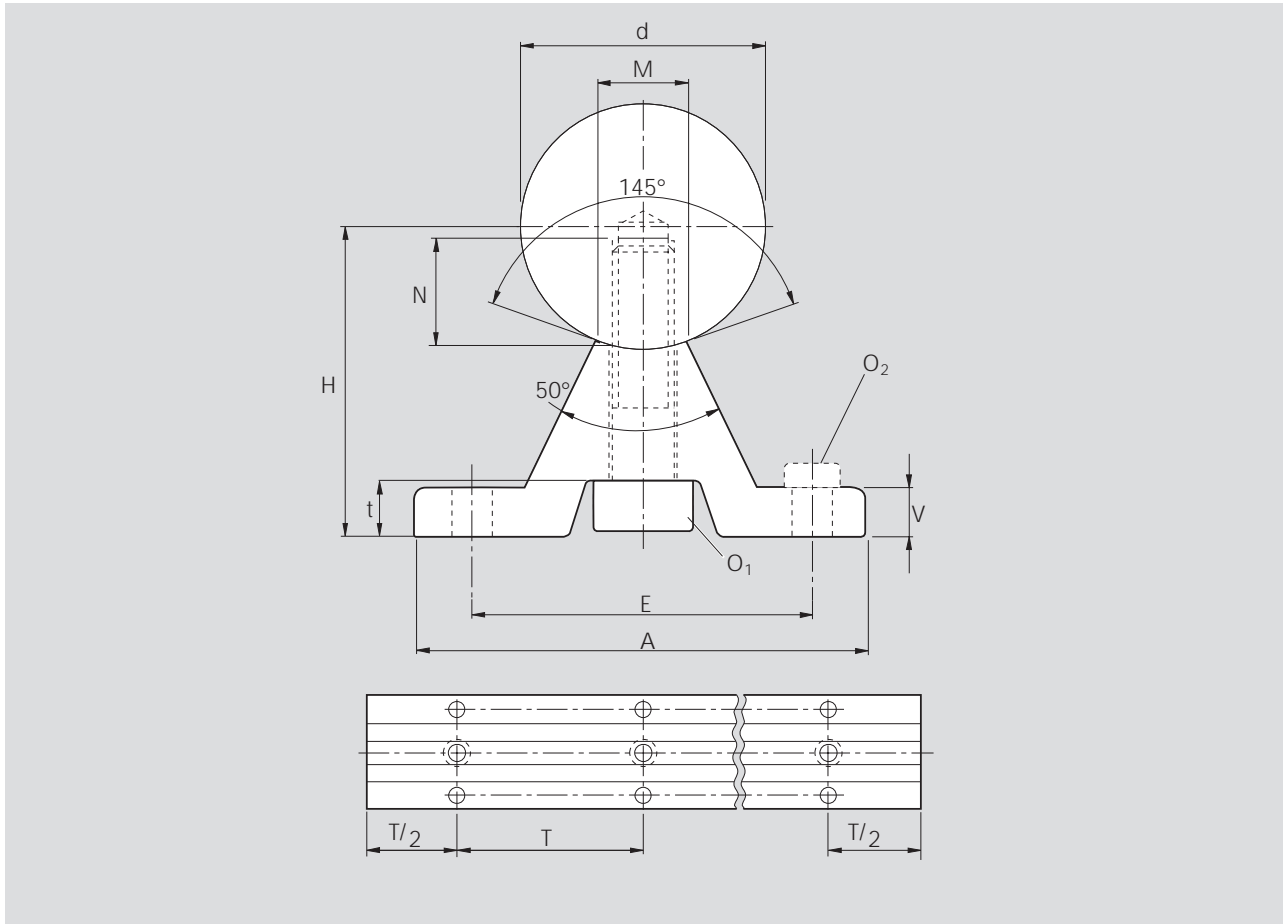

Dimensions (mm)										
$\varnothing d$	$H^{1)}$ ± 0.1	A	V	M	O_1 DIN 6912-8.8	N	E	t	O_2 DIN 6912-8.8	T
20	32	52	6	8.3	M6x25	11	40	7	M6	180
25	36	57	6	10.8	M8x30	15	40	7	M6	180
30	42	69	7	11	M10x35	17	50	7.5	M8	180

¹⁾ Measured with gauging shaft of nominal diameter d and length approx. 50 mm. Lengths up to 3000 mm with a parallelism of 0.1 mm on request.

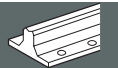

STAR – Shaft Support Rails without flange for open-type Standard and Super Linear Bushings

Shaft Support Rails, 1013- without flange, with Precision Steel Shaft

Material

- Support rail: aluminum
- Shaft: steel

Advantages

- These shaft support rails permit very compact linear motion guideways and are ideal for designs where the steel shaft can be mounted from below. Compared with common flanged designs (see illustration), this element builds exceptionally low.
- Cost-effective use
Greater height tolerances allow simple and cost-effective assembly of supported guideways.

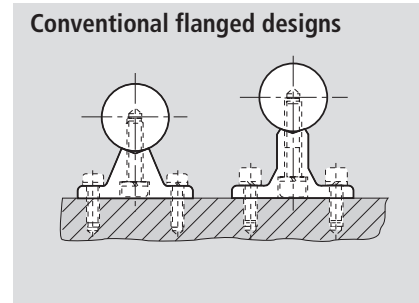
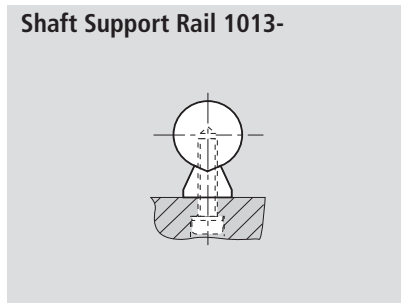

Ordering data



Shaft Ø d (mm)	Part numbers	Mass with shaft (kg/m)
12	1013-012-..	1.1
16	1013-016-..	1.9
20	1013-020-..	3.0
25	1013-025-..	4.5
30	1013-030-..	6.3

- 00 = shaft of heat-treatable steel, h6
- 01 = shaft of heat-treatable steel, h7
- 30 = shaft of corrosion-resistant steel, h6
- 31 = shaft of corrosion-resistant steel, h7

Ordering example:

For a shaft support rail with a shaft of heat-treatable steel, 25 mm diameter, 2500 mm length, tolerance quality h7:

1016-025-01 / 2500 mm.

Only available with ready-mounted shaft.

Dimensions

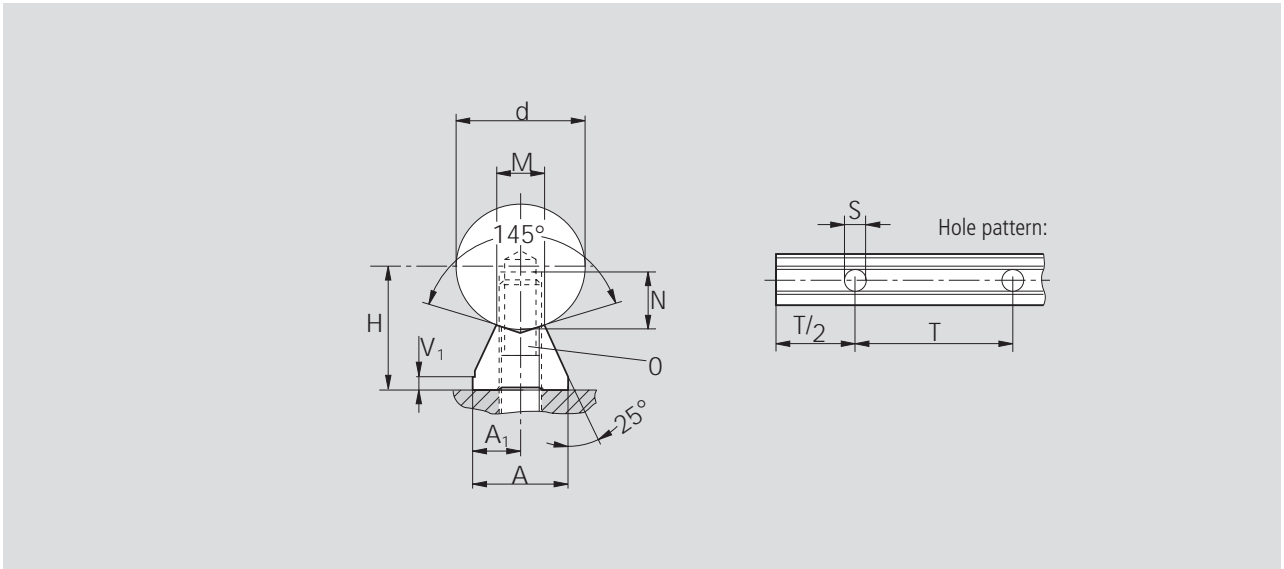

$\varnothing d$	$H^{1)}$ ± 0.05	Dimensions (mm)							
		A	A_1	V_1	T	S	N	M	O ISO 4762-8.8
12	14.5	11	5.5	3	75	4.5	8	5.8	M4
16	18	14	7	3	75	5.5	9	7	M5
20	22	17	8.5	3	75	6.6	11	8.3	M6
25	26	21	10.5	3	75	9	15	10.8	M8
30	30	23	11.5	3	100	11	17	11	M10

¹⁾ Measured with gauging shaft of nominal diameter d and length approx. 50 mm. Lengths up to 3000 mm with a parallelism of $50 \mu\text{m}$ on request.

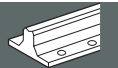

STAR – Shaft Support Rails without flange for open-type Standard and Super Linear Bushings

Shaft Support Rails, 1016-
with fitting edge, with Precision Steel Shaft

Material

- Steel

These steel shaft support rails produce very compact linear motion assemblies and are ideal for designs where the steel shaft can be mounted from below. Compared with common flanged designs (see illustration), this element builds exceptionally low.

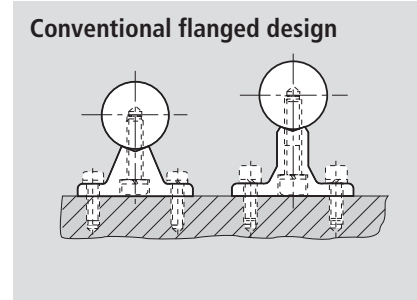
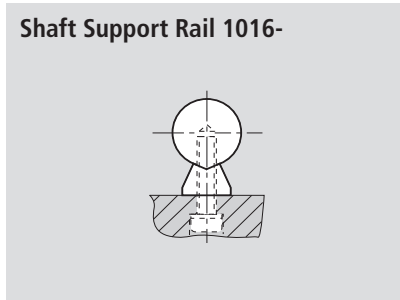

Ordering data



Shaft Ø d (mm)	Part numbers	Mass with shaft (kg/m)
16	1016-016-..	2.5
20	1016-020-..	3.8
25	1016-025-..	5.6
30	1016-030-..	7.6
40	1016-040-..	13.4
50	1016-050-..	20.2

- 00 = shaft of heat-treatable steel, h6
- 01 = shaft of heat-treatable steel, h7
- 30 = shaft of corrosion-resistant steel, h6
- 31 = shaft of corrosion-resistant steel, h7

Ordering example:

For a shaft support rail with shaft of heat-treatable steel, 30 mm diameter, 900 mm length, tolerance quality h7, the ordering data is:

1016-030-01 / 900 mm.

Only available with ready-mounted shaft.

Dimensions

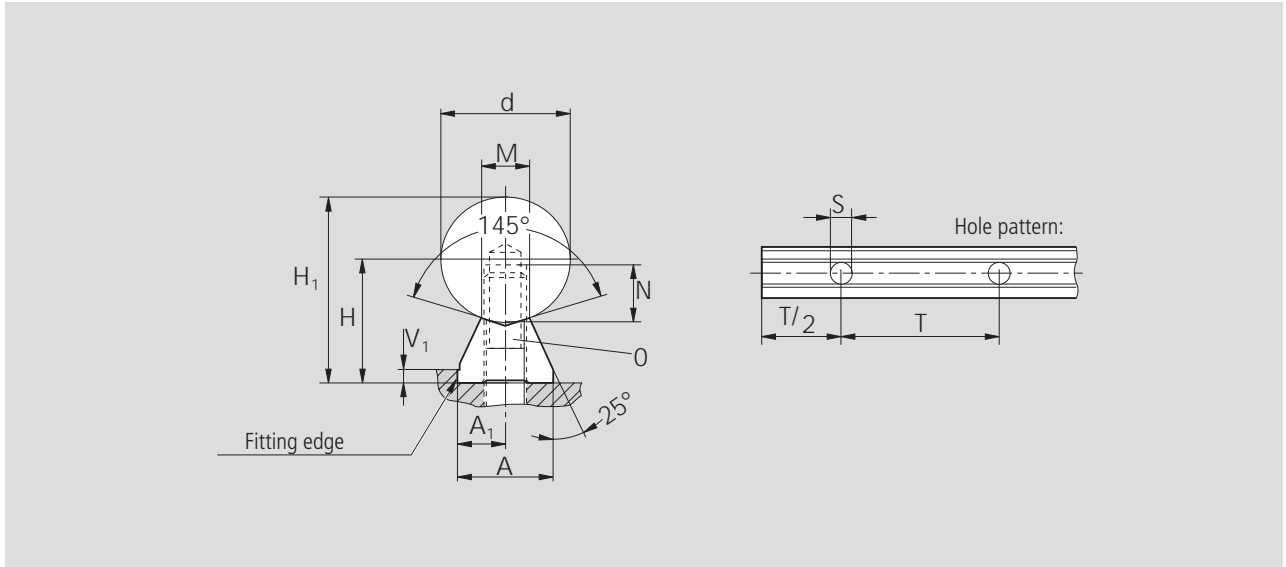

Ø d	Dimensions (mm)										Tolerances within one grade (µm)		
	H ¹⁾	H ₁	A ±0.02	A ₁ ±0.02	V ₁	T	S	N	M	O ISO 4762-8.8	H ²⁾	Shaft h6 H ₁ ³⁾	Shaft h7 H ₁ ³⁾
16	18	26	14	7	3	75	5.5	9	7	M5	20	32	36
20	22	32	17	8.5	3	75	6.6	11	8.3	M6	20	33	38
25	26	38.5	21	10.5	3	75	9	15	10.8	M8	20	33	38
30	30	45	23	11.5	3	100	11	17	11	M10	20	33	38
40	39	59	30	15	4	100	13.5	21	15	M12	20	35	41
50	46	71	35	17.5	5	100	15.5	25	19	M14	20	35	41

1) Tolerance +0.02 mm; delivered graded by height to 20 µm.

2) Measured with gauging shaft of nominal diameter d and length approx. 50 mm. Lengths up to 3000 mm with a parallelism of 10 µm on request.

3) Including shaft tolerance, measured when screwed to base mounting surface (statistically determined).

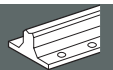

STAR – Shaft Support Rails with flange for Radial Linear Bushings

Shaft Support Rails, 1052- with fitting edge

These steel shaft support rails afford very high rigidity even when full advantage is taken of the high load capacity of the linear bushings.

Material

- Steel

Ordering data



Shaft Ø d (mm)	Part numbers	Mass (kg)
30	1052-130-00	9.0
40	1052-140-00	12.7
50	1052-150-00	20.7
60	1052-160-00	29.0
80	1052-180-00	48.9

Also available with ready-mounted shaft (see Chapter "Shaft Support Rails with ready-mounted steel shafts").

Dimensions

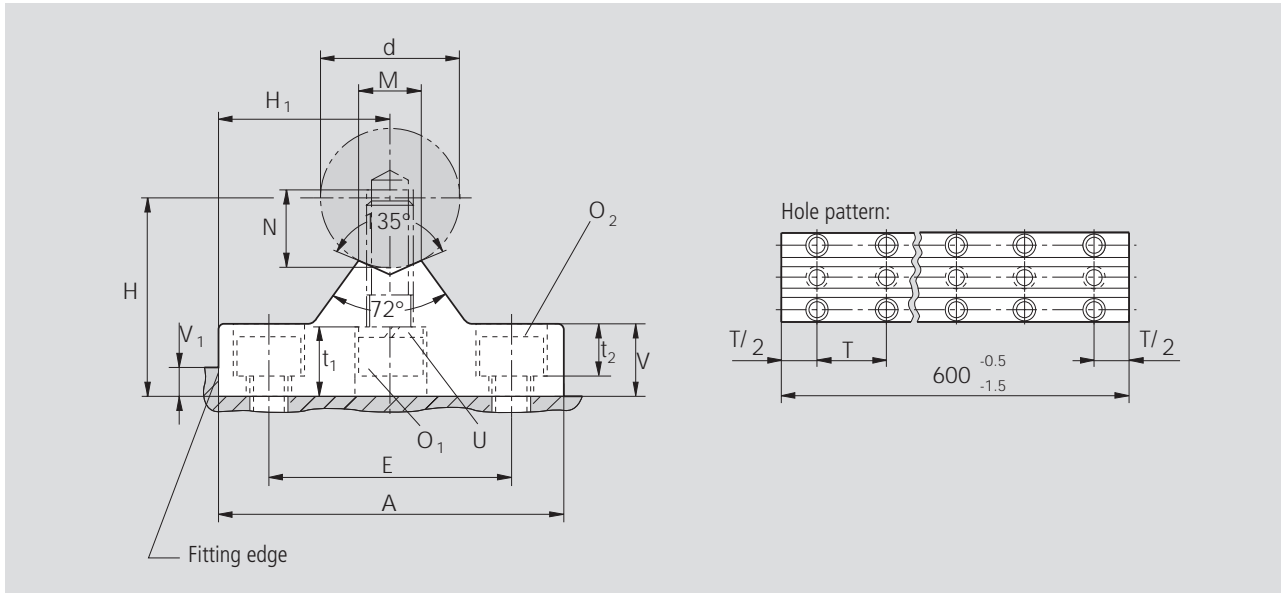

$\varnothing d$	Dimensions (mm)													
	A	$H_1^{1)}$ js6	$H_1^{2)}$ js6	V	$V_1^{3)}$	M -0.5	E	T	t_1	t_2	N	O_1 ISO 4762-8.8	O_2 DIN 7980	U
30	80	50	40	19	7	13	55	60	22	13.5	17	M10x30	M10	10
40	100	60	50	22	8.5	18	70	75	22	16	21	M12x40	M12	12
50	125	75	62.5	30	9	23	90	100	28	21	28	M16x50	M16	16
60	150	90	75	34	13	27	110	120	34	25.5	32	M20x60	M20	20
80	200	115	100	42	18	37	140	150	38.5	30.5	40	M24x80	M24	24

¹⁾ Relative to nominal shaft dimension d , measured when screwed to base mounting surface.

²⁾ Applies exclusively at height V_1 .

³⁾ Recommended design: make mating surface without fitting edge (V_1) and line up parallel via the shafts.

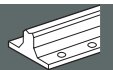

STAR – Shaft Support Rails side mounting for Radial Linear Bushings

Shaft Support Rails, 1053- with fitting edge

These steel shaft support rails afford very high rigidity even when full advantage is taken of the high load capacity of the linear bushings.

Material

- Steel

Ordering data



Shaft Ø d (mm)	Part numbers	Mass (kg)
30	1053-130-00	8.7
40	1053-140-00	15.5
50	1053-150-00	23.0
60	1053-160-00	36.0
80	1053-180-00	58.0

Also available with ready-mounted shaft (see Chapter "Shaft Support Rails with ready-mounted steel shafts").

Dimensions

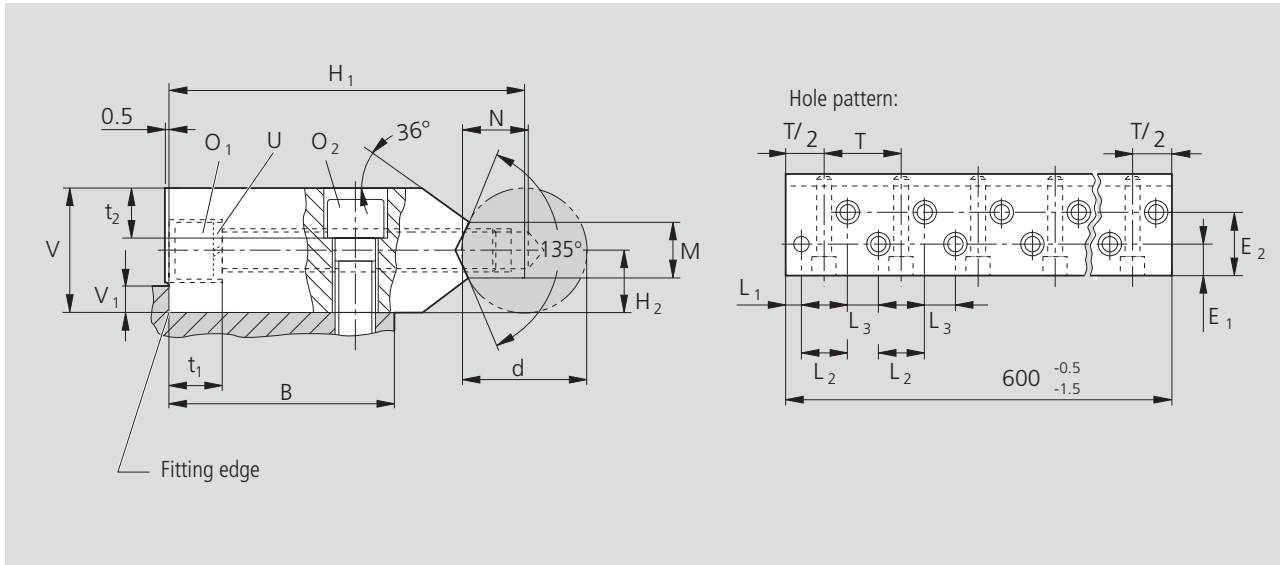

Ø d	Dimensions (mm)																		
	H ₁	H ₂ ¹⁾	V	V ₁ ²⁾	M	E ₁	E ₂	T	L ₁	L ₂	L ₃	t ₁	t ₂	B ³⁾	N	O ₁	O ₂ ⁴⁾	U	
	±0.01	±0.01		max.	-0.5	±0.2	±0.2									ISO 4762-8.8		DIN 7980	
30	90	15	30	7	13	23	46	60	12	36	24	13.5	13.5	57	17	M10x80	M10x30	10	
40	115	20	40	8.5	18	30	60	75	15	45	30	16	16	73	21	M12x100	M12x40	12	
50	140	25	50	9	23	38	76	100	20	60	40	23	21	92	28	M16x120	M16x50	16	
60	180	30	60	13	27	50	100	120	24	72	48	25.5	25.5	120	32	M20x160	M20x60	20	
80	220	40	80	18	37	60	120	150	30	90	60	44	30.5	145	40	M24x180	M24x80	24	

- 1) Relative to nominal shaft dimension d, measured when screwed to base mounting surface.
- 2) Recommended design: make mating surface without fitting edge (V₁) and line up parallel via the shafts.
- 3) Recommended design for connecting parts.
- 4) Applies only to fixing in tapped holes in steel or cast iron.

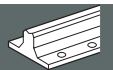

STAR – Shaft Support Rails with flange for Radial Compact Sets

**Shaft Support Rails, 1012-
with fitting edge
with Precision Steel Shaft h6 of heat-treatable steel**

Material

- Steel

Mounting procedure

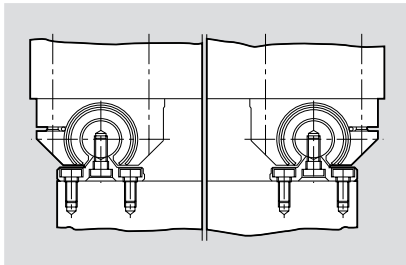

Without fitting edge

- Align first shaft with the support rail (ready-mounted unit), using a straightedge, and screw into place.
- Align second shaft in parallel, preferably using a straightedge (see "Parallelism", General Technical Data and Mounting Instructions) and screw shaft support rail in place.
- Push Radial Compact Sets onto the shafts and screw into place on the machine table.

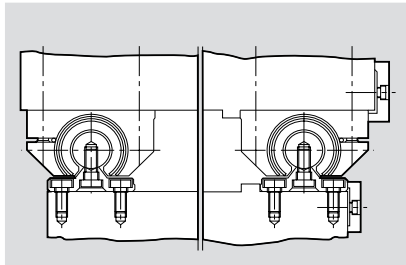

With fitting edge

- One fitting edge on the machine base and one on the machine table, or
 - only one fitting edge on the machine base.
- Press first shaft with support rail against fitting edge and screw into place.
 - Align second shaft in parallel, preferably using a straightedge (see "Parallelism", General Technical Data and Mounting Instructions) and screw shaft support rail into place.
 - Push Radial Compact Sets onto the shafts and
 - press Radial Compact Sets of the first shaft against fitting edge of the machine table and screw into place; then screw Radial Compact Sets of the second shaft into place on machine table, or
 - screw Radial Compact Sets into place on machine table.

Ordering data

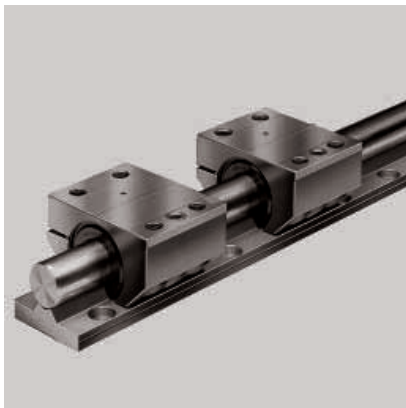

Shaft Ø d (mm)	Part numbers	Mass with shaft (kg/m)
30	1012-030-00	12.3
40	1012-040-00	19.6
50	1012-050-00	31.0
60	1012-060-00	45.6
80	1012-080-00	79.2

Ordering example:

For a shaft support rail with shaft of 40 mm diameter, 2400 mm length, the ordering data is **1012-040-00 / 2400 mm**.

Only available with ready-mounted shaft.

Dimensions

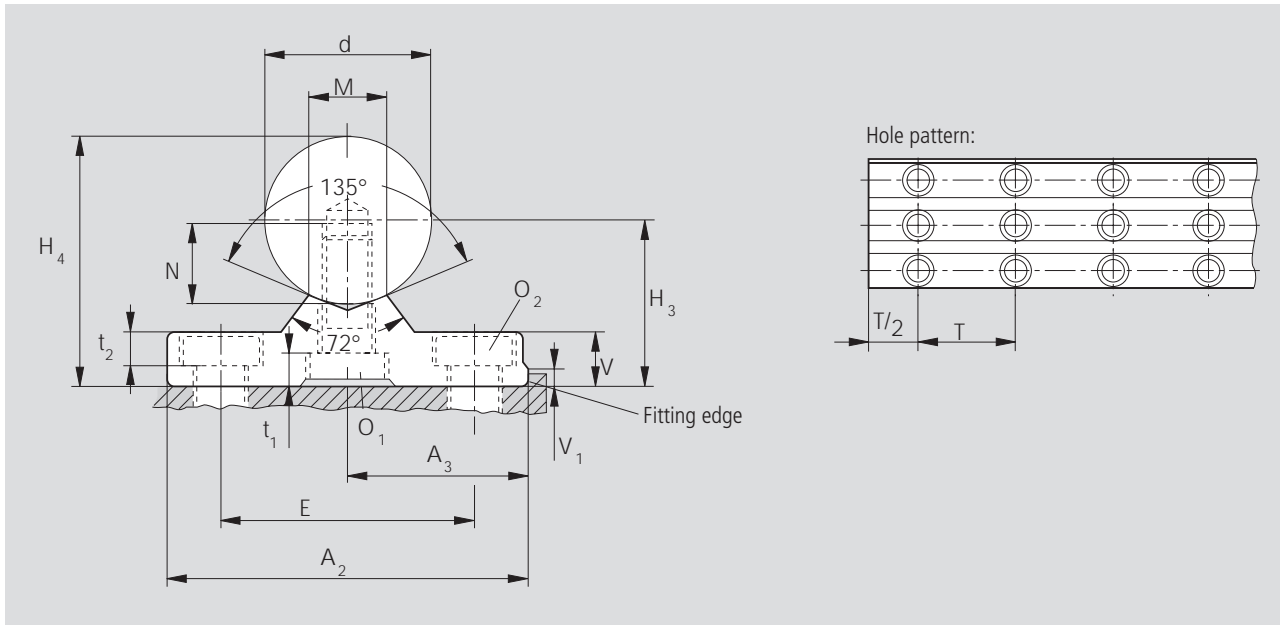

Ø d	Dimensions (mm)														Tolerances within one grade (µm)	
	A ₂	A ₃	H ₃ ¹⁾	H ₄	V	V ₁	M -0.5	E	O ₁ DIN 6912-8.8	t ₁	N	O ₂ DIN 7984-8.8	t ₂	T	H ₃ ²⁾	Shaft h ₆ H ₄ ³⁾
30	68	34±0.02	33	48	11	6	13	46	M10x25	9	17	M10	6.8	60	20 ⁴⁾	29
40	85	42.5±0.02	40	60	13	6	18	58	M12x30	10	21	M12	8.4	75	20 ⁴⁾	31
50	105	52.5±0.02	50	75	17	8	23	74	M16x40	10.8	28	M16	10.5	100	20 ⁴⁾	31
60	130	65±0.01	60	90	20	8	27	90	M20x40	16	32	M20	12.5	120	20	33
80	170	85±0.01	80	120	26	10	37	120	M24x60	16	40	M24	16	150	20	33

1) Tolerance ±0.02; delivered graded by height to 20 µm.

2) Measured (when screwed down) with gauging shaft of nominal diameter d and length approx. 50 mm.

3) Including shaft tolerance, measured when screwed to base mounting surface (statistically determined).

4) Lengths up to 3000 mm with a parallelism of 10 µm on request.

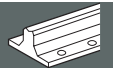

STAR – Shaft Support Blocks

In linear motion systems with closed Linear Sets the guiding shafts are mounted at their ends. Precision Shaft Support Blocks have been developed specifically for this purpose.

Advantages

- Considerable cost benefits as compared with customer-built designs
- High rigidity
- High dimensional accuracy makes elements interchangeable



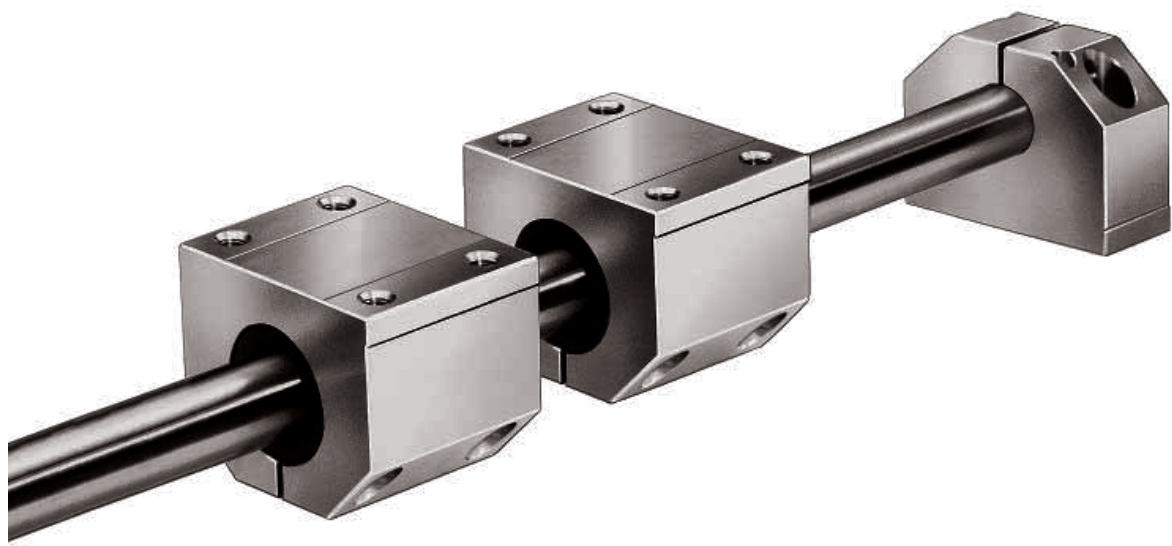

STAR – Shaft Support Blocks

Shaft Support Blocks, 1055-

For use with Linear Bushings or Linear Sets incorporating Standard or Super Linear Bushings, closed or adjustable types, and with Linear Sets incorporating Segmental Linear Bushings.

Material

- Spheroidal graphite cast iron

Ordering data



Shaft Ø d (mm)	Part numbers	Mass (kg)
8	1055-008-00	0.03
12	1055-012-00	0.06
16	1055-016-00	0.12
20	1055-020-00	0.22
25	1055-025-00	0.37
30	1055-030-00	0.55
40	1055-040-00	0.97
50	1055-050-00	1.90
60	1055-060-00	3.60
80	1055-080-00	7.30

Dimensions

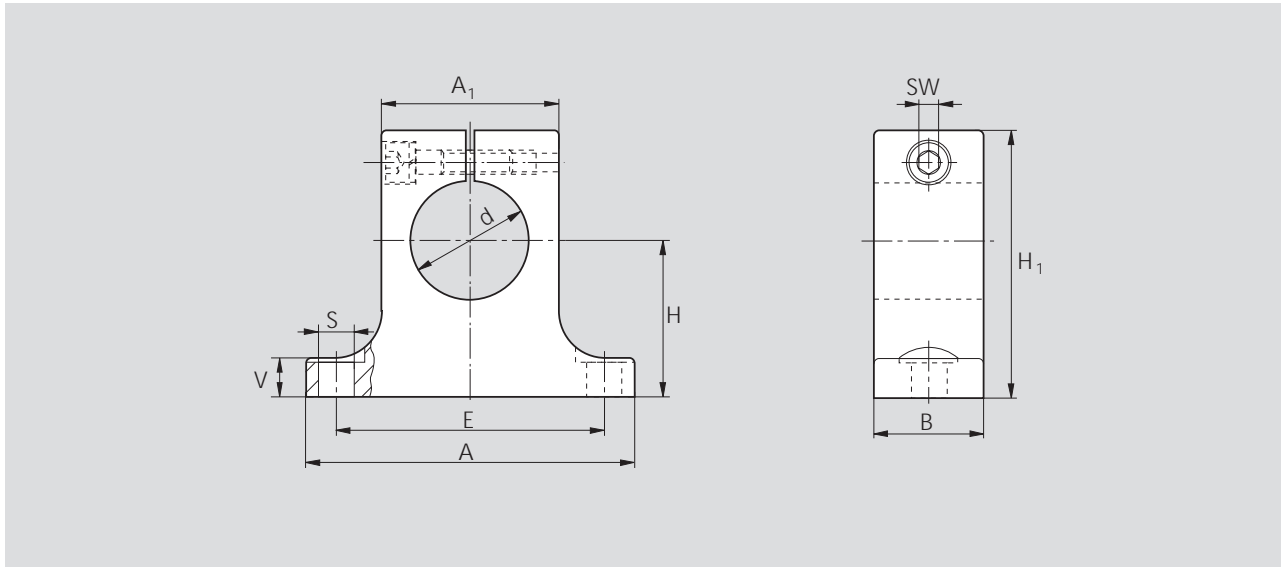

Dimensions (mm)										
$\varnothing d$	d_{H8}	$H^{1)}$	$H_1^{2)}$	$A^{2)}$	$A_1^{2)}$	$B^{2)}$	E	$S^{3)}$	$V^{2)}$	SW
8	8	15±0.010	27	32	16	10	25±0.15	4.5	5	2.5
12	12	20±0.010	35	42	20	12	32±0.15	5.5	5.5	3
16	16	25±0.010	42	50	26	16	40±0.15	5.5	6.5	3
20	20	30±0.010	50	60	32	20	45±0.15	5.5	8	3
25	25	35±0.010	58	74	38	25	60±0.15	6.6	9	4
30	30	40±0.010	68	84	45	28	68±0.20	9.0	10	5
40	40	50±0.010	86	108	56	32	86±0.20	11.0	12	6
50	50	60±0.015	100	130	80	40	108±0.20	11.0	14	6
60	60	75±0.015	124	160	100	48	132±0.25	13.5	15	8
80	80	100±0.015	160	200	130	60	170±0.50	17.5	22	10

1) Relative to shaft nominal dimension d .

2) Tolerance to DIN 1685 – GTB 15.

3) Mounting screws to ISO 4762-8.8.



STAR – Shaft Support Blocks

Shaft Support Blocks, 1057-

For use with Linear Bushings or Linear Sets.

Structural Design

- Rigid mounting of shaft due to extra-wide construction
- Centering bores provided for additional pins
- With fitting edge (available as of the year 2000)
- Sizes 20 and 25 also for ALU-STAR Profile Systems (available as of the year 2000)

Material

- Aluminum

Ordering data



Shaft Ø d (mm)	Part numbers	Mass (kg)
10	1057-010-00	0.05
12	1057-012-00	0.06
16	1057-016-00	0.11
20	1057-020-00	0.18
25	1057-025-00	0.35
30	1057-030-00	0.48
40	1057-040-00	0.90
50	1057-050-00	1.50
60	1057-060-00	3.00

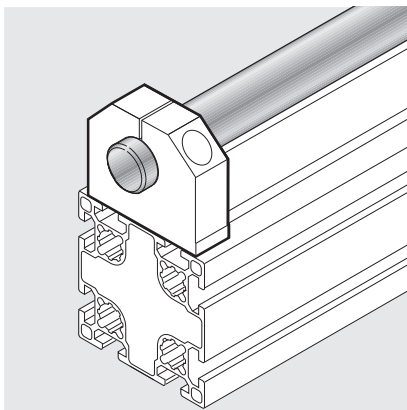

For ALU-STAR Profile Systems

Shaft Ø d (mm)	Part numbers	Mass (kg)	Combinable with ALU-STAR Profile	
			profile width (mm)	groove spacing (mm)
20	1057-820-00	0.18	80	40
25	1057-825-00	0.35	100	50

Dimensions

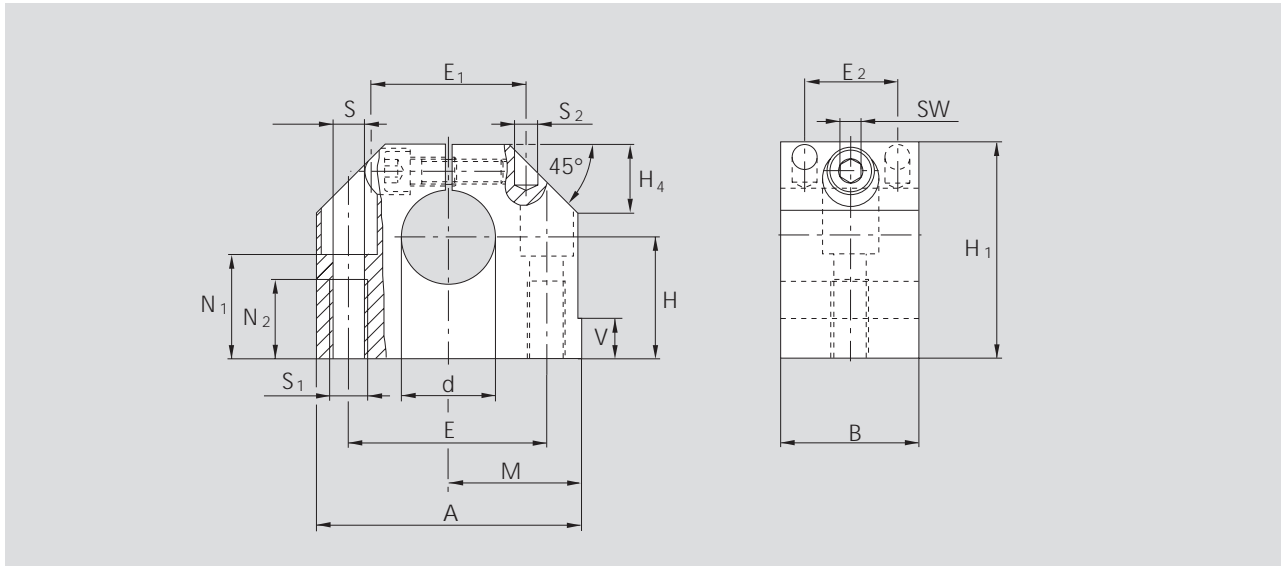

Dimensions (mm)																	
Ø d	d	H ¹⁾	H ₁	M ¹⁾	A	B	E	E ₁ ³⁾	E ₂ ³⁾	S ²⁾	S ₁	S ₂ ³⁾	N ₁	N ₂	V	SW	H ₄
	H8	±0.01		±0.01													
10	10	18	31	20	40	20	27±0.15	17	13	5.3	M6	4	14	13	5	3	10
12	12	20	35	21.5	43	20	30±0.15	20	13	5.3	M6	4	16.5	13	5	3	10
16	16	25	42	26.5	53	24	38±0.15	26	16	6.6	M8	5	21	18	5	4	13
20	20	30	51	30	60	30	42±0.15	30	20	8.4	M10	6	25	22	5	5	16
25	25	35	61	39	78	38	56±0.15	40	25	10.5	M12	8	30	26	6.5	6	20
30	30	40	70	43.5	87	40	64±0.15	45	26	10.5	M12	8	34	26	8	6	22
40	40	50	88	54	108	48	82±0.15	65	32	13.5	M16	10	44	34	10	8	28
50	50	60	105	66	132	58	100±0.20	70	36	17.5	M20	12	49	42	12	10	37
60	60	75	130	82	164	74	124±0.20	90	46	22	M27	16	59	42	13	14	42

¹⁾ Relative to shaft nominal dimension d.

²⁾ Mounting screws to ISO 4762-8.8.

³⁾ Two centering holes for pins.

For ALU-STAR Profile Systems

Dimensions (mm)																	
Ø d	d	H ⁴⁾	H ₁	M ⁴⁾	A	B	E	E ₁	E ₂	S ⁵⁾	S ₁	S ₂	N ₁	N ₂	V	SW	H ₄
	H8	±0.01		±0.01													
20	20	30	51	30	60	30	40±0.15	–	–	6.6	–	–	27	–	5	5	16
25	25	35	61	39	78	38	50±0.15	–	–	9.0	–	–	32	–	6.5	6	20

⁴⁾ Relative to shaft nominal dimension d.

⁵⁾ Mounting screws to ISO 4762-8.8.



STAR – Shaft Support Blocks

Shaft Support Blocks, 1056- with flange

For use with Linear Bushings or Linear Sets, closed or adjustable type.

Flange-On Shaft Support Blocks – ready-to-mount shaft support elements

This element is the latest addition to our range of Flanged Linear Sets and has been developed for use with Precision Steel Shafts in cost-saving linear motion assemblies.

Material

- Lamellar graphite cast iron

Ordering data



Shaft Ø d (mm)	Part numbers	Mass (kg)
12	1056-012-00	0.15
16	1056-016-00	0.21
20	1056-020-00	0.28
25	1056-025-00	0.41
30	1056-030-00	0.75
40	1056-040-00	1.65
50	1056-050-00	2.60

Dimensions

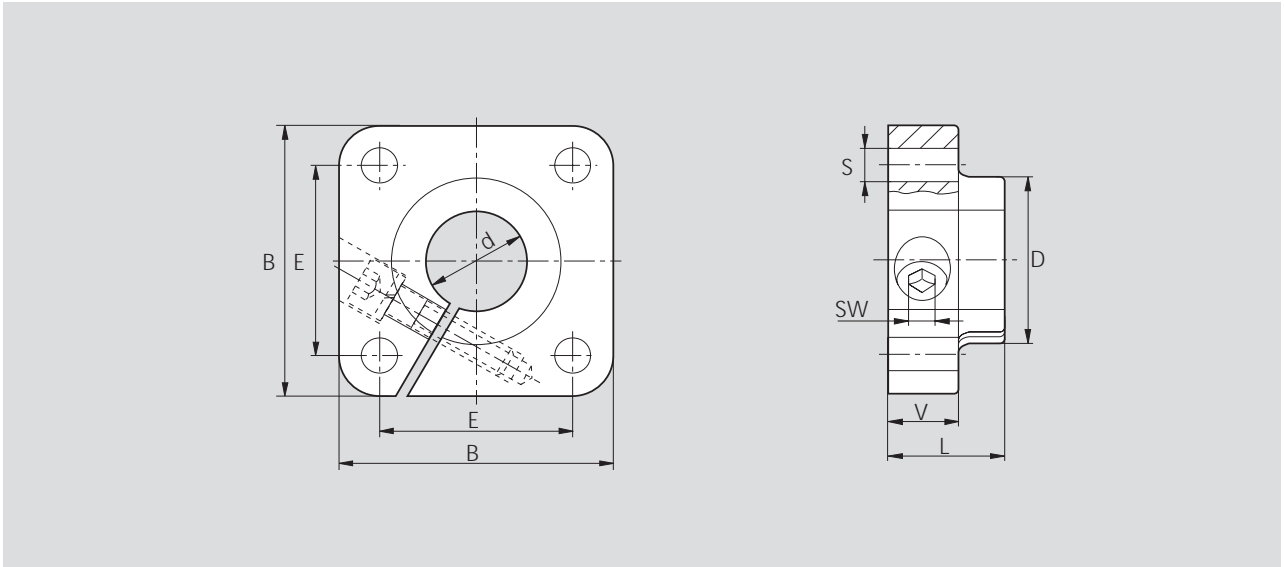

Dimensions (mm)								
$\varnothing d$	d H7	B ¹⁾	L ¹⁾	D ¹⁾	E	S H13	V ¹⁾	SW
12	12	42	20	23.5	30±0.12	5.5	12	3
16	16	50	20	27.5	35±0.12	5.5	12	3
20	20	54	23	33.5	38±0.15	6.6	14	4
25	25	60	25	42.0	42±0.15	6.6	16	5
30	30	76	30	49.5	54±0.25	9.0	19	6
40	40	96	40	65.0	68±0.25	11.0	26	8
50	50	106	50	75.0	75±0.25	11.0	36	8

¹⁾ Tolerance to DIN 1686 – GTB 15.



STAR – Shaft Support Blocks

Compact Shaft Support Blocks, 1058-

For use with Linear Bushings or Compact Linear Sets.

Compact Shaft Support Blocks help to build especially space-saving structures as they have been specifically tailored to match the small outer dimensions of Compact Linear Sets.

Material

- Aluminum

Ordering data



Shaft Ø d (mm)	Part numbers	Mass (kg)
12	1058-012-00	0.045
16	1058-016-00	0.065
20	1058-020-00	0.110
25	1058-025-00	0.170
30	1058-030-00	0.220
40	1058-040-00	0.470
50	1058-050-00	0.820

Dimensions

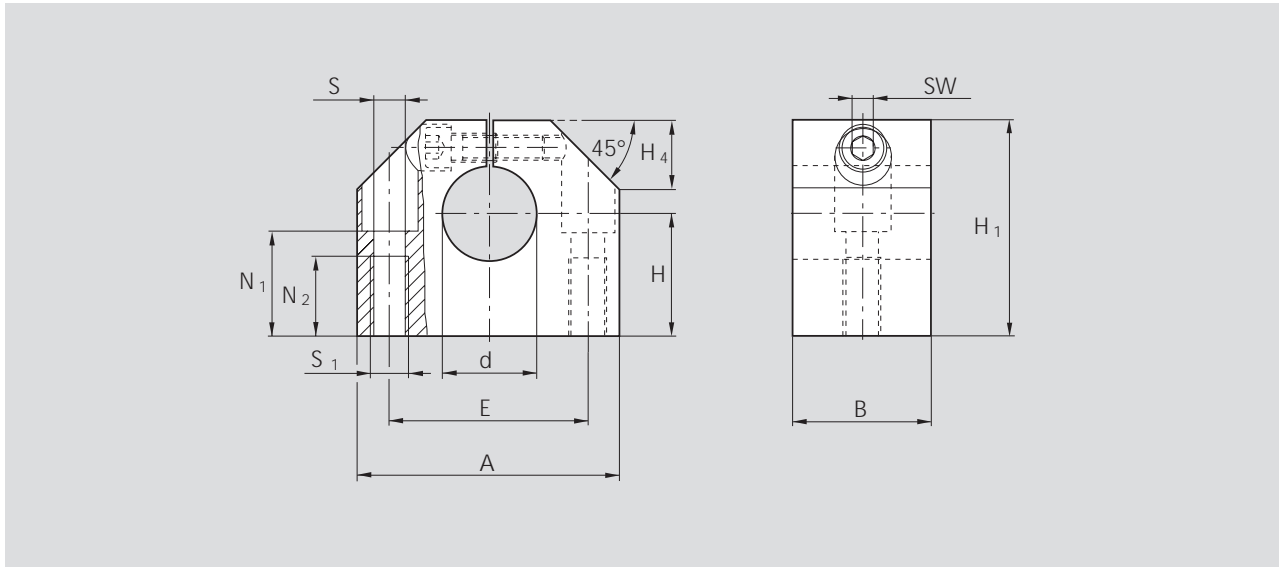

Dimensions (mm)												
$\emptyset d$	d H8	$H^{1)}$ ± 0.01	H_1	A	B	E ± 0.15	$S^{2)}$	S_1	N_1	N_2	H_4	SW
12	12	19	33	40	18	27	5.3	M6	16	13	11	3
16	16	22	38	45	20	32	5.3	M6	18	13	13	3
20	20	25	45	53	24	39	6.6	M8	22	18	15	4
25	25	31	54	62	28	44	8.4	M10	26	22	17	5
30	30	34	60	67	30	49	8.4	M10	29	22	19	5
40	40	42	76	87	40	66	10.5	M12	38	26	24	6
50	50	50	92	103	50	80	13.5	M16	46	34	30	8

¹⁾ Relative to shaft nominal dimension d .

²⁾ Mounting screws to ISO 4762-8.8.



Rexroth STAR

Worldwide availability and global service





Bosch Rexroth Linear Motion and Assembly Technologies division offers a complete line of STAR linear motion products...

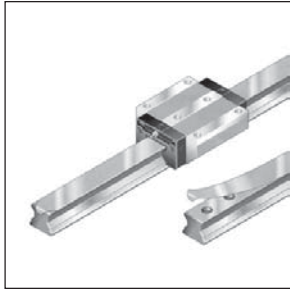

STAR Ball Rail® Systems
RA 82 201

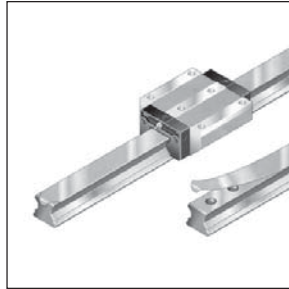

STAR Roller Rails™
RA 82 301



Tychoway® Linear Roller Bearings
RA 99 001

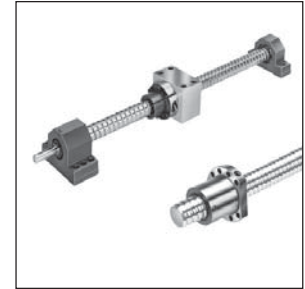

STAR Precision Ball Screws
RA 83 301

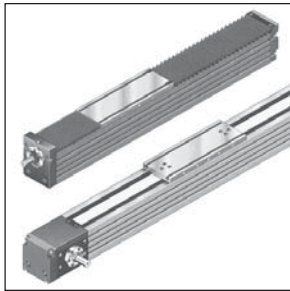

STAR Linear Modules
RA 82 402



STAR Compact Modules
RA 82 601

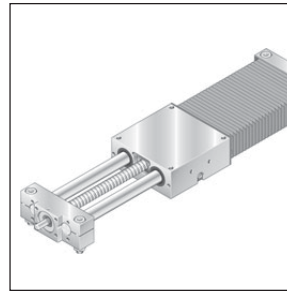

STAR Linear Motion Slides
RA 83 001

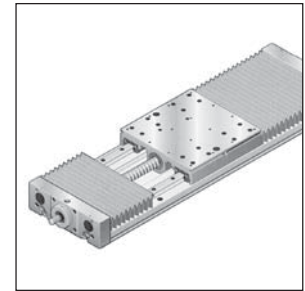

STAR Ball Rail® Tables
RA 82 501

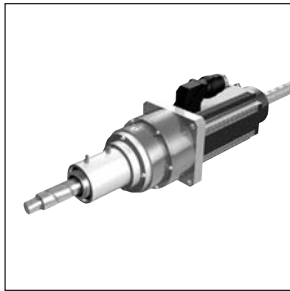

Hollow Shaft Motor
RA 83 315

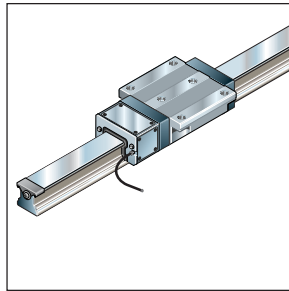

Integrated Measuring System
RA 82 350



Metric Linear Bushings
RA 83 100



Inch Linear Bushings
RA 99 110



STAR Ball Transfers
RA 82 910

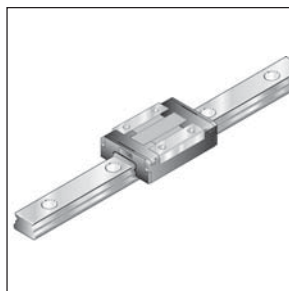

Miniature Ball Rail®
Systems
RA 82 210

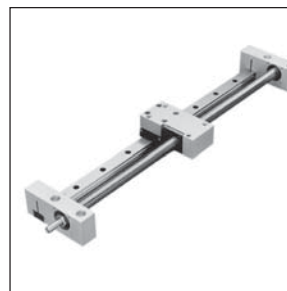

Mini Compact Slides
RA 99 007

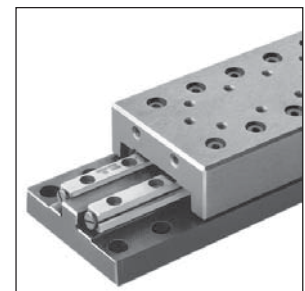

Tychoway® Roller Slides
RA 99 000

Rexroth
Bosch Group

Bosch Rexroth Corporation

Linear Motion and Assembly Technologies

14001 South Lakes Drive • Charlotte, NC 28273 • Telephone: (704)583-4338 • (800)438-5983

Telefax: (704)583-0523 • <http://boschrexroth-us.com> • E-mail: info.chr@boschrexroth-us.com

STAR, Ball Rail, and  are registered trademarks of Deutsche Star GmbH, Schweinfurt, Germany

Copyright
© BOSCH REXROTH 2001
All rights reserved.

Supersedes all previous issues.
The illustrations and drawings in the catalog show principles of design or operation and are for reference only, subject to alteration without notice.

This catalog or any part thereof may not be reproduced without our written permission.